

No. VA009-A-P-SD-2.0

TITLE	TO252-9S-A-PKG Dimensions
No.	VA009-A-P-SD-2.0
ANGLE	
UNIT	mm
<b>ABLIC Inc.</b>	

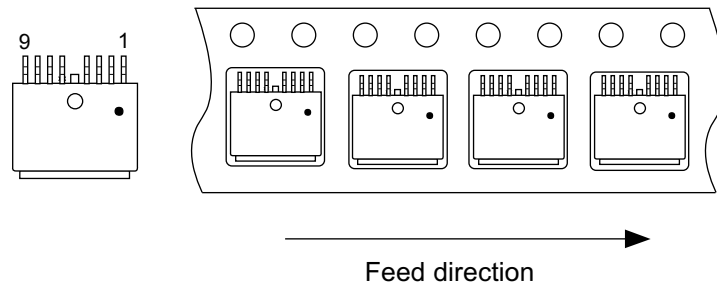
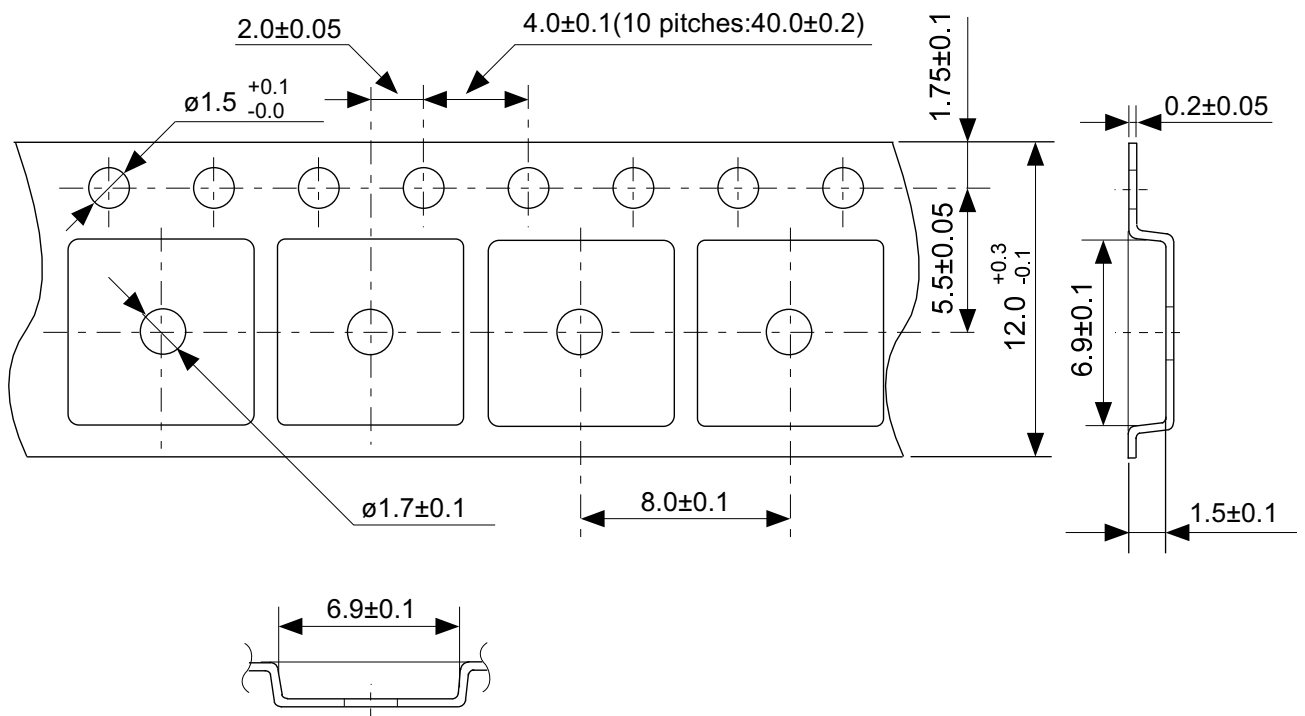

No. VA009-A-C-SD-1.0

TITLE	TO252-9S-A-Carrier Tape
No.	VA009-A-C-SD-1.0
ANGLE	
UNIT	mm
<b>ABLIC Inc.</b>	

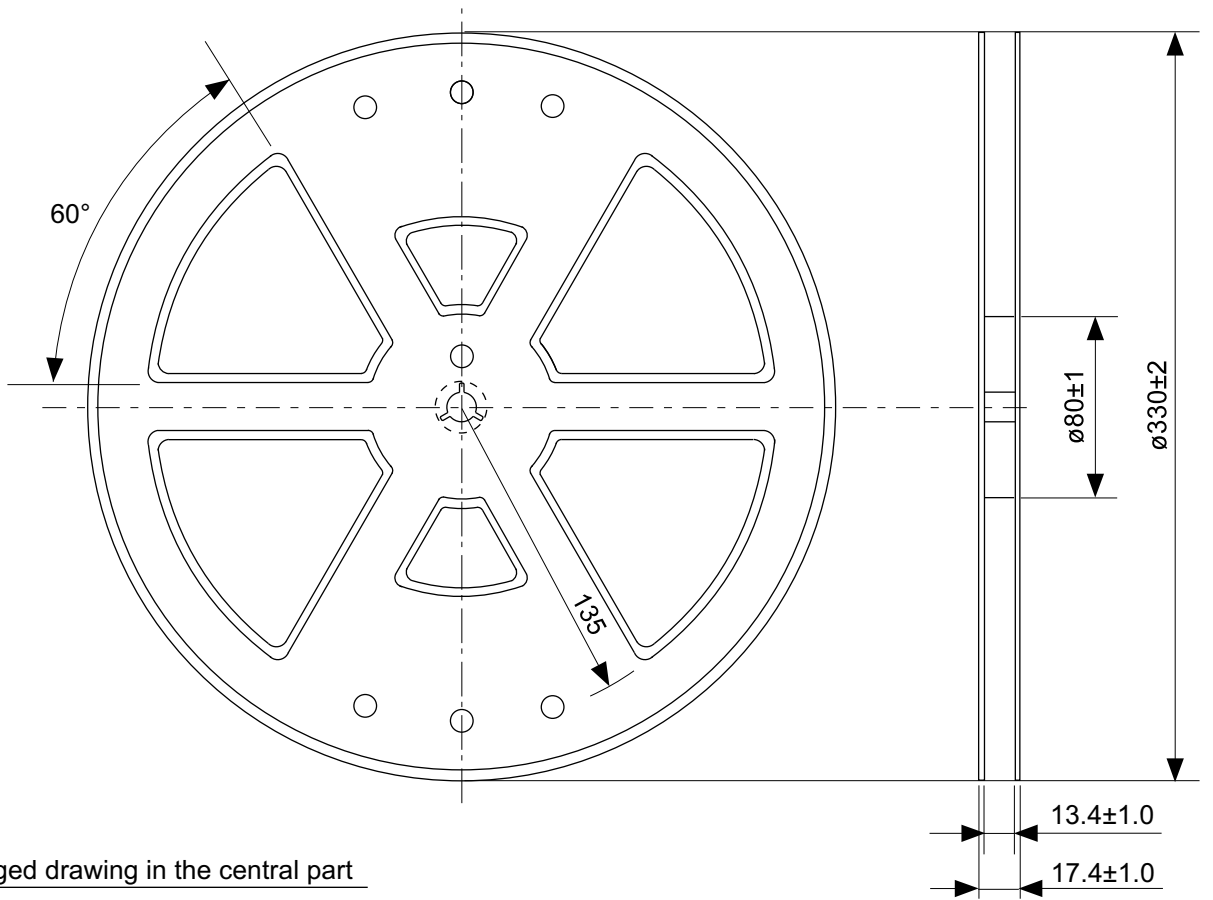

Enlarged drawing in the central part

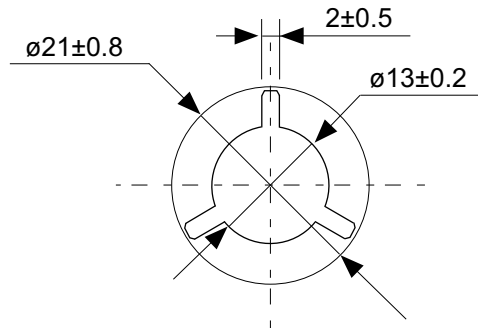

No. VA009-A-R-SD-1.0

TITLE	TO252-9S-A-Reel		
No.	VA009-A-R-SD-1.0		
ANGLE		QTY.	4,000
UNIT	mm		
<b>ABLIC Inc.</b>			

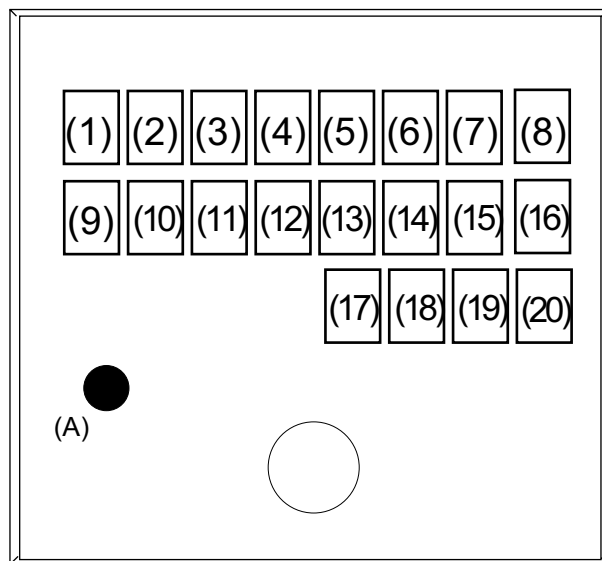

(1) to (12) : Product code

(13) : Assembly code

(14) : Year of assembly

(15) : Month of assembly

(16) : Week of assembly

(17) to (20) : Lot No. code

(A) : 1-pin mark

No. VA009-A-M-SD-1.0

TITLE	TO252-9S-A-Markings		
No.	VA009-A-M-SD-1.0		
ANGLE			
UNIT		TYPE	LASER
<b>ABLIC Inc.</b>			

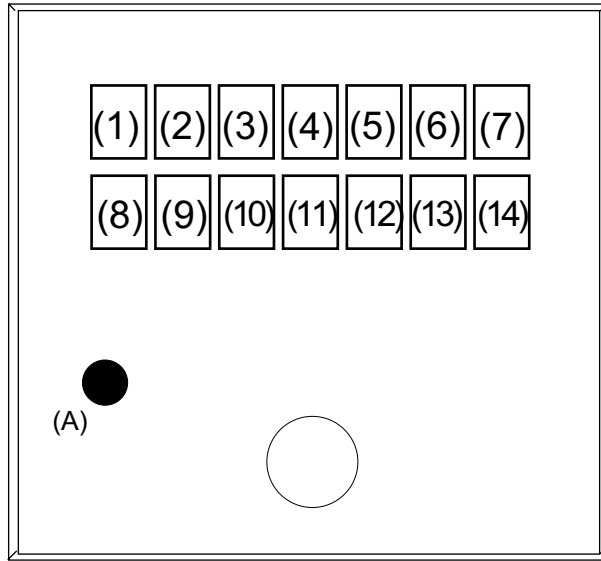

- (1) to (6) : Product code
- (7) : Assembly code
- (8) : Year of assembly
- (9) : Month of assembly
- (10) : Week of assembly
- (11) to (14) : Lot No. code
- (A) : 1-pin mark

No. VA009-A-M-S1-1.0

TITLE	TO252-9S-A-Markings		
No.	VA009-A-M-S1-1.0		
ANGLE			
UNIT		TYPE	LASER
<b>ABLIC Inc.</b>			

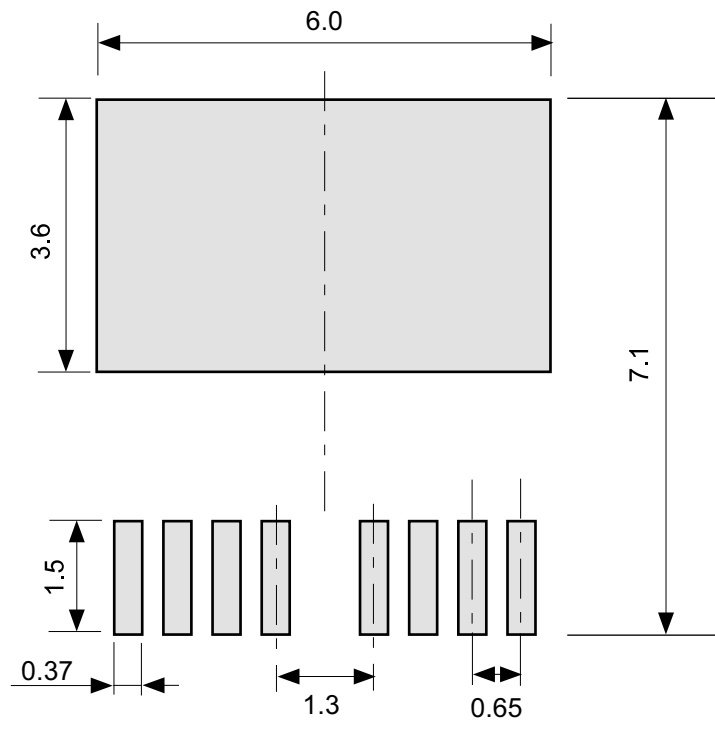

No. VA009-A-L-SD-1.0

TITLE	TO252-9S-A -Land Recommendation
No.	VA009-A-L-SD-1.0
ANGLE	
UNIT	mm
<b>ABLIC Inc.</b>	