

No. NP004-A-P-SD-2.0

TITLE	SC82AB-A-PKG Dimensions
No.	NP004-A-P-SD-2.0
ANGLE	
UNIT	mm
ABLIC Inc.	

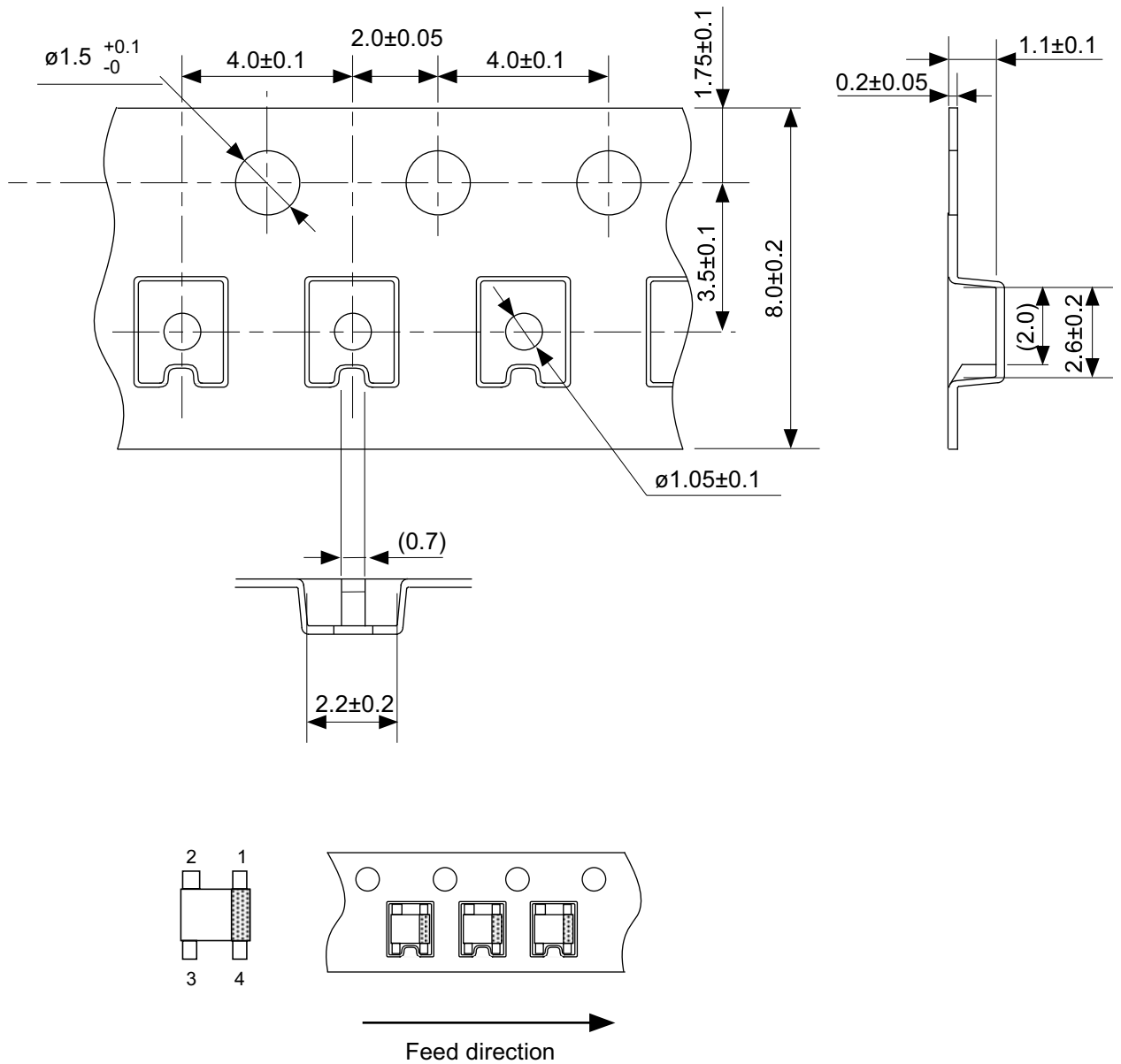

No. NP004-A-C-SD-3.0

TITLE	SC82AB-A-Carrier Tape
No.	NP004-A-C-SD-3.0
ANGLE	
UNIT	mm
ABLIC Inc.	

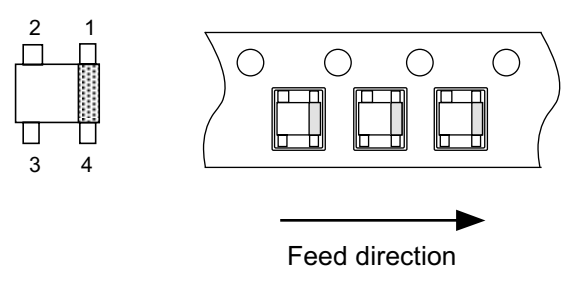
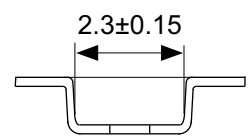
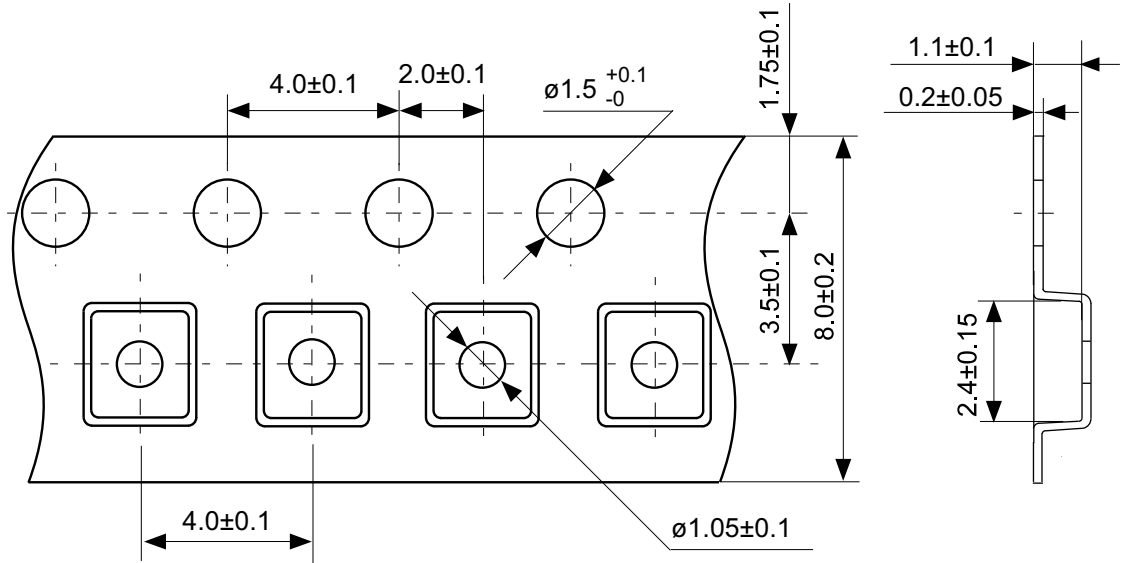

No. NP004-A-C-S1-2.0

TITLE	SC82AB-A-Carrier Tape
No.	NP004-A-C-S1-2.0
ANGLE	
UNIT	mm
ABLIC Inc.	

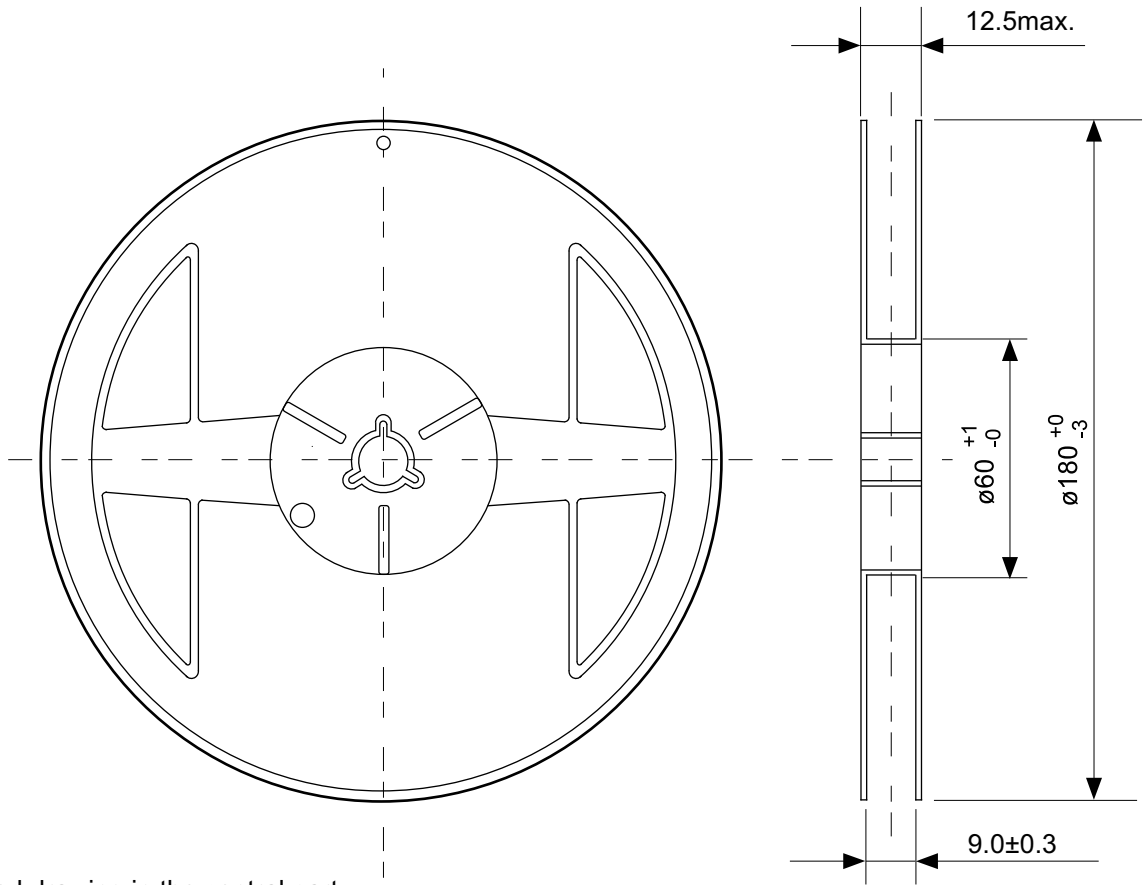

Enlarged drawing in the central part

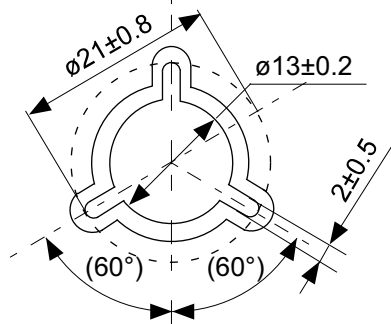

No. NP004-A-R-SD-1.1

TITLE	SC82AB-A-Reel		
No.	NP004-A-R-SD-1.1		
ANGLE		QTY.	3,000
UNIT	mm		
ABLIC Inc.			

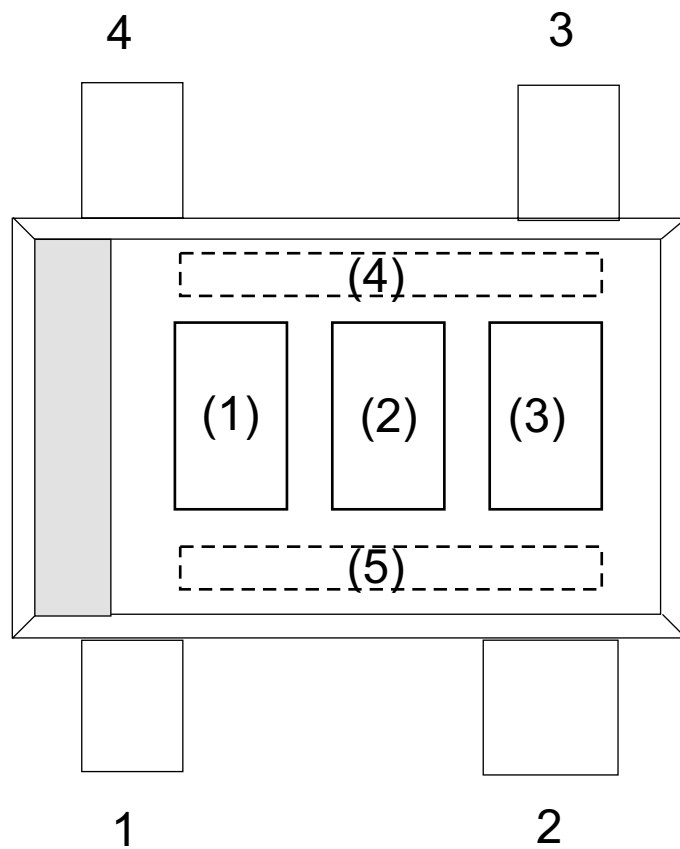

(1) to (3) : Product code

(4) : Year of assembly (Dot)

(5) : Month of assembly (Dot)

No. NP004-A-M-SD-1.1

TITLE	SC82AB-A-Markings		
No.	NP004-A-M-SD-1.1		
ANGLE			
UNIT		TYPE	LASER
ABLIC Inc.			

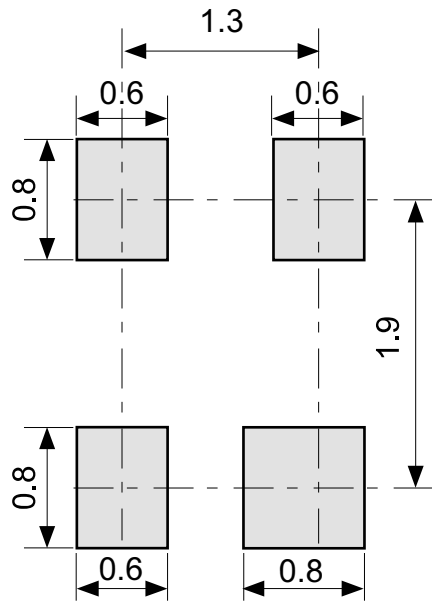

No. NP004-A-L-SD-1.1

TITLE	SC82AB-A -Land Recommendation
No.	NP004-A-L-SD-1.1
ANGLE	
UNIT	mm
ABLIC Inc.	