

No. FU008-A-P-SD-1.1

TITLE	HSOP8Q-A-PKG Dimensions
No.	FU008-A-P-SD-1.1
ANGLE	
UNIT	mm
ABLIC Inc.	

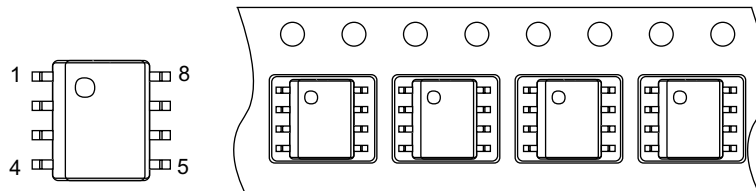
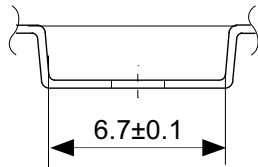
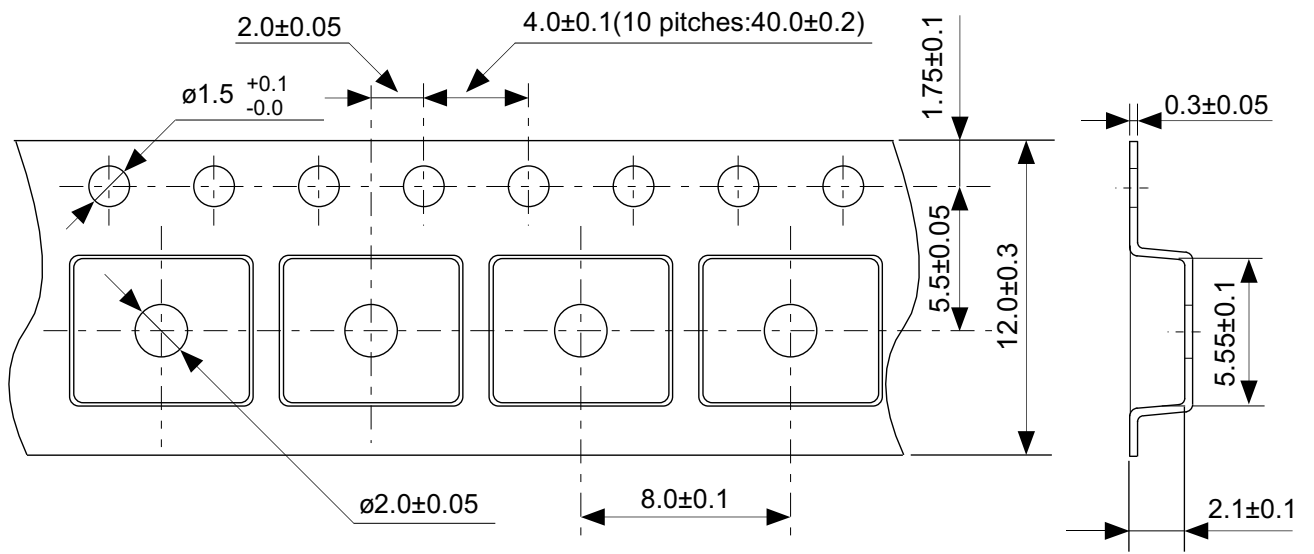

Feed direction →

No. FU008-A-C-SD-1.0

TITLE	HSOP8Q-A-Carrier Tape
No.	FU008-A-C-SD-1.0
ANGLE	
UNIT	mm
ABLIC Inc.	

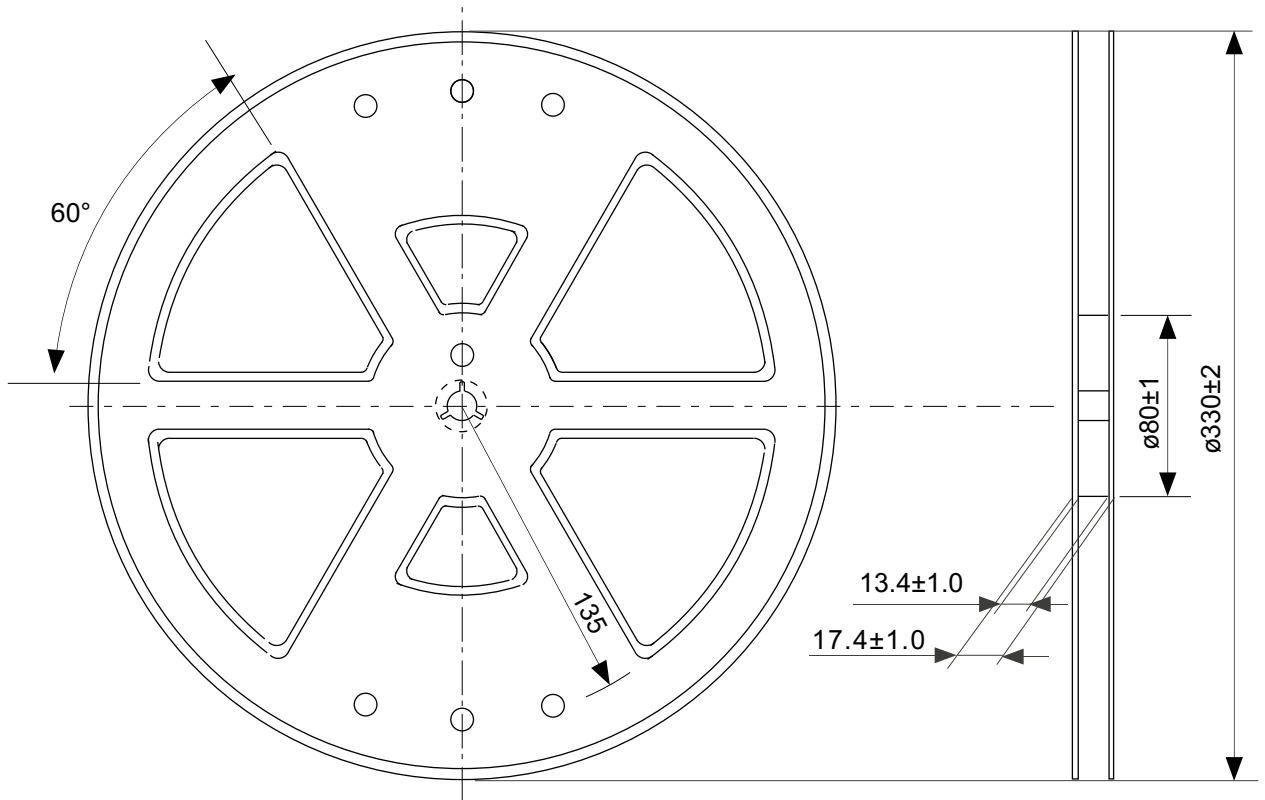

Enlarged drawing in the central part

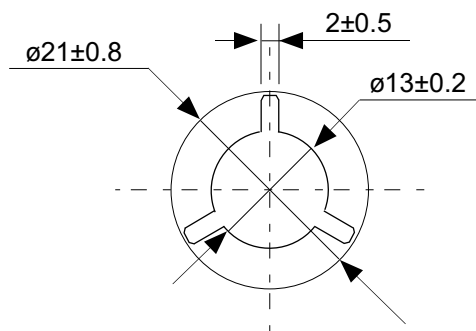

No. FU008-A-R-SD-1.1

TITLE	HSOP8Q-A-Reel		
No.	FU008-A-R-SD-1.1		
ANGLE		QTY.	4,000
UNIT	mm		
ABLIC Inc.			

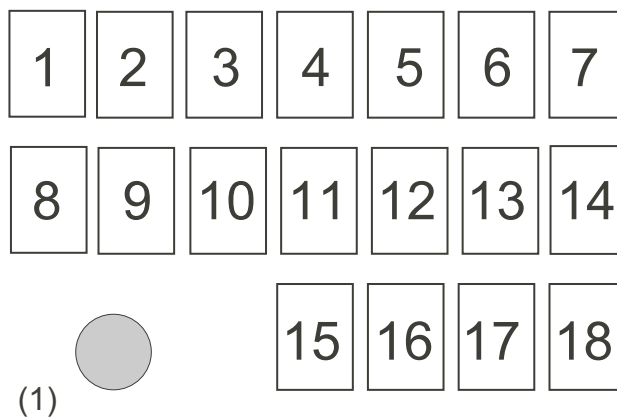

1 to 11 : Product code

12 : Assembly code

13 : Year of assembly

14 : Month of assembly

15 to 18 : Lot No. code

(1) : 1-pin mark

No. FU008-A-M-SD-1.0

TITLE	HSOP8Q-A-Markings		
No.	FU008-A-M-SD-1.0		
ANGLE			
UNIT		TYPE	LASER
ABLIC Inc.			

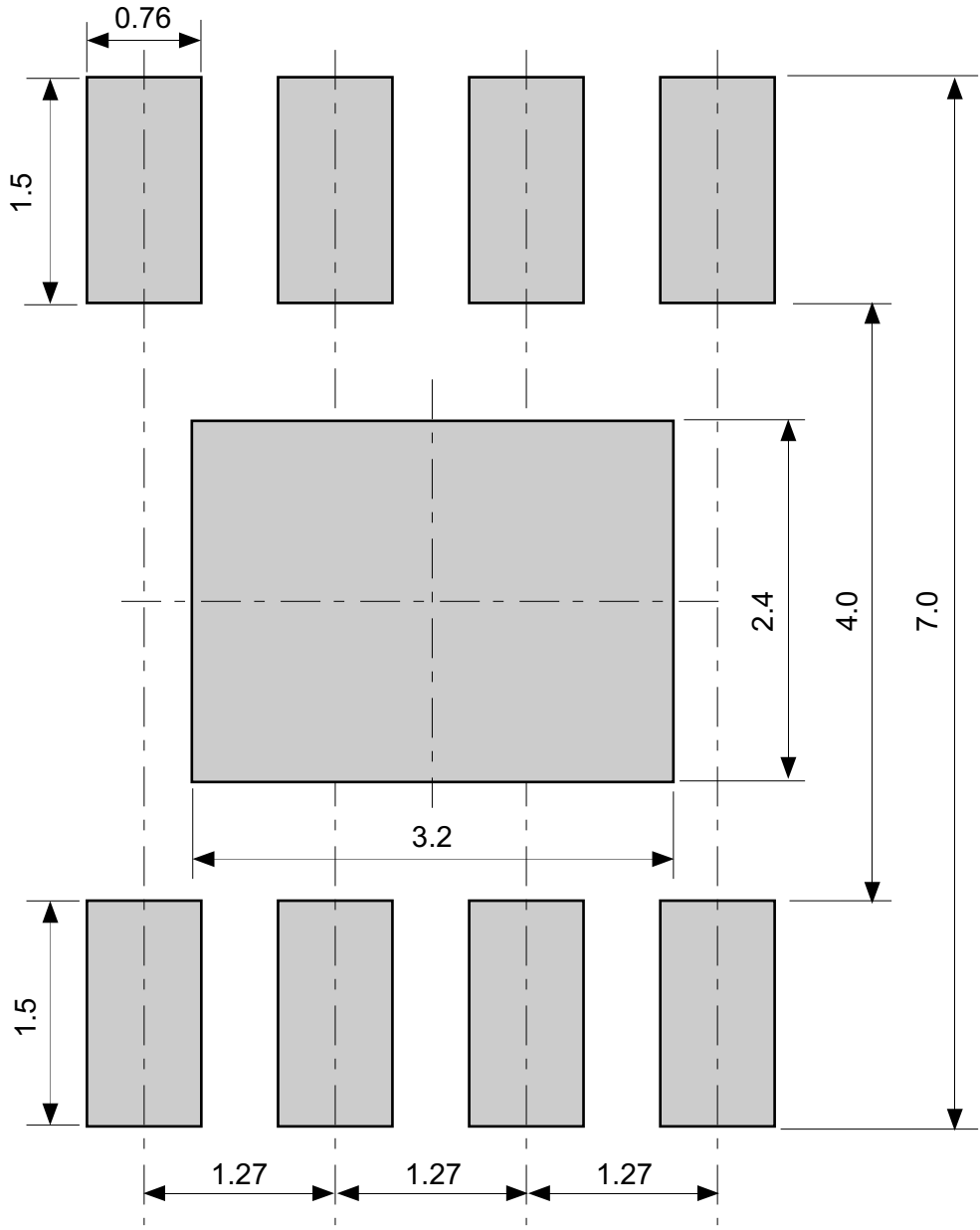

No. FU008-A-L-SD-1.0

TITLE	HSOP8Q-A -Land Recommendation
No.	FU008-A-L-SD-1.0
ANGLE	
UNIT	mm
ABLIC Inc.	