

No. FJ008-Z-P-SD-2.1

| | |
|-------------------|------------------------|
| TITLE | SOP8J-Z-PKG Dimensions |
| No. | FJ008-Z-P-SD-2.1 |
| ANGLE | |
| UNIT | mm |
| ABLIC Inc. | |

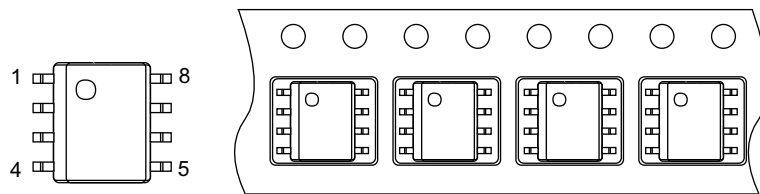
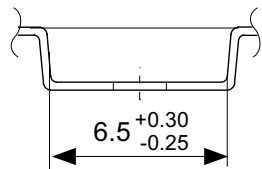
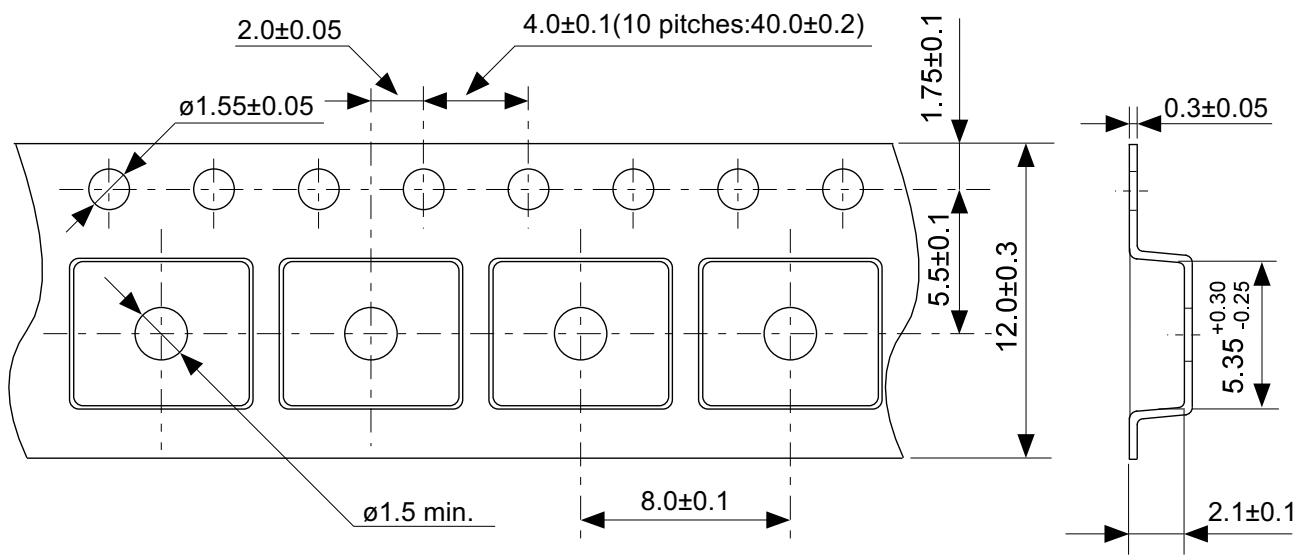

→
Feed direction

No. FJ008-Z-C-SD-1.0

| | |
|-------------------|----------------------|
| TITLE | SOP8J-Z-Carrier Tape |
| No. | FJ008-Z-C-SD-1.0 |
| ANGLE | |
| UNIT | mm |
| | |
| ABLIC Inc. | |

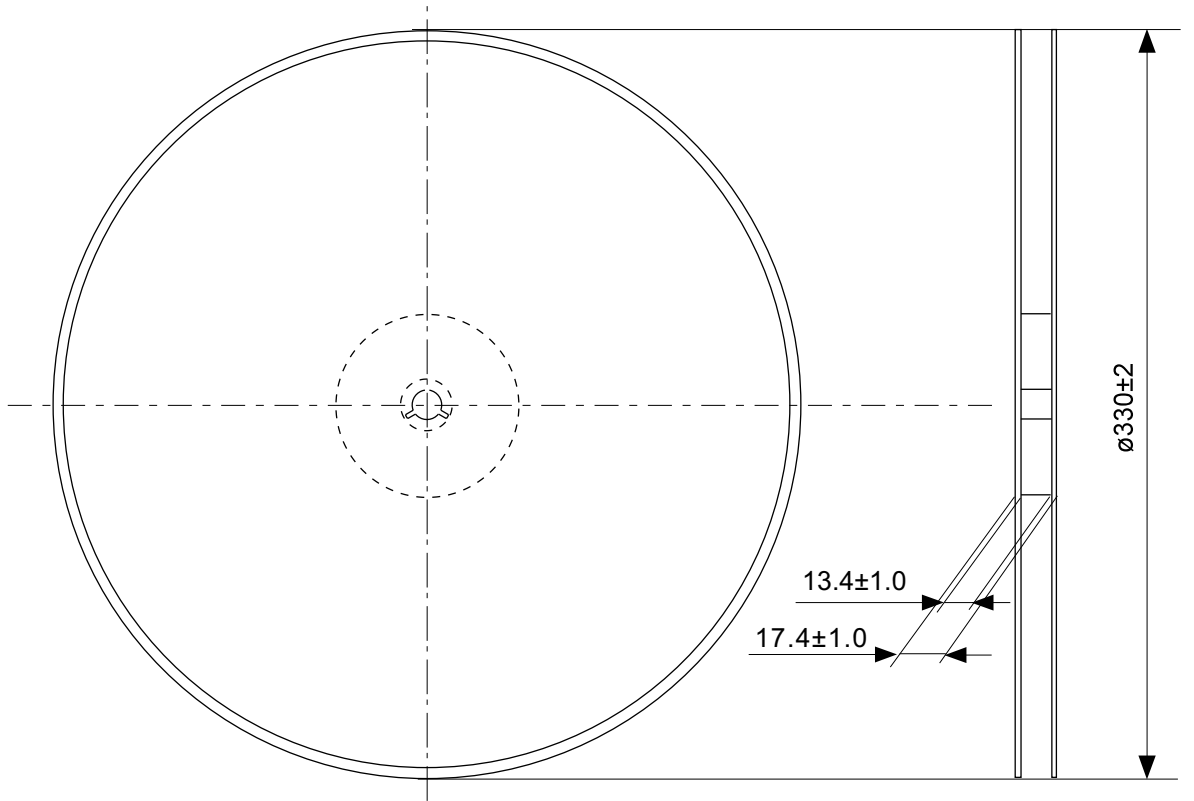

Enlarged drawing in the central part

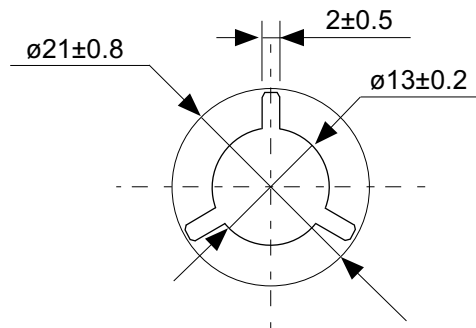

No. FJ008-Z-R-SD-2.0

| | | | |
|-------------------|------------------|------|-------|
| TITLE | SOP8J-Z-Reel | | |
| No. | FJ008-Z-R-SD-2.0 | | |
| ANGLE | | QTY. | 4,000 |
| UNIT | mm | | |
| | | | |
| ABLIC Inc. | | | |

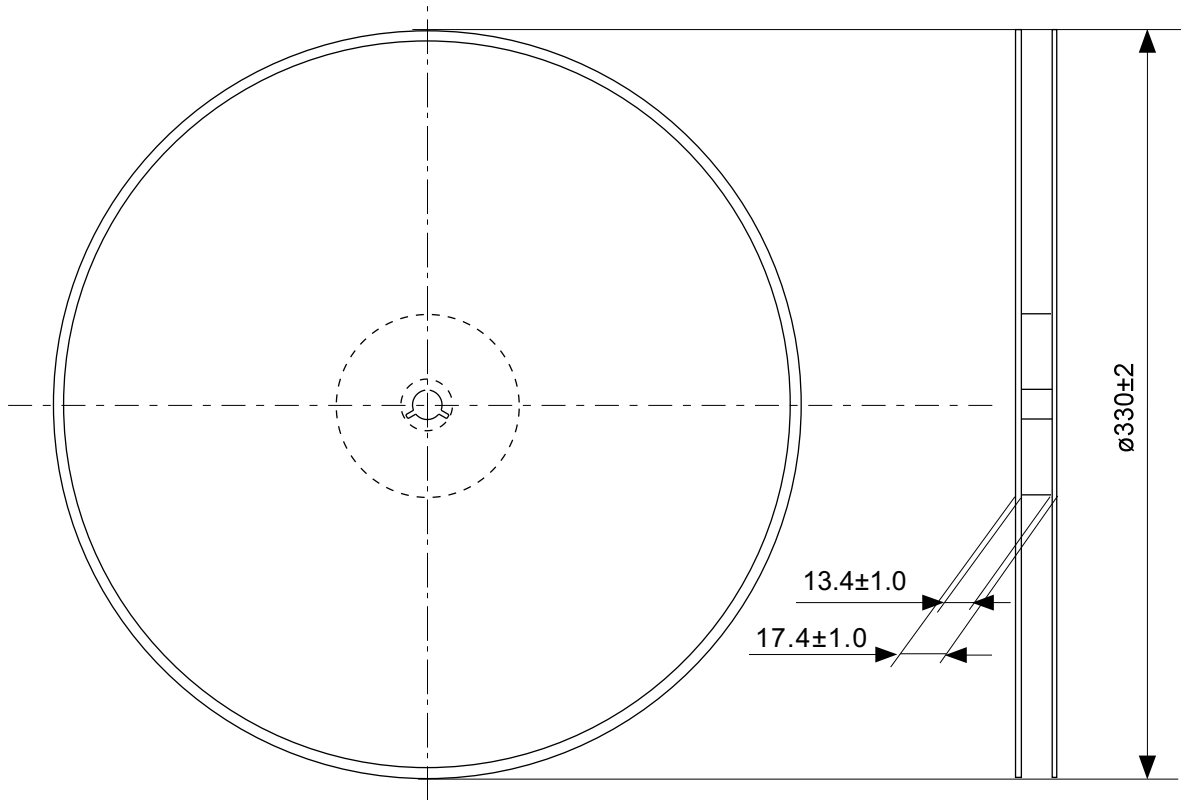

Enlarged drawing in the central part

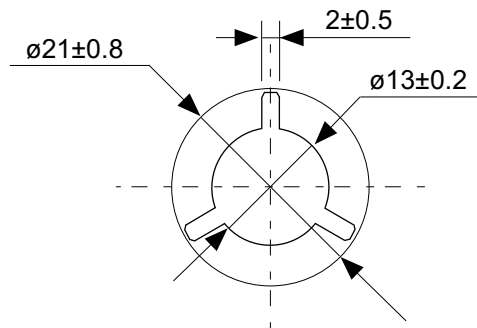

No. FJ008-Z-R-S1-2.0

| | | | |
|-------------------|------------------|------|-------|
| TITLE | SOP8J-Z-Reel | | |
| No. | FJ008-Z-R-S1-2.0 | | |
| ANGLE | | QTY. | 2,000 |
| UNIT | mm | | |
| | | | |
| ABLIC Inc. | | | |

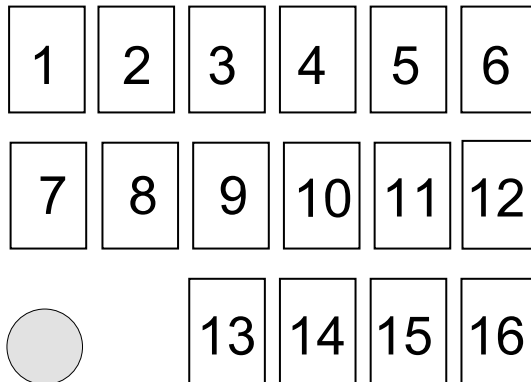

1 to 9 : Product code

10 : Assembly code

11 : Year of assembly

12 : Month of assembly

13 to 16 : Lot No. code

(1) : 1-pin mark

No. FJ008-A-M-SD-3.1

| | | | |
|-------------------|------------------|------|-------|
| TITLE | SOP8J-Z-Markings | | |
| No. | FJ008-A-M-SD-3.1 | | |
| ANGLE | | | |
| UNIT | | TYPE | LASER |
| | | | |
| ABLIC Inc. | | | |

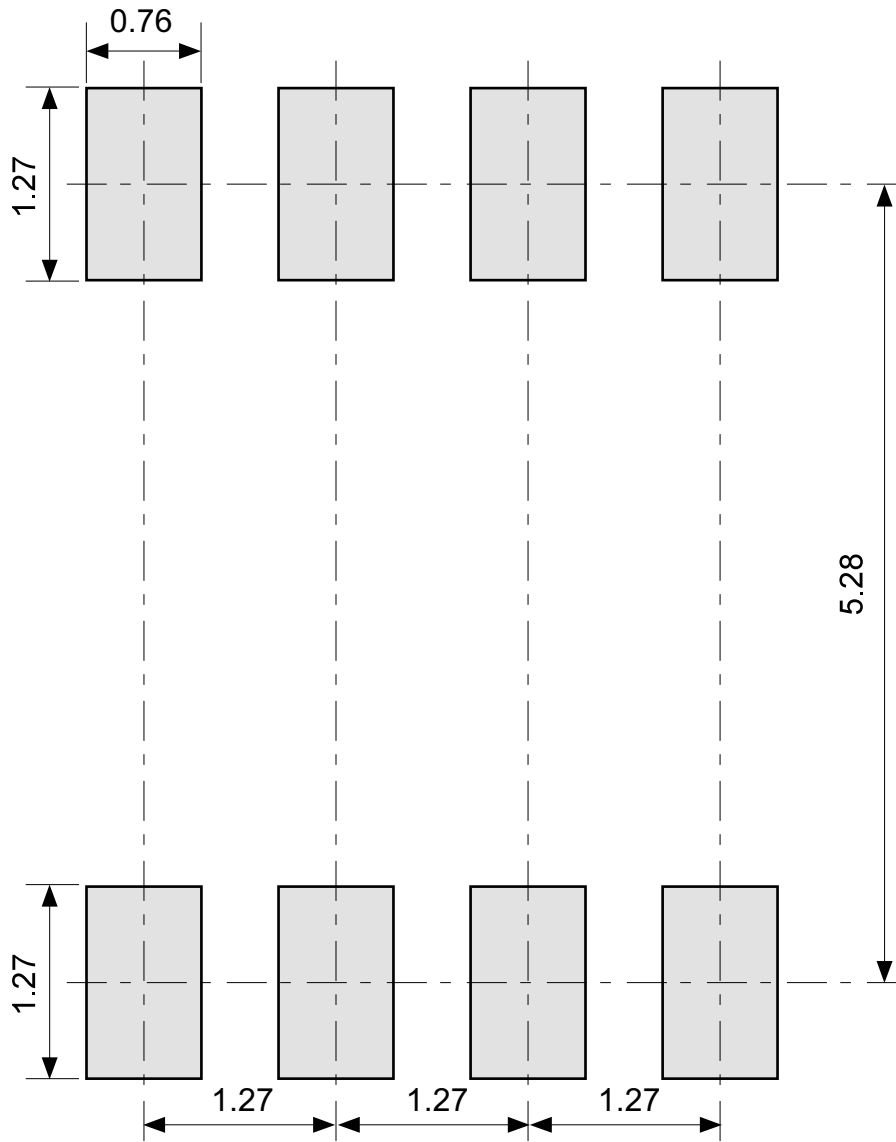

No. FJ008-A-L-SD-1.1

| | |
|-------------------|---------------------------------|
| TITLE | SOP8J-Z -Land Recommendation |
| No. | FJ008-A-L-SD-1.1 |
| ANGLE | |
| UNIT | mm |
| | |
| ABLIC Inc. | |