

This IC, developed using CMOS technology, is a high-accuracy voltage detector with the supply voltage divided output. The detection voltage and release voltage are fixed internally with an accuracy of $\pm 2.0\%$.

Apart from the power supply pin, the detection voltage input pin (SENSE pin) is also prepared, so the output is stable even if the SENSE pin voltage (V_{SENSE}) falls to 0 V. The SENSE pin also has a built-in reverse connection protection circuit that reduces current in the SENSE pin during a reverse connection.

The release signal can be delayed by setting a capacitor externally, and the release delay time accuracy is $\pm 20\%$ ($C_D = 3.3$ nF). The output form is Nch open-drain output.

The supply voltage divided output is prepared in this IC. The supply voltage divided output is a function that divides the V_{SENSE} into $V_{SENSE}/6$, $V_{SENSE}/8$, $V_{SENSE}/12$ or $V_{SENSE}/14$ and outputs the voltage. For example, this function makes it possible that the IC connects to a low voltage microcontroller A/D converter directly and the microcontroller monitors a battery voltage.

ABLIC Inc. offers FIT rate calculated based on actual customer usage conditions in order to support customer functional safety design.

For more information regarding our FIT rate calculation, contact our sales representatives.

Caution This product can be used in vehicle equipment and in-vehicle equipment. Before using the product for these purposes, it is imperative to contact our sales representatives.

■ Features

Detector block

- Detection voltage: 4.0 V to 10.0 V (0.05 V step)
- Detection voltage accuracy: $\pm 2.0\%$
- Hysteresis width selectable from "Available" / "Unavailable": "Available": 5.0%, 10.0%
"Unavailable": 0%
- Release delay time accuracy: $\pm 20\%$ ($C_D = 3.3$ nF)
- Output form: Nch open-drain output

Supply voltage divider block

- Output voltage: $V_{PMOUT} = V_{SENSE}/6$ (S-19117 Series L / M / N type)
 $V_{PMOUT} = V_{SENSE}/8$ (S-19117 Series P / Q / R type)
 $V_{PMOUT} = V_{SENSE}/12$ (S-19119 Series L / M / N type)
 $V_{PMOUT} = V_{SENSE}/14$ (S-19119 Series P / Q / R type)
- Output capacitor (C_{PM}): A ceramic capacitor can be used (0.1 μ F to 0.22 μ F).
- Built-in enable circuit: Ensures long battery life.

Overall

- Current consumption: During supply voltage divided output operates 1.15 μ A typ.
During supply voltage divided output stops 0.75 μ A typ.
- Built-in reverse connection protection circuit: Reduces current in the SENSE pin during a reverse connection.
- Operation voltage range: 3.0 V to 36.0 V
- Operation temperature range: $T_a = -40^\circ\text{C}$ to $+150^\circ\text{C}$
- Lead-free (Sn 100%), halogen-free
- AEC-Q100 in process*1

*1. Contact our sales representatives for details.

■ Applications

- Automotive battery voltage detection
- For automotive use (engine, transmission, suspension, ABS, related-devices for EV / HEV / PHEV, etc.)

■ Packages

- HTMSOP-8
- HSNT-8(2030)

■ **Block Diagrams**

1. **S-19117/19119 Series L / P type**

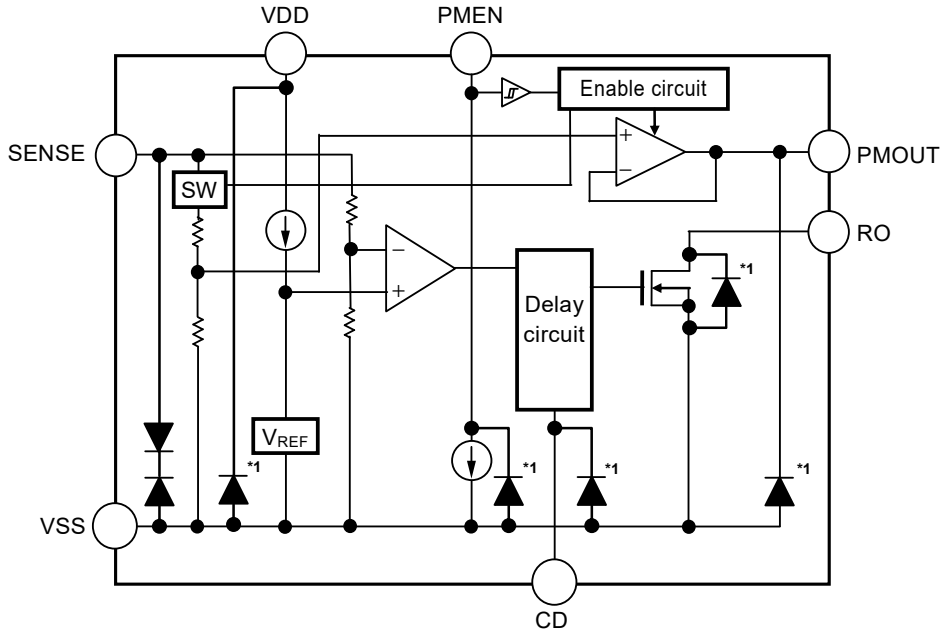

*1. Parasitic diode

Figure 1

1.1 **S-19117 Series**

Table 1

Product Type	Output Voltage of Supply Voltage Divider Block (V_{PMOUT})	Hysteresis Width	PMEN Pin Input Logic	RO Pin Output Form	RO Pin Output Logic
L type	$V_{SENSE}/6$	0%	Active "H"	Nch open-drain output	Active "L"
P type	$V_{SENSE}/8$	0%	Active "H"	Nch open-drain output	Active "L"

1.2 **S-19119 Series**

Table 2

Product Type	Output Voltage of Supply Voltage Divider Block (V_{PMOUT})	Hysteresis Width	PMEN Pin Input Logic	RO Pin Output Form	RO Pin Output Logic
L type	$V_{SENSE}/12$	0%	Active "H"	Nch open-drain output	Active "L"
P type	$V_{SENSE}/14$	0%	Active "H"	Nch open-drain output	Active "L"

2. S-19117/19119 Series M / N / Q / R type

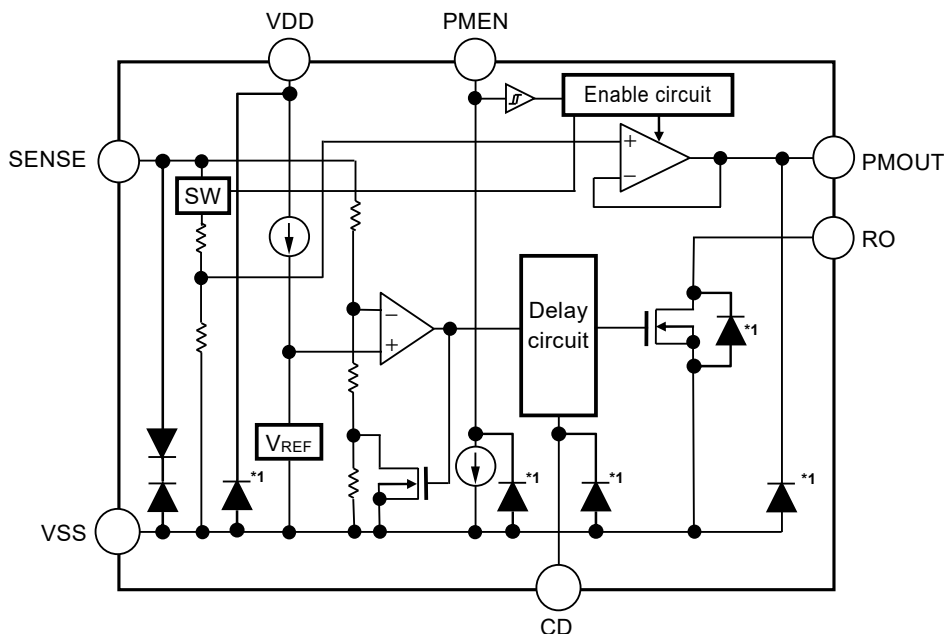

*1. Parasitic diode

Figure 2

2.1 S-19117 Series

Table 3

Product Type	Output Voltage of Supply Voltage Divider Block (V_{PMOUT})	Hysteresis Width	PMEN Pin Input Logic	RO Pin Output Form	RO Pin Output Logic
M type	$V_{SENSE}/6$	5.0%	Active "H"	Nch open-drain output	Active "L"
N type	$V_{SENSE}/6$	10.0%	Active "H"	Nch open-drain output	Active "L"
Q type	$V_{SENSE}/8$	5.0%	Active "H"	Nch open-drain output	Active "L"
R type	$V_{SENSE}/8$	10.0%	Active "H"	Nch open-drain output	Active "L"

2.2 S-19119 Series

Table 4

Product Type	Output Voltage of Supply Voltage Divider Block (V_{PMOUT})	Hysteresis Width	PMEN Pin Input Logic	RO Pin Output Form	RO Pin Output Logic
M type	$V_{SENSE}/12$	5.0%	Active "H"	Nch open-drain output	Active "L"
N type	$V_{SENSE}/12$	10.0%	Active "H"	Nch open-drain output	Active "L"
Q type	$V_{SENSE}/14$	5.0%	Active "H"	Nch open-drain output	Active "L"
R type	$V_{SENSE}/14$	10.0%	Active "H"	Nch open-drain output	Active "L"

■ AEC-Q100 in Process

Contact our sales representatives for details of AEC-Q100 reliability specification.

■ Product Name Structure

1. Product name

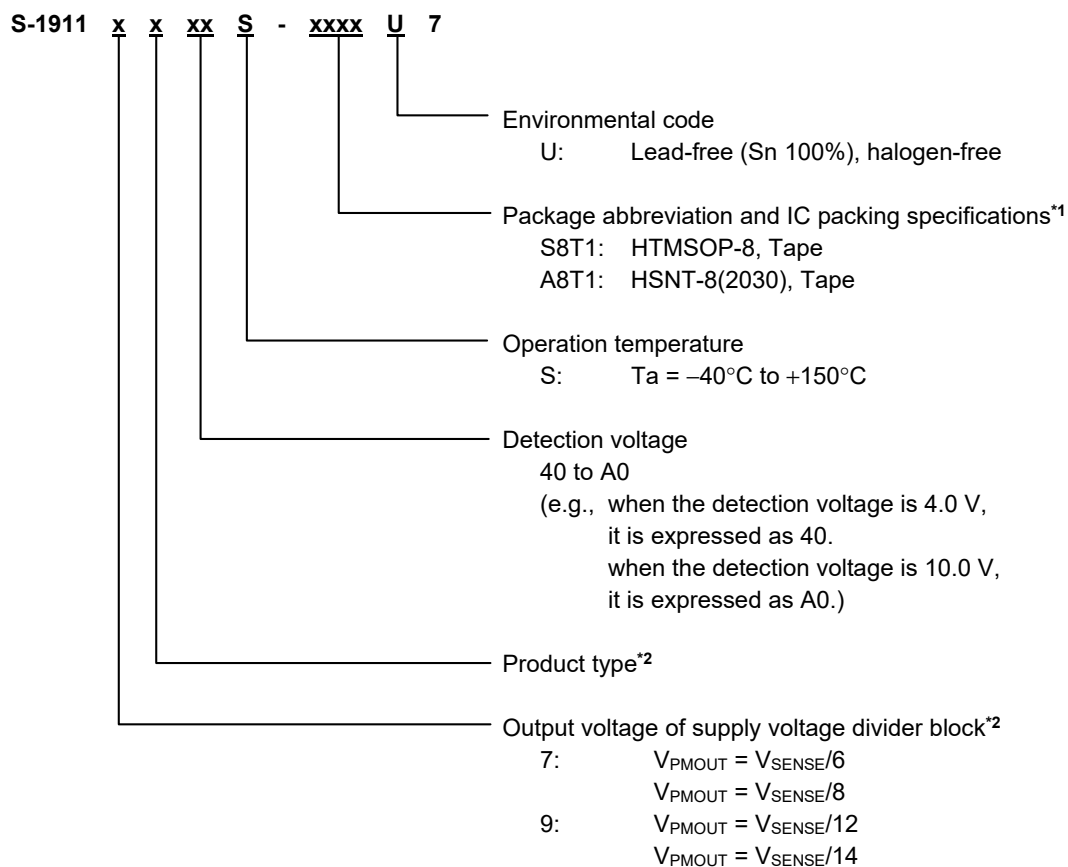

*1. Refer to the tape drawing.

*2. Refer to "2. Function list of product types".

2. Function list of product types

2.1 S-19117 Series

Table 5

Product Type	Output Voltage of Supply Voltage Divider Block (V_{PMOUT})	Hysteresis Width	PMEN Pin Input Logic	RO Pin Output Form	RO Pin Output Logic
L type	$V_{SENSE}/6$	0%	Active "H"	Nch open-drain output	Active "L"
M type	$V_{SENSE}/6$	5.0%	Active "H"	Nch open-drain output	Active "L"
N type	$V_{SENSE}/6$	10.0%	Active "H"	Nch open-drain output	Active "L"
P type	$V_{SENSE}/8$	0%	Active "H"	Nch open-drain output	Active "L"
Q type	$V_{SENSE}/8$	5.0%	Active "H"	Nch open-drain output	Active "L"
R type	$V_{SENSE}/8$	10.0%	Active "H"	Nch open-drain output	Active "L"

2.2 S-19119 Series

Table 6

Product Type	Output Voltage of Supply Voltage Divider Block (V_{PMOUT})	Hysteresis Width	PMEN Pin Input Logic	RO Pin Output Form	RO Pin Output Logic
L type	$V_{SENSE}/12$	0%	Active "H"	Nch open-drain output	Active "L"
M type	$V_{SENSE}/12$	5.0%	Active "H"	Nch open-drain output	Active "L"
N type	$V_{SENSE}/12$	10.0%	Active "H"	Nch open-drain output	Active "L"
P type	$V_{SENSE}/14$	0%	Active "H"	Nch open-drain output	Active "L"
Q type	$V_{SENSE}/14$	5.0%	Active "H"	Nch open-drain output	Active "L"
R type	$V_{SENSE}/14$	10.0%	Active "H"	Nch open-drain output	Active "L"

3. Packages

Table 7 Package Drawing Codes

Package Name	Dimension	Tape	Reel	Land
HTMSOP-8	FP008-A-P-SD	FP008-A-C-SD	FP008-A-R-SD	FP008-A-L-SD
HSNT-8(2030)	PP008-A-P-SD	PP008-A-C-SD	PP008-A-R-SD	PP008-A-L-SD

■ Pin Configurations

1. HTMSOP-8

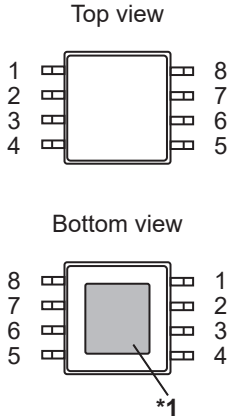

Figure 3

- *1. Connect the heat sink of backside at shadowed area to the board, and set electric potential GND. However, do not use it as the function of electrode.
- *2. Connect a capacitor between the CD pin and the VSS pin. The release delay time can be adjusted according to the capacitance. Moreover, the CD pin is available even when it is open.
- *3. The NC pin is electrically open. The NC pin can be connected to the VDD pin or the VSS pin.

Table 8

Pin No.	Symbol	Description
1	PMEN	Supply voltage divided output enable pin
2	VDD	Voltage input pin
3	PMOUT	Supply voltage divided output pin
4	SENSE	Detection voltage input pin
5	CD*2	Connection pin for release delay time adjustment capacitor
6	VSS	GND pin
7	RO	Voltage detection output pin
8	NC*3	No connection

2. HSNT-8(2030)

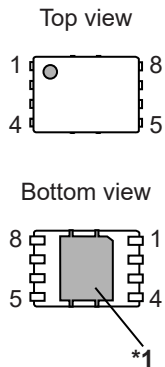

Figure 4

- *1. Connect the heat sink of backside at shadowed area to the board, and set electric potential GND. However, do not use it as the function of electrode.
- *2. Connect a capacitor between the CD pin and the VSS pin. The release delay time can be adjusted according to the capacitance. Moreover, the CD pin is available even when it is open.
- *3. The NC pin is electrically open. The NC pin can be connected to the VDD pin or the VSS pin.

Table 9

Pin No.	Symbol	Description
1	PMEN	Supply voltage divided output enable pin
2	VDD	Voltage input pin
3	PMOUT	Supply voltage divided output pin
4	SENSE	Detection voltage input pin
5	CD*2	Connection pin for release delay time adjustment capacitor
6	VSS	GND pin
7	RO	Voltage detection output pin
8	NC*3	No connection

■ Absolute Maximum Ratings

Table 10

(Ta = -40°C to +150°C unless otherwise specified)

Item	Symbol	Absolute Maximum Rating	Unit	
Power supply voltage	$V_{DD} - V_{SS}$	$V_{SS} - 0.3$ to $V_{SS} + 45.0$	V	
SENSE pin voltage	S-19117 Series L / M / N type	$V_{SS} - 30.0$ to $V_{SS} + 42.0$	V	
	S-19117 Series P / Q / R type	$V_{SS} - 30.0$ to $V_{SS} + 45.0$	V	
	S-19119 Series L / M / N type	$V_{SS} - 30.0$ to $V_{SS} + 45.0$	V	
	S-19119 Series P / Q / R type	$V_{SS} - 30.0$ to $V_{SS} + 45.0$	V	
CD pin input voltage	V_{CD}	$V_{SS} - 0.3$ to $V_{DD} + 0.3 \leq V_{SS} + 7.0$	V	
PMEN pin input voltage	V_{PMEN}	$V_{SS} - 0.3$ to $V_{SS} + 45.0$	V	
Output voltage	Detector block	V_{RO}	$V_{SS} - 0.3$ to $V_{SS} + 45.0$	V
	Supply voltage divider block	V_{PMOUT}	$V_{SS} - 0.3$ to $V_{DD} + 0.3 \leq V_{SS} + 7.0$	V
Output current	I_{OUT}	25	mA	
	I_{PMOUT}	2	mA	
Junction temperature	T_j	-40 to +150	°C	
Operation ambient temperature	T_{opr}	-40 to +150	°C	
Storage temperature	T_{stg}	-40 to +150	°C	

Caution The absolute maximum ratings are rated values exceeding which the product could suffer physical damage. These values must therefore not be exceeded under any conditions.

■ Thermal Resistance Value

Table 11

Item	Symbol	Condition	Min.	Typ.	Max.	Unit	
Junction-to-ambient thermal resistance*1	θ_{JA}	HTMSOP-8	Board A	-	159	-	°C/W
			Board B	-	113	-	°C/W
			Board C	-	39	-	°C/W
			Board D	-	40	-	°C/W
			Board E	-	30	-	°C/W
		HSNT-8(2030)	Board A	-	181	-	°C/W
			Board B	-	135	-	°C/W
			Board C	-	40	-	°C/W
			Board D	-	42	-	°C/W
			Board E	-	32	-	°C/W

*1. Test environment: compliance with JEDEC STANDARD JESD51-2A

Remark Refer to "■ Power Dissipation" and "Test Board" for details.

■ Electrical Characteristics

1. Detector block

Table 12

(Ta = -40°C to +150°C unless otherwise specified)

Item	Symbol	Condition	Min.	Typ.	Max.	Unit	Test Circuit
Detection voltage*1	V _{DET}	V _{DD} = 13.5 V, 4.0 V ≤ V _{DET(S)} ≤ 10.0 V	V _{DET(S)} × 0.98	V _{DET(S)}	V _{DET(S)} × 1.02	V	1
Hysteresis width*2	V _{HYS}	L / P type (V _{HYS} = 0%)	–	V _{DET} × 0.00	–	V	1
		M / Q type (V _{HYS} = 5.0%)	V _{DET} × 0.04	V _{DET} × 0.05	V _{DET} × 0.06	V	1
		N / R type (V _{HYS} = 10.0%)	V _{DET} × 0.09	V _{DET} × 0.10	V _{DET} × 0.11	V	1
Operation voltage	V _{DD}	–	3.0	–	36.0	V	1
Output current	I _{OUT}	RO pin Nch driver, V _{DD} = 3.0 V, V _{DS} *3 = 0.1 V, V _{SENSE} = V _{DET(S)} – 1 V	0.60	–	–	mA	2
Leakage current	I _{LEAK}	RO pin Nch driver, V _{DD} = 36 V, V _{RO} = 36 V, V _{SENSE} = 13.5 V	–	–	2.0	μA	2
Detection response time*4	t _{RESET}	–	–	80	200	μs	3
Release delay time*5	t _{DELAY}	C _D = 3.3 nF	8.0	10.0	12.0	ms	3
SENSE pin resistance	R _{SENSE}	V _{PMEN} = 0 V	6.8	–	200	MΩ	7
CD pin discharge ON resistance	R _{CD}	V _{DD} = 3.0 V, V _{CD} = 0.7 V	0.15	–	0.90	kΩ	–

*1. V_{DET}: Actual Voltage detection voltage value, V_{DET(S)}: Set voltage detection voltage value

*2. The release voltage (V_{REL}) is as follows.

L / P type (hysteresis width "Unavailable"): V_{REL} = V_{DET}

M / N / Q / R type (hysteresis width "Available"): V_{REL} = V_{DET} + V_{HYS}

*3. V_{DS}: Drain-to-source voltage of the output transistor

*4. The time period from when the pulse voltage of V_{DET(S)} + 1.0 V → V_{DET(S)} – 1.0 V is applied to the SENSE pin after V_{SENSE} reaches the release voltage once, until V_{RO} reaches 50% of V_{DD}.

*5. V_{REL(S)}: Set release voltage value

The time period from when the pulse voltage of V_{REL(S)} – 1.0 V → V_{REL(S)} + 1.0 V is applied to the SENSE pin to when V_{RO} reaches 50% of V_{DD}.

2. Supply voltage divider block

Table 13

(Ta = -40°C to +150°C unless otherwise specified)

Item	Symbol	Condition	Min.	Typ.	Max.	Unit	Test Circuit	
Input voltage	V _{DD}	V _{DD} ≥ V _{SENSE} - 2.0 V	3.0	-	36.0	V	-	
SENSE pin voltage	V _{SENSE}	-	5.0	-	36.0	V	-	
Output voltage of supply voltage divider block*1	V _{PMOUT}	3.0 V ≤ V _{DD} ≤ 18.0 V, 5.0 V ≤ V _{SENSE} ≤ 18.0 V, -10 μA ≤ I _{PMOUT} ≤ 10 μA	V _{SENSE} /6 output product	V _{PMOUT(S)} × 0.977	V _{SENSE} /6	V _{PMOUT(S)} × 1.023	V	4
			V _{SENSE} /8 output product	V _{PMOUT(S)} × 0.972	V _{SENSE} /8	V _{PMOUT(S)} × 1.028	V	4
			V _{SENSE} /12 output product	V _{PMOUT(S)} × 0.967	V _{SENSE} /12	V _{PMOUT(S)} × 1.033	V	4
		3.0 V ≤ V _{DD} ≤ 18.0 V, 5.0 V ≤ V _{SENSE} ≤ 18.0 V, -3 μA ≤ I _{PMOUT} ≤ 3 μA	V _{SENSE} /14 output product	V _{PMOUT(S)} × 0.963	V _{SENSE} /14	V _{PMOUT(S)} × 1.037	V	4
Load current	I _{PMOUT}	V _{SENSE} /6 output product, V _{SENSE} /8 output product, V _{SENSE} /12 output product	-10	-	10	μA	4	
		V _{SENSE} /14 output product	-3	-	3	μA	4	
Output impedance	R _{PS}	3.0 V ≤ V _{DD} ≤ 18.0 V, 5.0 V ≤ V _{SENSE} ≤ 18.0 V	-	-	1000	Ω	4	
Set-up time*2	t _{PU}	V _{DD} = 18.0 V, V _{SENSE} = 18.0 V, C _{PM} = 0.22 μF, no load, t _r = 1.0 μs	-	15	30	ms	5	
PMEN pin input voltage "H"	V _{PSH}	V _{DD} = 18.0 V, determined by V _{PMOUT} output level	1.3	-	-	V	6	
PMEN pin input voltage "L"	V _{PSL}	V _{DD} = 18.0 V, determined by V _{PMOUT} output level	-	-	0.3	V	6	
PMEN pin input current "H"	I _{PSH}	V _{DD} = 18.0 V, V _{PMEN} = V _{DD}	0.00	-	0.50	μA	6	
PMEN pin input current "L"	I _{PSL}	V _{DD} = 18.0 V, V _{PMEN} = 0 V	-0.1	-	0.1	μA	6	
SENSE pin resistance during operation of supply voltage divider block	R _{PMSENSE}	V _{PMEN} = V _{DD}	5.8	-	140	MΩ	7	
Discharge shunt resistance during power-off	R _{PLow}	V _{DD} = 13.5 V, V _{PMEN} = 0 V, V _{PMOUT} = 0.1 V	-	2.8	-	kΩ	8	

*1. V_{PMOUT}: Actual output voltage value of supply voltage divider block,
 V_{PMOUT(S)}: Set output voltage value of supply voltage divider block

*2. Set-up time shows the time period from when the input voltage reaches 50% until the output voltage of supply voltage divider block rises to 99%, when the PMEN pin is set to ON (t_r = 1.0 μs).

3. Overall

Table 14

(Ta = -40°C to +150°C unless otherwise specified)

Item	Symbol	Condition	Min.	Typ.	Max.	Unit	Test Circuit
Current consumption	I _{SS1}	During supply voltage divided output stops, V _{DD} = 13.5 V, V _{SENSE} = 13.5 V, V _{PMEN} = 0 V	-	0.75	3.0	μA	7
	I _{SSP1}	During supply voltage divided output operates, V _{DD} = 13.5 V, V _{SENSE} = 13.5 V, V _{PMEN} = V _{DD} , no load	-	1.15	5.4	μA	7

■ Test Circuits

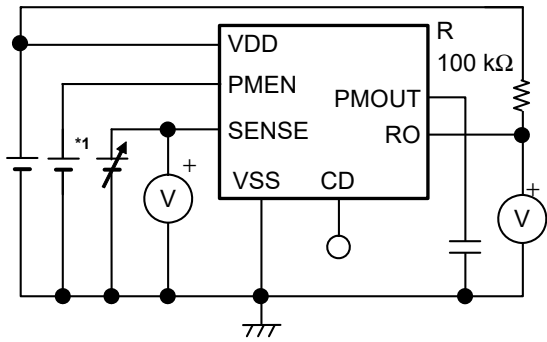

*1. Set to ON

Figure 5 Test Circuit 1

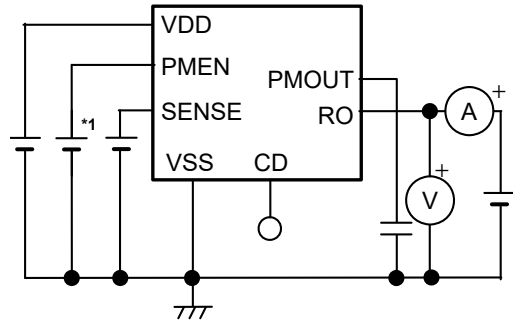

*1. Set to ON

Figure 6 Test Circuit 2

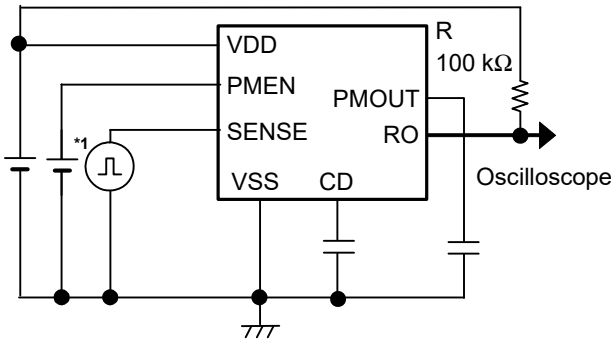

*1. Set to ON

Figure 7 Test Circuit 3

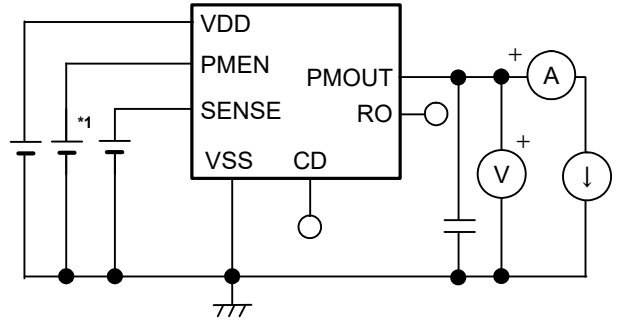

*1. Set to ON

Figure 8 Test Circuit 4

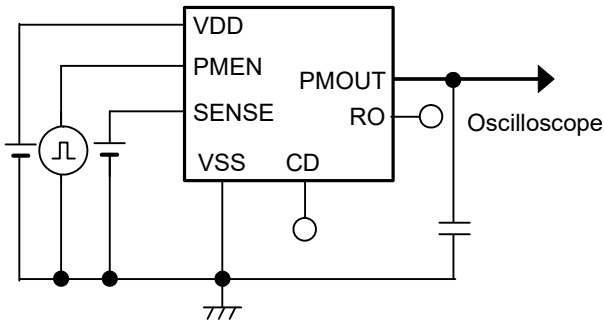
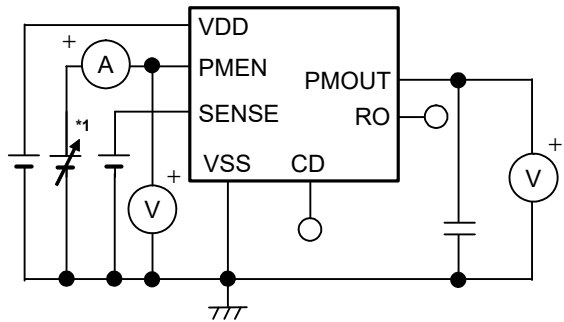
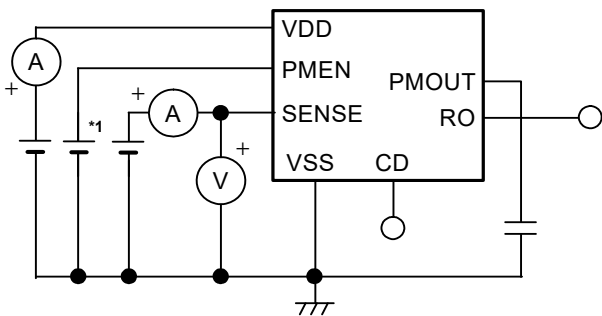

Figure 9 Test Circuit 5



*1. Set to ON or OFF

Figure 10 Test Circuit 6



*1. Set to ON or OFF

Figure 11 Test Circuit 7

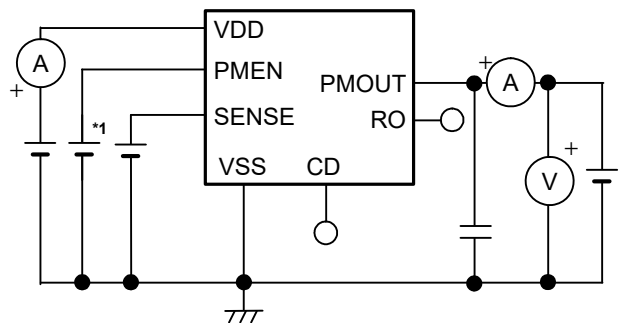

*1. Set to OFF

Figure 12 Test Circuit 8

■ Standard Circuit

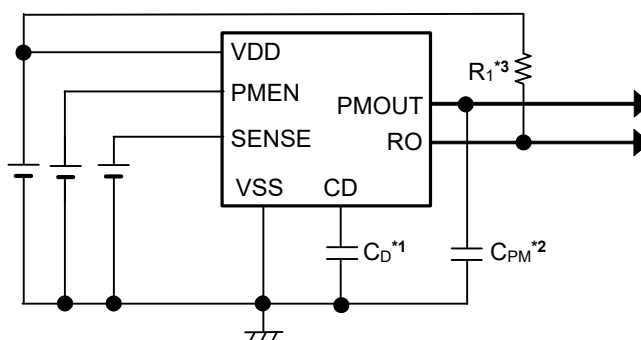

- *1. C_D is a release delay time adjustment capacitor. The C_D should be connected directly to the CD pin and the VSS pin.
- *2. C_{PM} is a capacitor for stabilizing the output. The C_{PM} should be connected directly to the PMOUT pin and the VSS pin.
- *3. R_1 are the external pull-up resistors for the reset output pin.

Figure 13

Caution The above connection diagram and constants will not guarantee successful operation. Perform thorough evaluation including the temperature characteristics with an actual application to set the constants.

■ Condition of Application

Release delay time adjustment capacitor (C_D): A ceramic capacitor with capacitance of 1.0 nF or more is recommended.
 Supply voltage divider block output capacitor (C_{PM}): A ceramic capacitor with capacitance of 0.1 μ F to 0.22 μ F is recommended.

- Caution**
1. The CD pin is available even when it is open.
 Refer to "1. Power on sequence" in "■ Usage Precautions" when using it open.
 2. Generally, in a supply voltage divider, an oscillation may occur depending on the selection of the external parts. Perform thorough evaluation including the temperature characteristics with an actual application using the above capacitors to confirm no oscillation occurs.

■ Selection of Release Delay Time Adjustment Capacitor (C_D)

In this IC, the release delay time adjustment capacitor (C_D) is necessary between the CD pin and the VSS pin to adjust the release delay time (t_{DELAY}) of the detector. Refer to "1. 4 Delay circuit" in "■ Operation" for details.

Caution Perform thorough evaluation including the temperature characteristics with an actual application to select C_D .

■ Selection of Supply Voltage Divider Block Output Capacitor (C_{PM})

This IC requires C_{PM} between the PMOUT pin and the VSS pin for phase compensation. The operation is stabilized by a ceramic capacitor with capacitance of 0.1 μ F to 0.22 μ F. When using an OS capacitor, a tantalum capacitor or an aluminum electrolytic capacitor, the capacitance also must be 0.1 μ F to 0.22 μ F. However, an oscillation may occur depending on the equivalent series resistance (ESR).

Caution Perform thorough evaluation including the temperature characteristics with an actual application to select C_{PM} .

■ Explanation of Terms

1. Detector block

1.1 Detection voltage (V_{DET})

The detection voltage is a SENSE pin voltage at which the output voltage in **Figure 16** turns to "L". The detection voltage varies slightly among products of the same specification. The variation of detection voltage between the specified minimum and the maximum is called the detection voltage range (Refer to "**Figure 14 Detection Voltage**").

Example: In $V_{DET} = 4.0$ V product, the detection voltage is at any point in the range of $3.920 \text{ V} \leq V_{DET} \leq 4.080 \text{ V}$.
This means that some $V_{DET} = 4.0$ V product has $V_{DET} = 3.920$ V and some has $V_{DET} = 4.080$ V.

1.2 Release voltage (V_{REL})

The release voltage is a SENSE pin voltage at which the output voltage in **Figure 16** turns to "H". The release voltage varies slightly among products of the same specification. The variation of release voltage between the specified minimum and the maximum is called the release voltage range (Refer to "**Figure 15 Release Voltage**"). The release voltage becomes the value differs from the detection voltage within the range shown below.

- M / Q type: 4% to 6% (5% typ.)
- N / R type: 9% to 11% (10% typ.)

Example: For N / R type, $V_{DET} = 4.0$ V product, the release voltage is at any point in the range of $4.272 \text{ V} \leq V_{REL} \leq 4.529 \text{ V}$ despite $V_{REL} = 4.400$ V typ.
This means that some N / R type, $V_{DET} = 4.0$ V product has $V_{REL} = 4.272$ V and some has $V_{REL} = 4.529$ V.

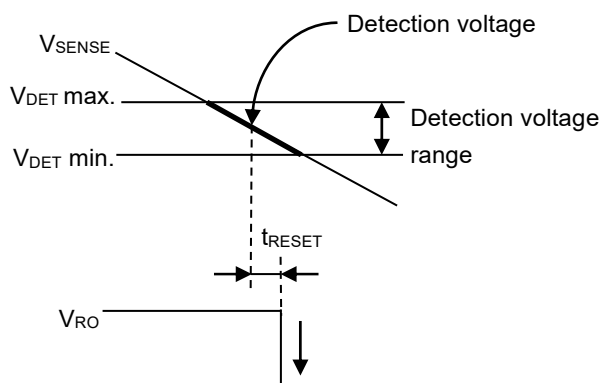

Figure 14 Detection Voltage

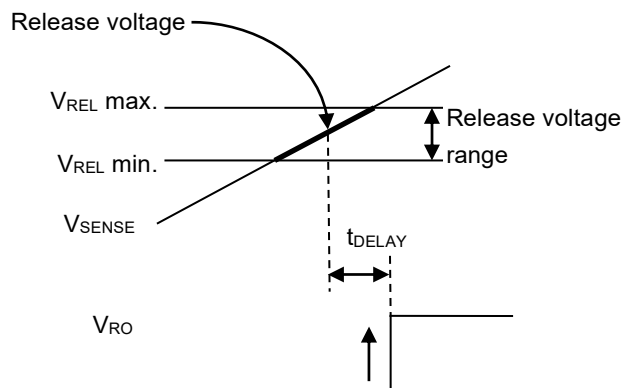

Figure 15 Release Voltage

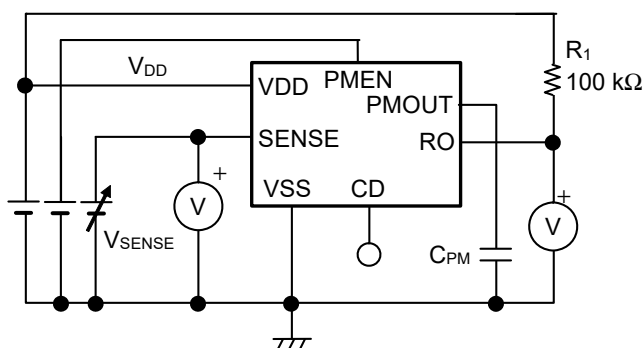

Figure 16 Test Circuit of Detection Voltage and Release Voltage

1.3 Hysteresis width (V_{HYS})

The hysteresis width is the voltage difference between the detection voltage (V_{DET}) and the release voltage (V_{REL}). Voltage difference between V_{REL} and V_{DET} is the hysteresis width (V_{HYS}^{*1}) of the RO pin. Setting the hysteresis width between V_{DET} and V_{REL} , prevents malfunction caused by noise on the input voltage.

*1. Refer to "1.2 S-19117/19119 Series M / N / Q / R type" in "■ Operation" for details.

1.4 Feed-through current

The feed-through current is a current that flows instantaneously to the VDD pin at the time of detection and release of a voltage detector.

2. Supply voltage divider block

2.1 Supply voltage divided output

The supply voltage divided output is a function that divides the SENSE pin voltage (V_{SENSE}) into $V_{SENSE}/6$, $V_{SENSE}/8$, $V_{SENSE}/12$ or $V_{SENSE}/14$ and outputs the voltage.

For example, a microcontroller can monitor a battery voltage by inputting the output voltage of supply voltage divider block (V_{PMOUT}) to the microcontroller A/D converter.

2.2 Output voltage of supply voltage divider block (V_{PMOUT})

This is the voltage of the divided V_{SENSE} . The following voltages are the outputs.

- S-19117 Series L / M / N type: $V_{SENSE}/6$
- S-19117 Series P / Q / R type: $V_{SENSE}/8$
- S-19119 Series L / M / N type: $V_{SENSE}/12$
- S-19119 Series P / Q / R type: $V_{SENSE}/14$

This voltage is the output in accuracy range of between $\pm 2.3\%$ and $\pm 3.7\%^{*1}$ when the power supply voltage, V_{SENSE} , temperature and load current satisfy a certain condition^{*1}.

*1. Differs depending on the product type.

Example: For S-19117 Series L / M / N type, $V_{SENSE} = 15.0$ V, the output voltage of supply voltage divider block is at any point in the range of 2.442 V $\leq V_{PMOUT} \leq 2.558$ V.

This means that some S-19117 Series L / M / N type has $V_{PMOUT} = 2.442$ V and some has $V_{PMOUT} = 2.558$ V.

Caution If the certain condition is not satisfied, the output voltage may exceed the accuracy range. Refer to Table 13 of "■ Electrical Characteristics" for details.

2.3 Output impedance (R_{PS})

This is the supply voltage divider block impedance. It shows how much output offset voltage changes when the load current changes.

For example, the output impedance can be used in sampling rate calculation as signal source impedance when V_{PMOUT} from the PMOUT pin is input to the A/D converter as a microcontroller input signal.

2.4 Set-up time (t_{PU})

This is the time from when the supply voltage divided output is operated until V_{PMOUT} stabilizes.

2.5 Discharge shunt resistance during power-off (R_{PLow})

This is the ON resistance of the N-channel transistor built into the supply voltage divider block.

When the supply voltage divided output is stopped, V_{PMOUT} is set to the V_{SS} level by the built-in N-channel transistor.

■ Operation

1. Detector block

Figure 17 and Figure 19 show that the RO pin being pulled up by resistors (R_1) is an example of basic detector block operation.

1.1 S-19117/19119 Series L / P type

- (1) When the power supply voltage (V_{DD}) is the minimum operation voltage or higher, and the SENSE pin voltage (V_{SENSE}) is the release voltage (V_{REL}) or higher, the Nch transistor is turned off to output V_{DD} ("H") when the output is pulled up.

At this time, the input voltage to the comparator is $\frac{(R_B + R_C) \cdot V_{SENSE}}{R_A + R_B + R_C}$.

- (2) When V_{SENSE} decreases to the detection voltage (V_{DET}) or lower (point A in Figure 18), the Nch transistor is turned on. And then V_{SS} ("L") is output from the RO pin after the elapse of the detection response time (t_{RESET}).
- (3) Even if V_{SENSE} further decreases to the IC's minimum operation voltage or lower, the output from the RO pin is stable when V_{DD} is minimum operation voltage or higher.
- (4) Even if V_{SENSE} increases, V_{SS} is output when V_{SENSE} is lower than V_{REL} .
- (5) When V_{SENSE} increases to V_{REL} or higher (point B in Figure 18), the Nch transistor is turned off. And then V_{DD} is output from the RO pin after the elapse of the release delay time (t_{DELAY}) when the output is pulled up.

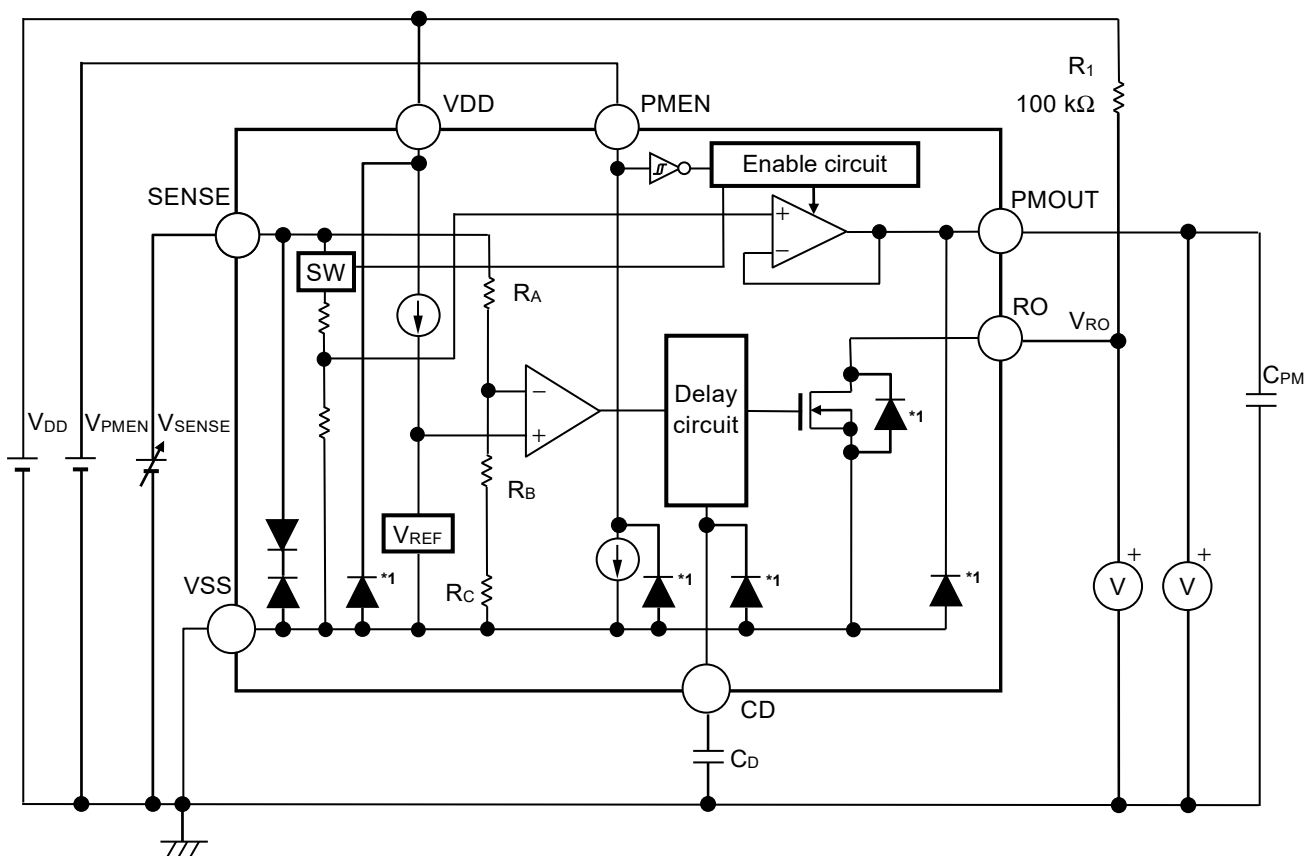

*1. Parasitic diode

Figure 17 Operation of S-19117/19119 Series L / P type

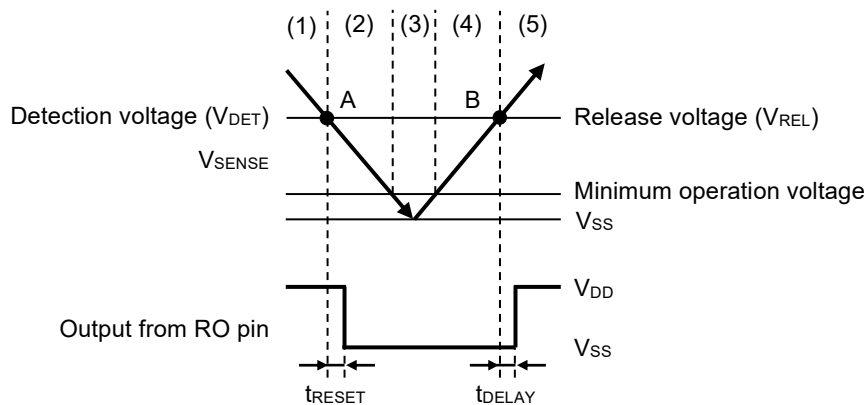

Remark The release voltage is set to the same value as the detection voltage, since there is no hysteresis width.

Figure 18 Timing Chart of S-19117/19119 Series L / P Type

1.2 S-19117/19119 Series M / N / Q / R type

(1) When the power supply voltage (V_{DD}) is the minimum operation voltage or higher, and the SENSE pin voltage (V_{SENSE}) is the release voltage (V_{REL}) or higher, the Nch transistor is turned off to output V_{DD} ("H") when the output is pulled up.

Since the Nch transistor (N1) is turned off, the input voltage to the comparator is $\frac{(R_B + R_C) \cdot V_{SENSE}}{R_A + R_B + R_C}$.

(2) Even if V_{SENSE} decreases to V_{REL} or lower, V_{DD} is output when V_{SENSE} is higher than the detection voltage (V_{DET}). When V_{SENSE} decreases to V_{DET} or lower (point A in **Figure 20**), the Nch transistor is turned on. And then V_{SS} ("L") is output from the RO pin after the elapse of the detection response time (t_{RESET}).

At this time, N1 is turned on, and the input voltage to the comparator is $\frac{R_B \cdot V_{SENSE}}{R_A + R_B}$.

(3) Even if V_{SENSE} further decreases to the IC's minimum operation voltage or lower, the output from the RO pin is stable when V_{DD} is minimum operation voltage or higher.

(4) Even if V_{SENSE} exceeds V_{DET} , V_{SS} is output when V_{SENSE} is lower than V_{REL} .

(5) When V_{SENSE} increases to V_{REL} or higher (point B in **Figure 20**), the Nch transistor is turned off. And then V_{DD} is output from the RO pin after the elapse of the release delay time (t_{DELAY}) when the output is pulled up.

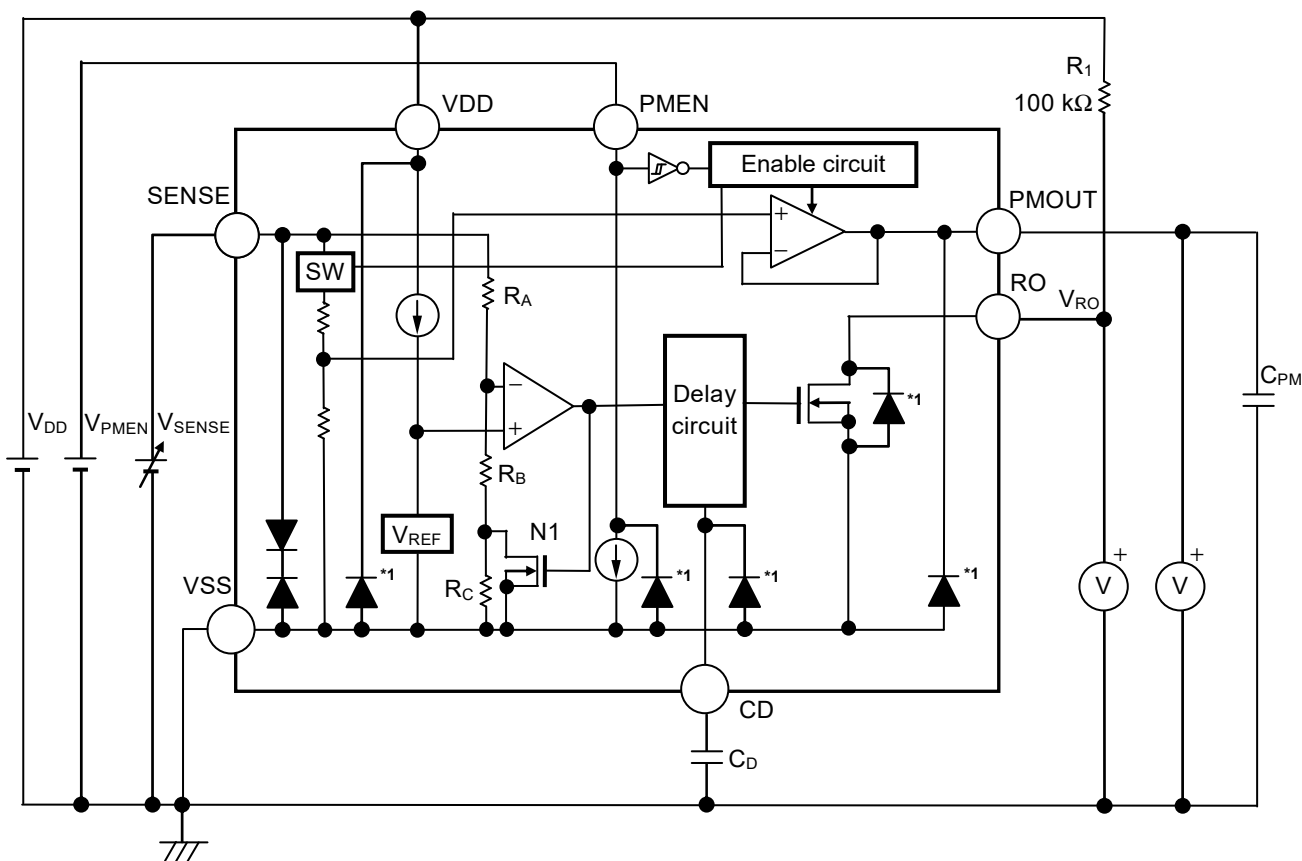

*1. Parasitic diode

Figure 19 Operation of S-19117/19119 Series M / N / Q / R type

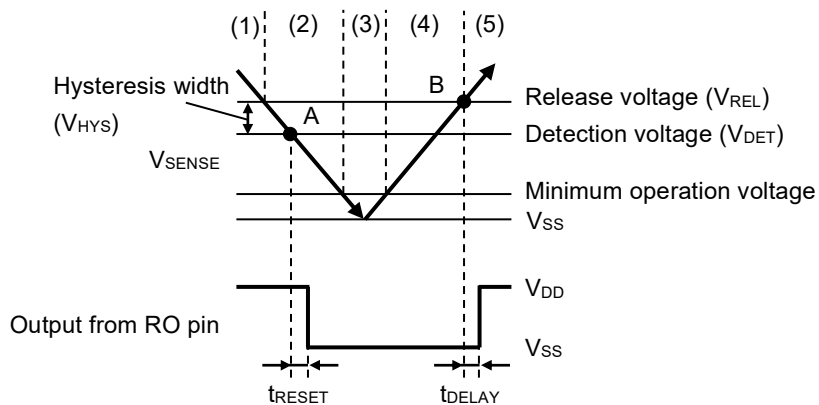

Figure 20 Timing Chart of S-19117/19119 Series M / N / Q / R Type

1.3 SENSE pin

The SENSE pin is the input pin for the detection voltage. The power supply VDD pin and SENSE pin, for voltage detection, are divided. Therefore, as long as a voltage is supplied to the VDD pin, the reset signal will be held even if the input voltage to the SENSE pin drops below the minimum operation voltage. Also, the SENSE pin of this IC has a built-in reverse connection protection circuit. Even when the SENSE pin voltage is less than the VSS pin voltage, the voltage flowing from the VSS pin to the SENSE pin is reduced to 0.05 mA typ.

1.3.1 Error when detection voltage is set externally

The detection voltage can be set externally by connecting a node that was resistance-divided by the resistor (R_A) and the resistor (R_B) to the SENSE pin as shown in **Figure 21**.

For conventional products without the SENSE pin, external resistor cannot be too large since the resistance-divided node must be connected to the VDD pin. This is because a feed-through current will flow through the VDD pin when it goes from detection to release, and if external resistor is large, problems such as oscillation or larger error in the hysteresis width may occur.

In this IC, R_A and R_B in **Figure 21** are easily made larger since the resistance-divided node can be connected to the SENSE pin through which no feed-through current flows. However, be careful of error in the current flowing through the internal resistance (R_{SENSE}) that will occur.

Although R_{SENSE}^{*1} in this IC is large to make the error small, R_A and R_B should be selected such that the error is within the allowable limits.

Please note that the supply voltage divided output is a function to divide and output the SENSE pin voltage so when the detection voltage is set externally, care is required as the supply voltage divider block output voltage will change.

- *1. During supply voltage divided output stops: 6.8 M Ω min.
During supply voltage divided output operates: 5.8 M Ω min.

1.3.2 Selection of R_A and R_B

In **Figure 21**, the relation between the external setting detection voltage (V_{DX}) and the actual detection voltage (V_{DET}) is ideally calculated by the equation below.

$$V_{DX} = V_{DET} \times \left(1 + \frac{R_A}{R_B}\right) \dots\dots\dots(1)$$

However, in reality there is an error in the current flowing through R_{SENSE} .
 When considering this error, the relation between V_{DX} and V_{DET} is calculated as follows.

$$\begin{aligned} V_{DX} &= V_{DET} \times \left(1 + \frac{R_A}{R_B \parallel R_{SENSE}}\right) \\ &= V_{DET} \times \left(1 + \frac{R_A}{\frac{R_B \times R_{SENSE}}{R_B + R_{SENSE}}}\right) \\ &= V_{DET} \times \left(1 + \frac{R_A}{R_B}\right) + \frac{R_A}{R_{SENSE}} \times V_{DET} \dots\dots\dots(2) \end{aligned}$$

By using equations (1) and (2), the error is calculated as $V_{DET} \times \frac{R_A}{R_{SENSE}}$.

The error rate is calculated as follows by dividing the error by the right-hand side of equation (1).

$$\frac{R_A \times R_B}{R_{SENSE} \times (R_A + R_B)} \times 100 [\%] = \frac{R_A \parallel R_B}{R_{SENSE}} \times 100 [\%] \dots\dots(3)$$

As seen in equation (3), the smaller the resistance values of R_A and R_B compared to R_{SENSE} , the smaller the error rate becomes.

Also, the relation between the external setting hysteresis width (V_{HX}) and the hysteresis width (V_{HYS}) is calculated by equation below. Error due to R_{SENSE} also occurs to the relation in a similar way to the detection voltage.

$$V_{HX} = V_{HYS} \times \left(1 + \frac{R_A}{R_B}\right) \dots\dots\dots(4)$$

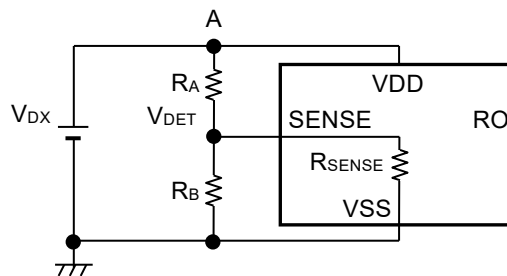

Figure 21 Detection Voltage External Setting Circuit

Caution If R_A and R_B are large, the SENSE pin input impedance becomes higher and may cause a malfunction due to noise. In this case, connect a capacitor between the SENSE pin and the VSS pin.

1.4 Delay circuit

The delay circuit has a function that adjusts the release delay time (t_{DELAY}) from when the SENSE pin voltage (V_{SENSE}) reaches the release voltage ($V_{REL} = V_{DET} + V_{HYS}$) or higher to when the output from RO pin inverts.

t_{DELAY} is determined by the delay coefficient, the release delay time adjustment capacitor (C_D) and the release delay time when the CD pin is open (t_{DELAY0}). They are calculated by the equations below.

$$t_{DELAY} [\text{ms}] = \text{Delay coefficient} \times C_D [\text{nF}] + t_{DELAY0} [\text{ms}]$$

Table 15

Operation Temperature	Delay Coefficient		
	Min.	Typ.	Max.
Ta = +150°C	2.52	3.00	3.58
Ta = +125°C	2.65	3.03	3.41
Ta = +25°C	2.92	3.06	3.14
Ta = -40°C	2.65	3.09	3.41

Table 16

Operation Temperature	Release Delay Time when CD Pin is Open (t_{DELAY0})		
	Min.	Typ.	Max.
Ta = +150°C	0.05	0.09	0.16
Ta = +125°C	0.05	0.09	0.17
Ta = +25°C	0.06	0.11	0.19
Ta = -40°C	0.06	0.13	0.25

- Caution 1.** Mounted board layout should be made in such a way that no current flows into or flows from the CD pin since the impedance of the CD pin is high, otherwise correct delay time cannot be provided.
2. There is no limit for the capacitance of C_D as long as the leakage current of the capacitor can be ignored against the built-in constant current value (approximately 160 nA). The leakage current may cause error in delay time. When the leakage current is larger than the built-in constant current, no detect or release takes place.
 3. The above equations will not guarantee successful operation. Determine the capacitance of C_D through thorough evaluation including temperature characteristics in the actual usage conditions.

2. Supply voltage divider block

2.1 Basic operation

Figure 22 shows the block diagram of the supply voltage divider block to describe basic operation.

Reference voltage (V_{refpm}) is generated by dividing the SENSE pin voltage (V_{SENSE}) using the dividing resistance (R_{pm1} and R_{pm2}). Since the buffer amplifier constitutes a voltage follower, it can perform the feedback control so that the output voltage of supply voltage divider block (V_{PMOUT}) and V_{refpm} are the same. Low output impedance is realized by the buffer amplifier, while outputting V_{PMOUT} according to V_{SENSE} .

When "L" is input to the PMEN pin, the current which flows to R_{pm1} and R_{pm2} and the current which flows to the buffer amplifier can be stopped. The buffer amplifier output is pulled down to V_{SS} by the built-in N-channel transistor, and V_{PMOUT} is set to the V_{SS} level.

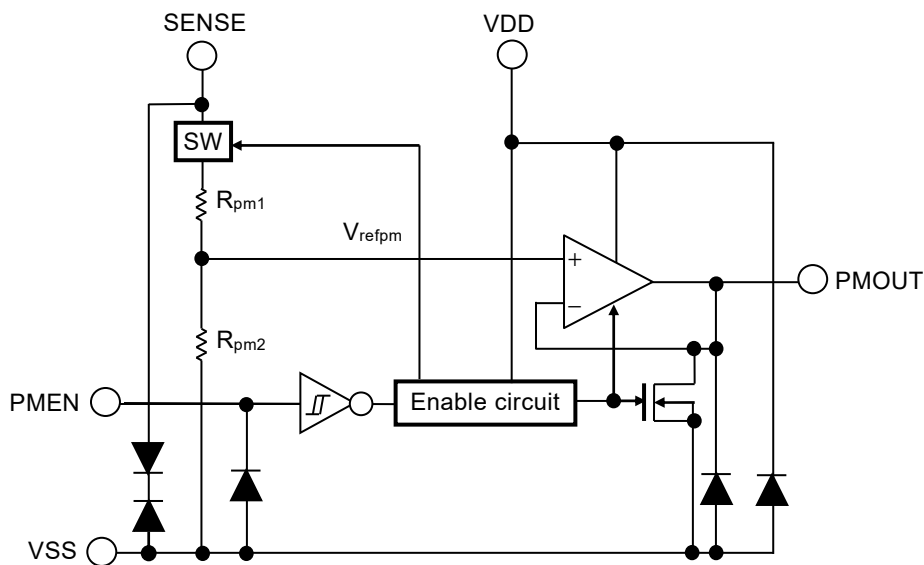

Figure 22

2.2 PMEN pin

Input to the PMEN pin controls the internal circuit in the supply voltage divided output, and it starts or stops the supply voltage divided output.

When the PMEN pin is set to "L" level, the internal circuit stops operating, reducing current consumption significantly. In addition, the PMEN pin has absolutely no effect on the operation of the detector block.

Note that the current consumption increases when a voltage of 0.8 V to $V_{DD} \text{ min.} - 0.3 \text{ V}$ is applied to the PMEN pin. The PMEN pin is configured as shown in **Figure 23**.

Since the PMEN pin is internally pulled down to the VSS pin in the floating status, the PMOUT pin is set to the VSS level. When the PMEN pin is set to "H" level, PMEN pin input current "H" (I_{PSH}) in **Table 13** of "■ Electrical Characteristics" flows through the PMEN pin and care is required.

Table 17

Product Type	PMEN Pin	Internal Circuit	PMOUT Pin Output	Current Consumption
L / M / N / P / Q / R	"H": ON	Operate	Constant value*1	I_{SSP1}
L / M / N / P / Q / R	"L": OFF	Stop	Pulled down to V_{SS} *2	I_{SS1}

*1. The constant value is output due to the operation based on the set output voltage value of supply voltage divider block.

*2. The buffer amplifier output is pulled down to V_{SS} by the built-in N-channel transistor, and PMOUT pin output is set to the V_{SS} level due to resistance ($R_{Low} = 2.8 \text{ k}\Omega \text{ typ.}$) of the discharge shunt circuit and a load.

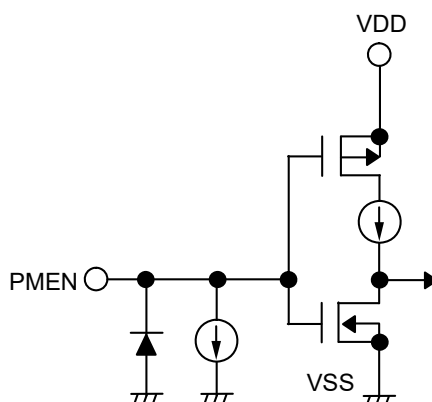

Figure 23

2.3 PMEN pin voltage and output voltage of supply voltage divider block (V_{PMOUT})

Figure 24 shows the timing chart of the supply voltage divided output.

When "H" is input to the PMEN pin, the supply voltage divided output operates. When the set-up time (t_{PU}) = 50 ms max.*1 elapses, V_{PMOUT} stabilizes, the SENSE pin voltage (V_{SENSE}) is divided at the set ratio, and the voltage is output to the PMOUT pin.

When "L" is input to the PMEN pin, the supply voltage divided output is stopped. V_{PMOUT} is set to the V_{SS} level by the built-in N-channel transistor.

By repeatedly inputting "H" and "L" to the PMEN pin, it is possible to lower current consumption when the supply voltage divided output is not needed.

*1. When $5\text{ V} \leq V_{SENSE} \leq 18\text{ V}$, $C_{PM} = 0.22\ \mu\text{F}$, no load

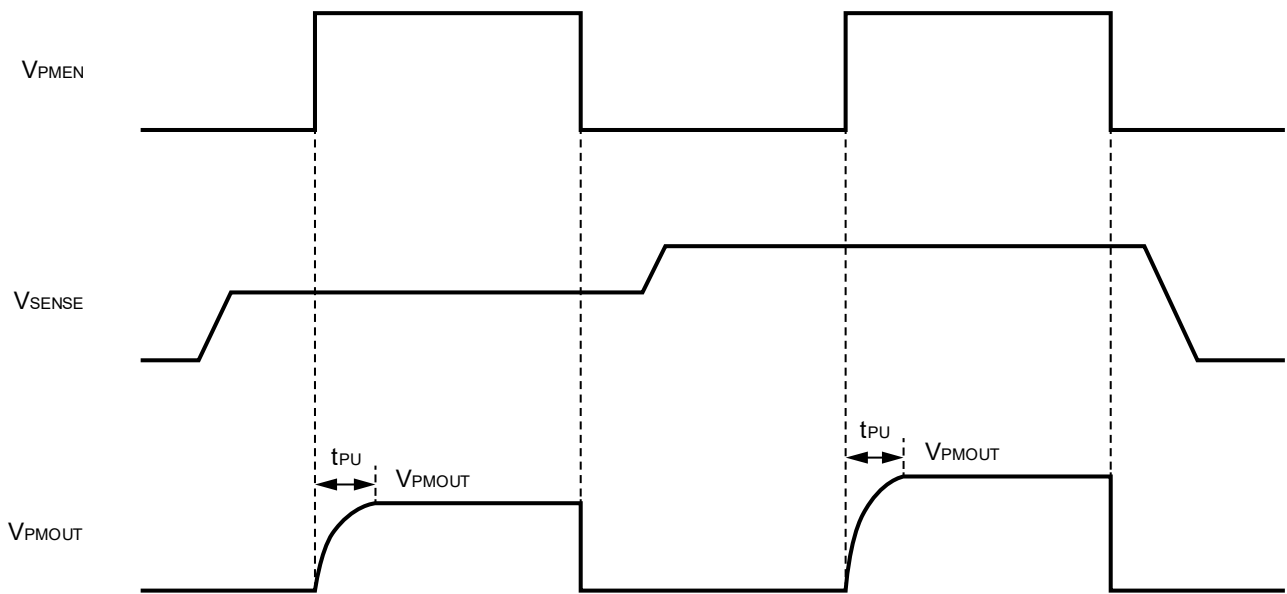

Figure 24

Remark $V_{PMEN} = V_{DD} \leftrightarrow V_{SS}$

■ Usage Precautions

1. Power on sequence

1.1 Power on when release delay time adjustment capacitor (C_D) ≥ 1 nF

When connecting a 1 nF or larger capacitor to the CD pin, there is no specific order for turning on the SENSE and VDD pins.

1.2 Power on when release delay time adjustment capacitor (C_D) < 1 nF or CD pin is open

When connecting a capacitor of less than 1 nF to the CD pin, turn on the VDD pin before the SENSE pin as shown in **Figure 25**.

When $V_{SENSE} \geq V_{REL}$ applies, output voltage (V_{RO}) becomes "H", and the detector enters release status.

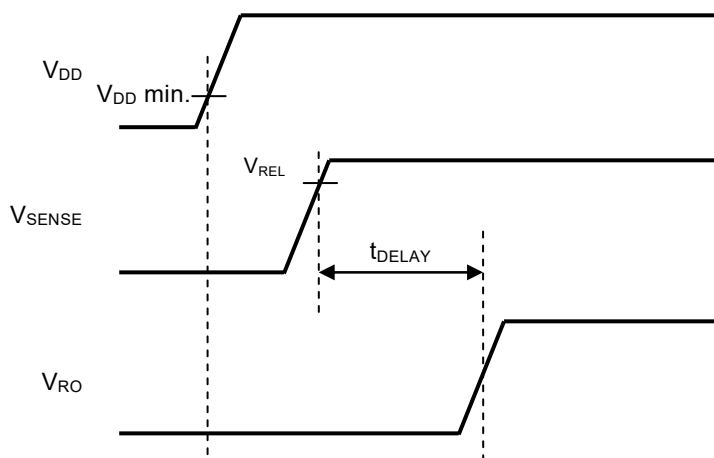

Figure 25

Caution When connecting a capacitor of less than 1 nF to the CD pin and the SENSE pin is turned on before the VDD pin, a release may mistakenly occur even if V_{SENSE} is less than V_{REL} .

■ Precautions

- Do not apply an electrostatic discharge to this IC that exceeds the performance ratings of the built-in electrostatic protection circuit.
- Because the SENSE pin has a high impedance, malfunctions may occur due to noise.
Be careful of wiring adjoining SENSE pin wiring in actual applications.
- In the supply voltage divided output, the values of an overshoot and an undershoot in the output voltage vary depending on the variation factors of input voltage start-up, input voltage fluctuation and load fluctuation etc., or the capacitance of C_{PM} and the value of the equivalent series resistance (ESR), which may cause a problem to the stable operation. Perform thorough evaluation including the temperature characteristics with an actual application to select C_{PM} .
- When designing for mass production using an application circuit described herein, the product deviation and temperature characteristics should be taken into consideration. ABLIC Inc. shall not bear any responsibility for patent infringements related to products using the circuits described herein.
- ABLIC Inc. claims no responsibility for any disputes arising out of or in connection with any infringement by products including this IC of patents owned by a third party.

■ Characteristics (Typical Data)

1. Detector block

1.1 Detection voltage (V_{DET}), Release voltage (V_{REL}) vs. Temperature (T_a)

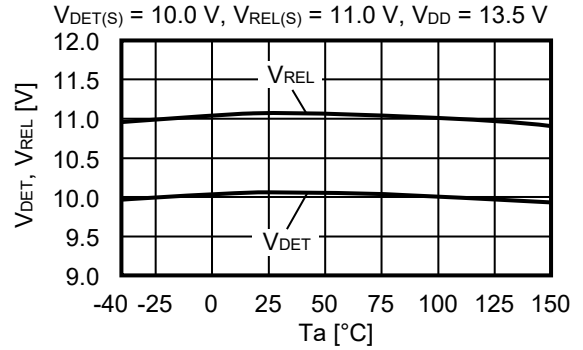
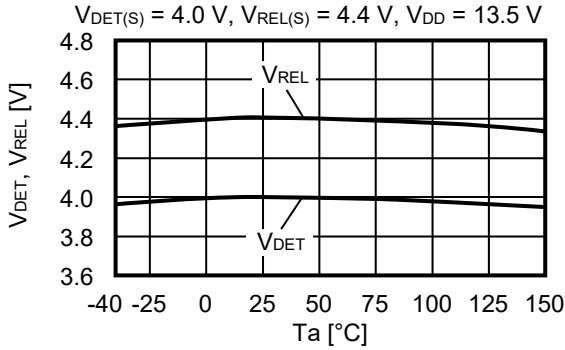

1.2 Detection voltage (V_{DET}), Release voltage (V_{REL}) vs. Power supply voltage (V_{DD})

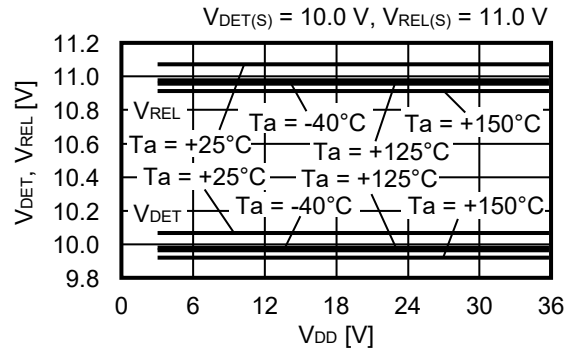
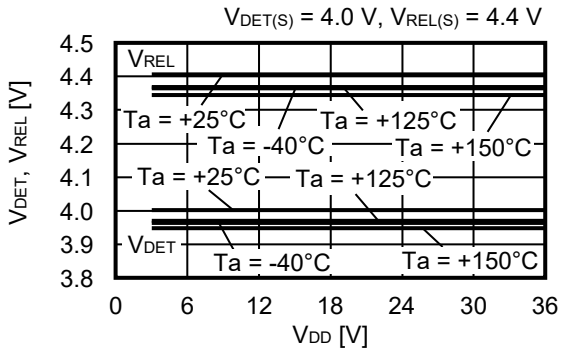

1.3 Hysteresis width (V_{HYS}) vs. Temperature (T_a)

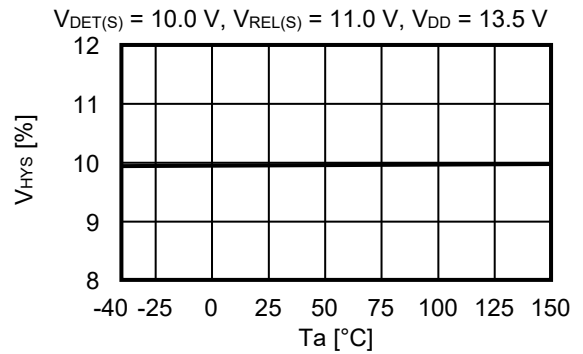
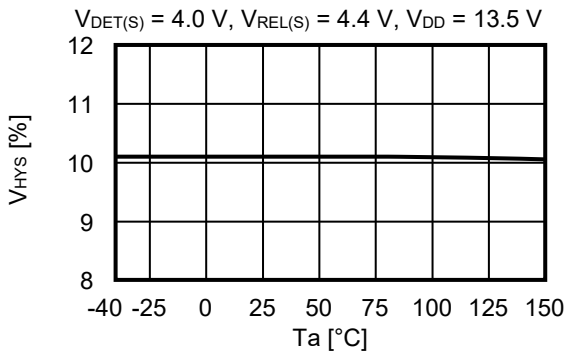

1.4 Hysteresis width (V_{HYS}) vs. Power supply voltage (V_{DD})

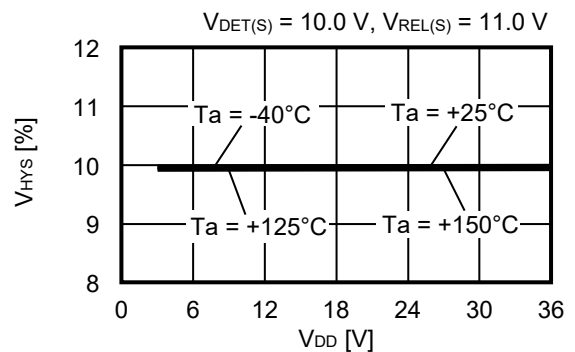
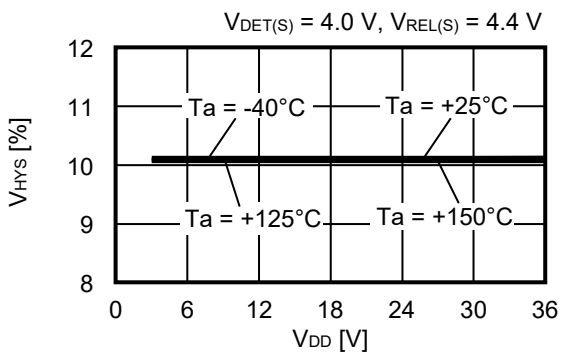

1.5 Nch transistor output current (I_{OUT}) vs. V_{DS}

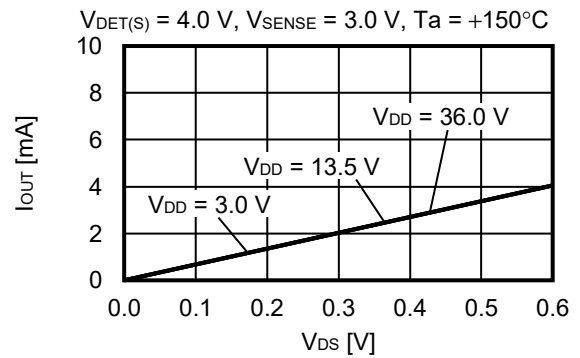
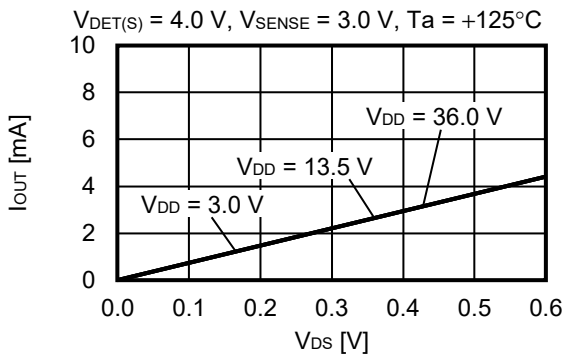
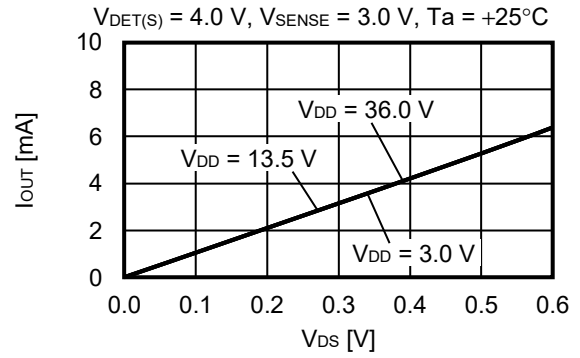
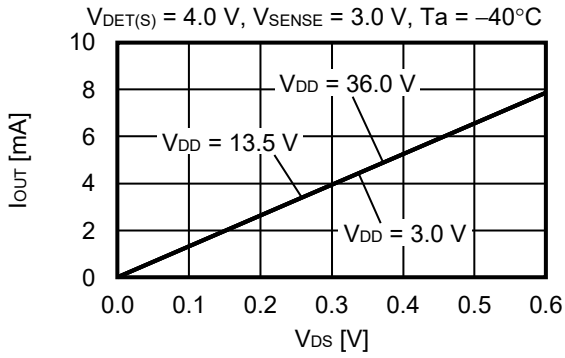

Remark V_{DS} : Drain-to-source voltage of the output transistor

1.6 Nch transistor output current (I_{OUT}) vs. Power supply voltage (V_{DD})

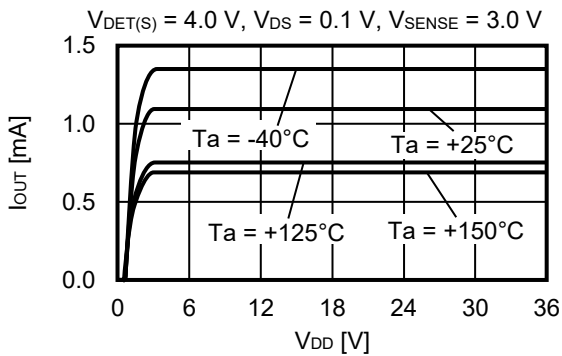

Remark V_{DS} : Drain-to-source voltage of the output transistor

1.7 Output voltage (V_{RO}) vs. SENSE pin voltage (V_{SENSE})

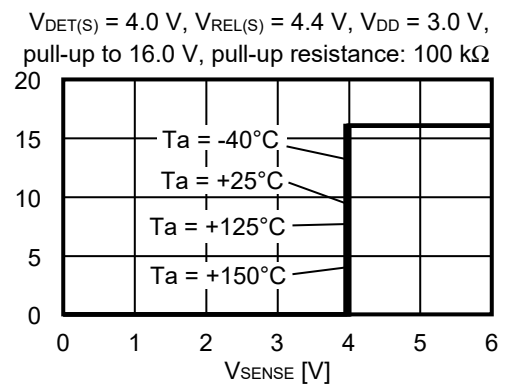
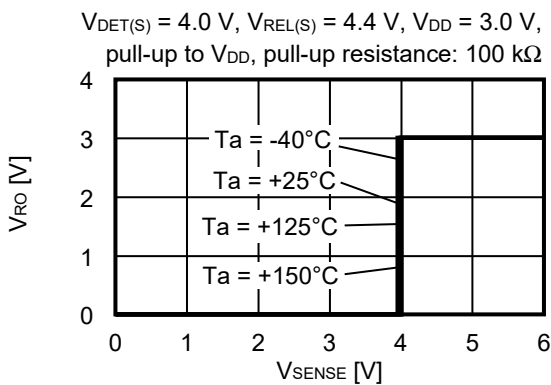

1.8 Dynamic response vs. Output pin capacitance (C_{OUT}) (CD pin; open)

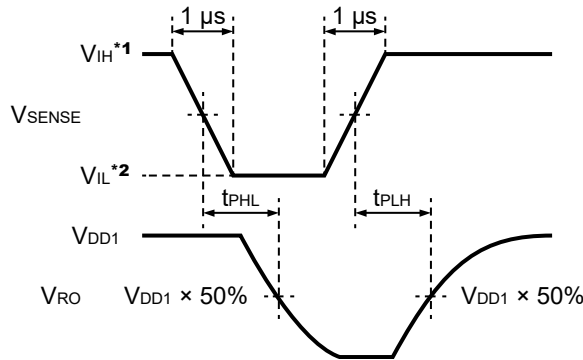
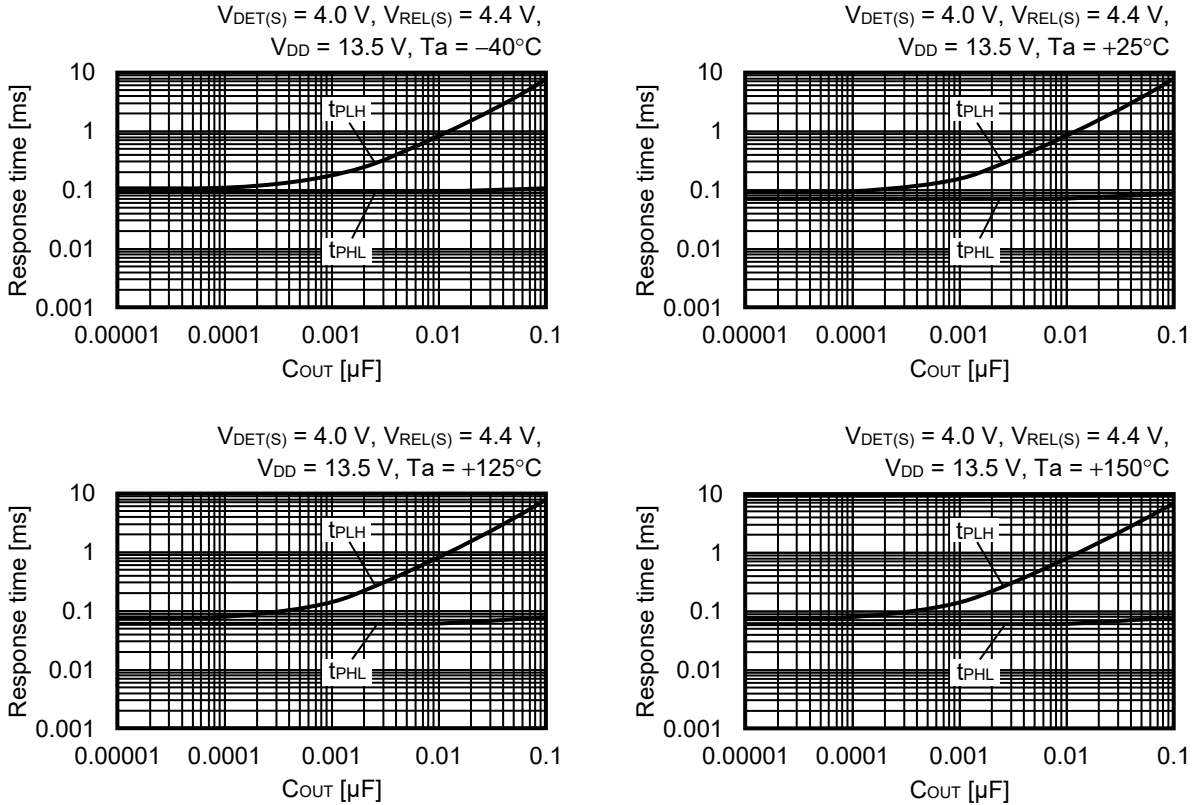

- *1. $V_{\text{IH}} = V_{\text{DET(S)}} + 1.0\text{ V}$
- *2. $V_{\text{IL}} = V_{\text{DET(S)}} - 1.0\text{ V}$

Figure 26 Test Condition of Response Time

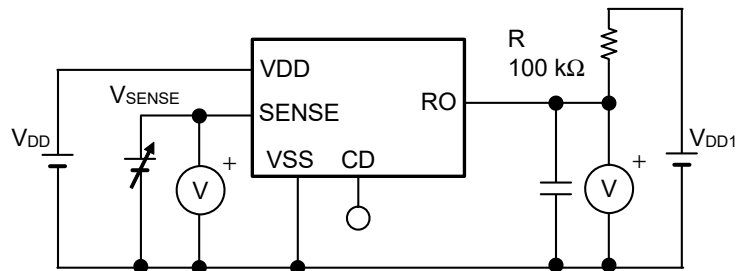

Figure 27 Test Circuit of Response Time

Caution The above connection diagram and constants will not guarantee successful operation. Perform thorough evaluation including the temperature characteristics with an actual application to set the constants.

2. Supply voltage divider block

2.1 Output voltage of supply voltage divider block (V_{PMOUT}) vs. Load current (I_{PMOUT})

2.1.1 $V_{PMOUT} = V_{SENSE}/6$

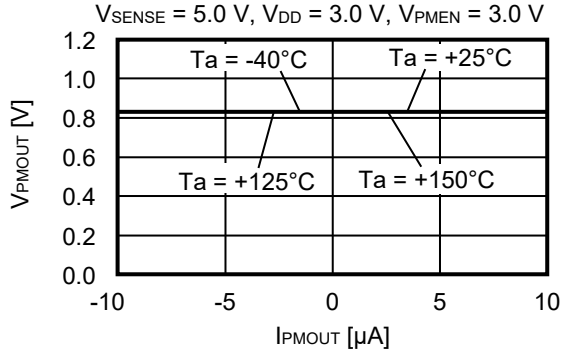

2.1.2 $V_{PMOUT} = V_{SENSE}/14$

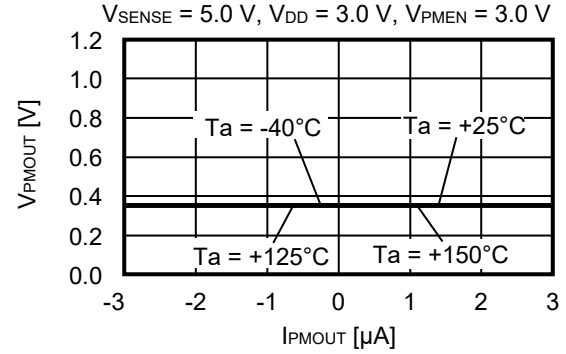

2.2 Output voltage of supply voltage divider block (V_{PMOUT}) vs. Temperature (T_a)

2.2.1 $V_{PMOUT} = V_{SENSE}/6$

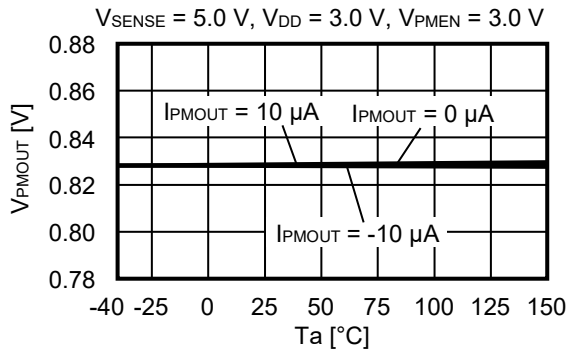

2.2.2 $V_{PMOUT} = V_{SENSE}/14$

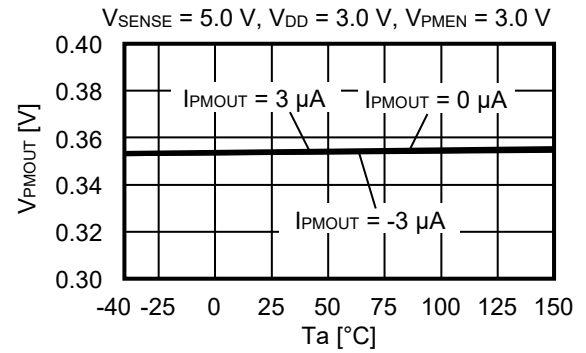

2.3 Output voltage of supply voltage divider block (V_{PMOUT}) vs. SENSE pin voltage (V_{SENSE})

2.3.1 $V_{PMOUT} = V_{SENSE}/6$

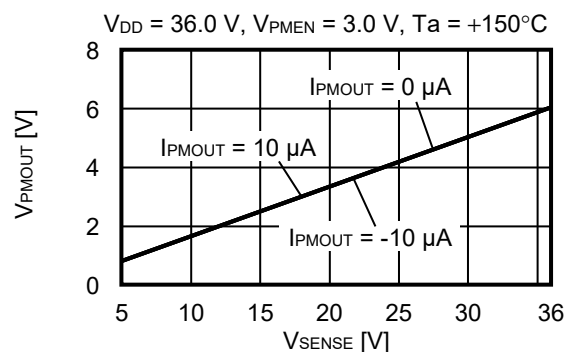
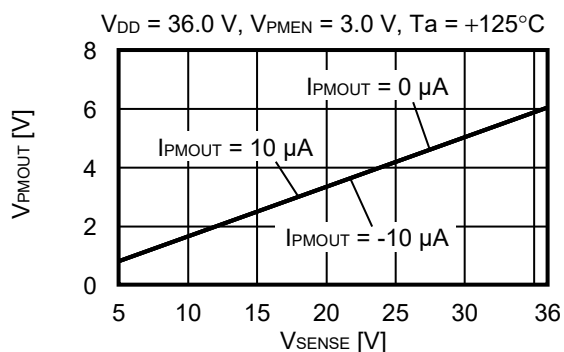
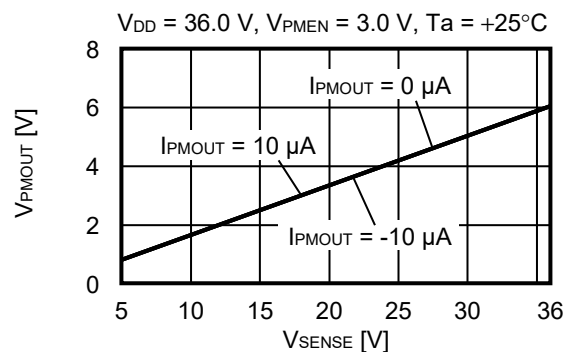
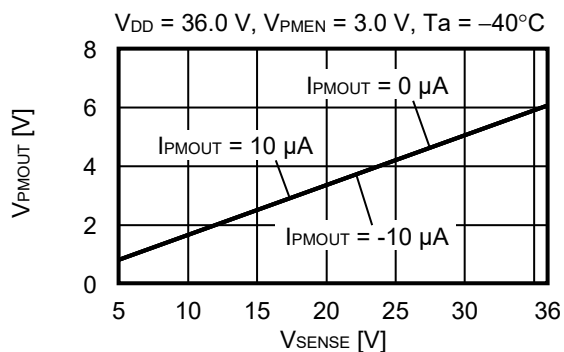

2.3.2 $V_{PMOUT} = V_{SENSE}/14$

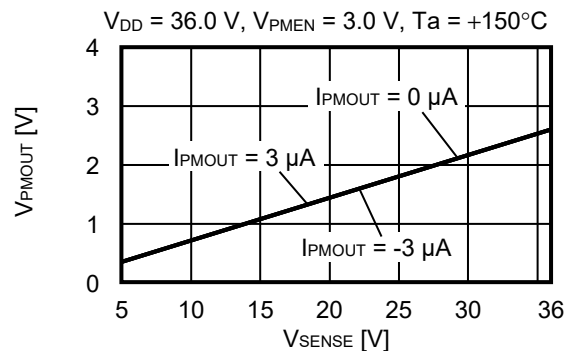
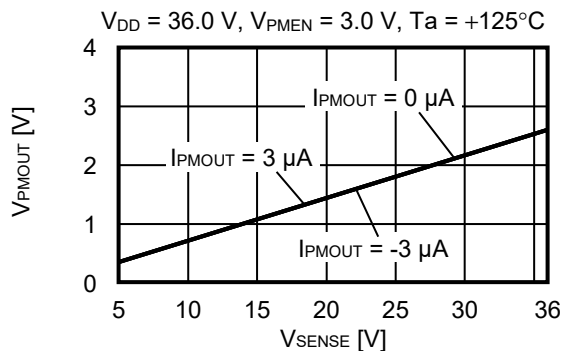
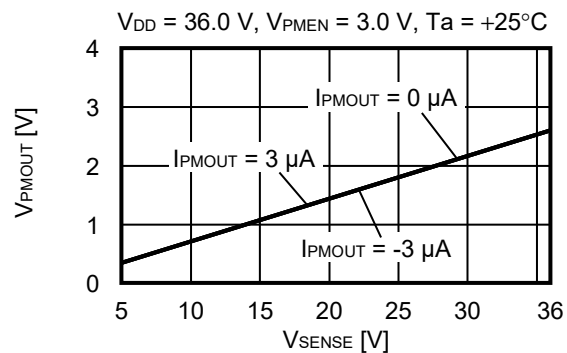
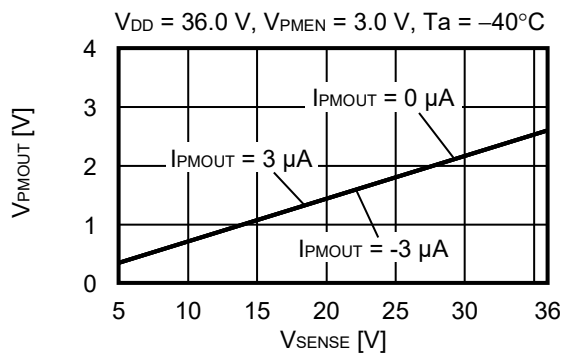

3. Overall

3.1 Current consumption (I_{SS1}) vs. Temperature (T_a)

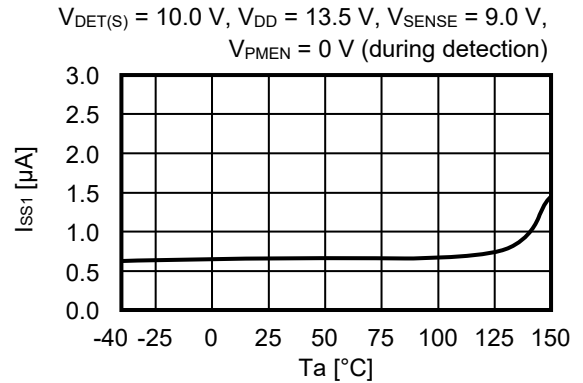
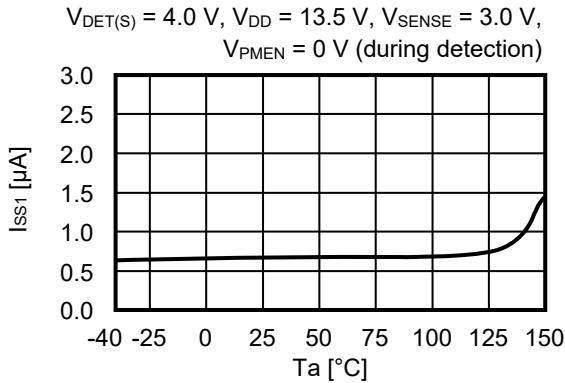
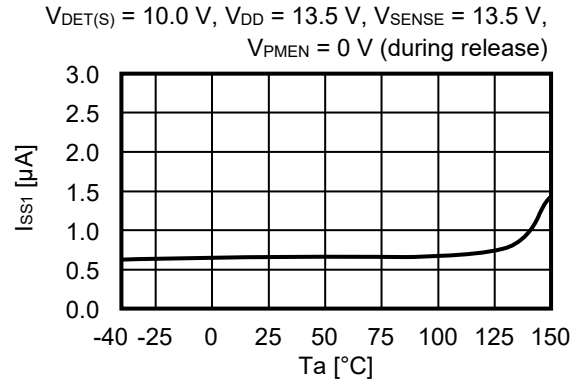
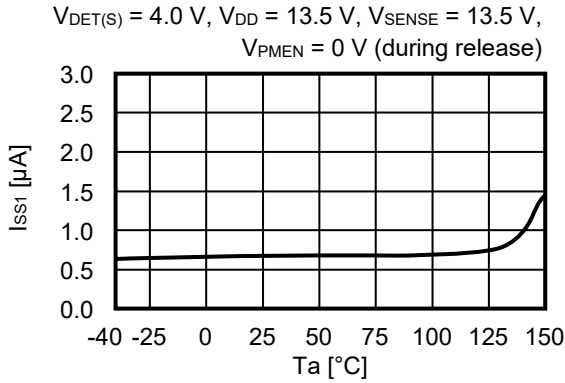

3.2 Current consumption (I_{SS1}) vs. Power supply voltage (V_{DD}) (No load)

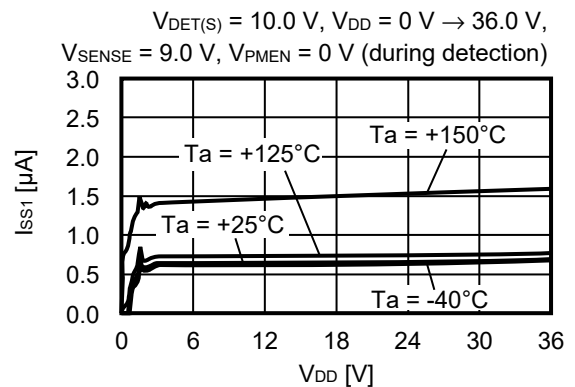
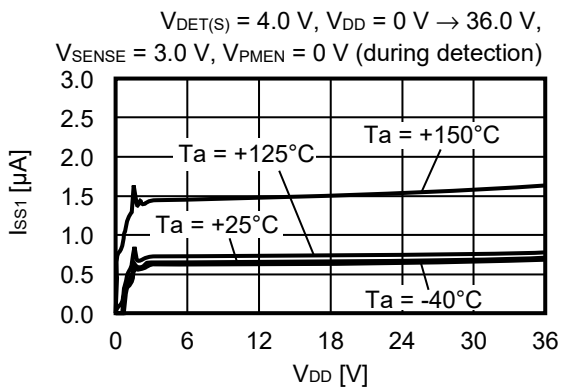
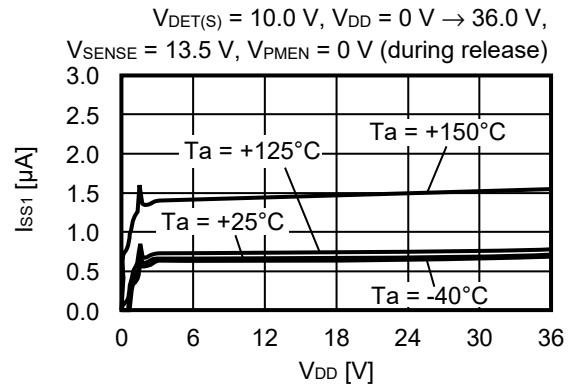
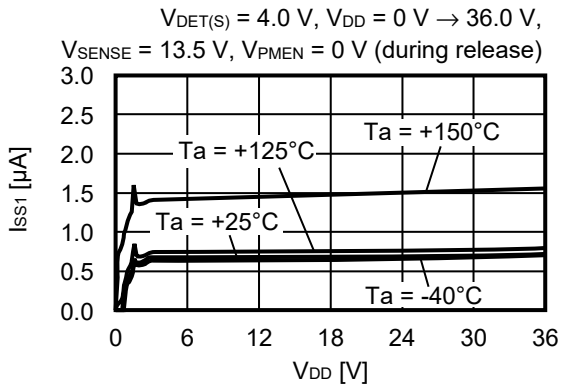

3.3 Current consumption (I_{SSP1}) vs. Temperature (T_a)
 (No load, during supply voltage divided output operates)

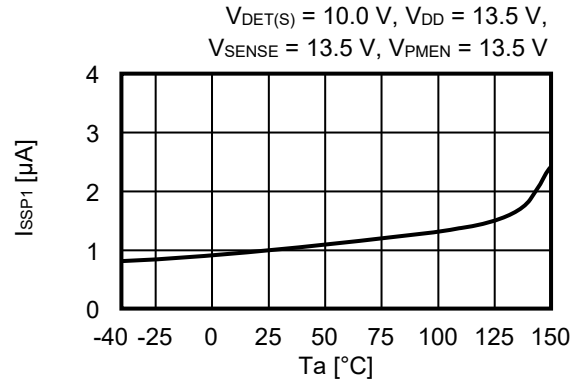
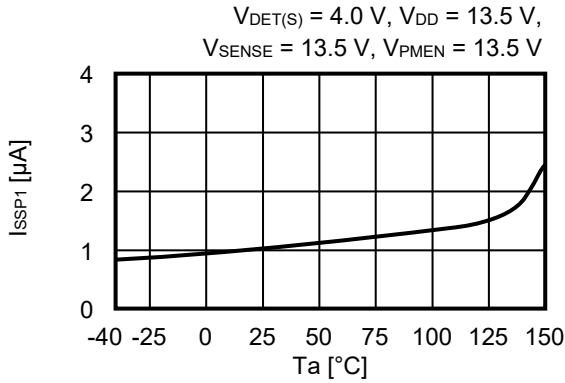

3.4 Current consumption (I_{SSP1}) vs. Power supply voltage (V_{DD})
 (No load, during supply voltage divided output operates)

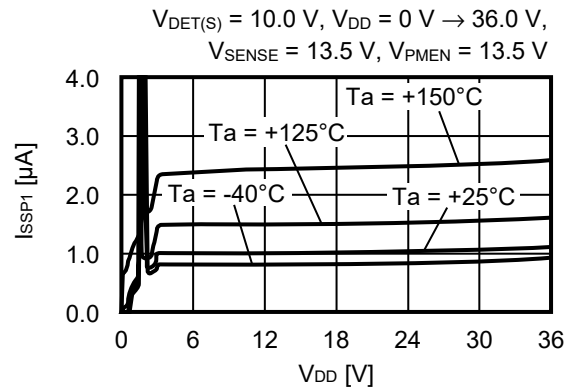
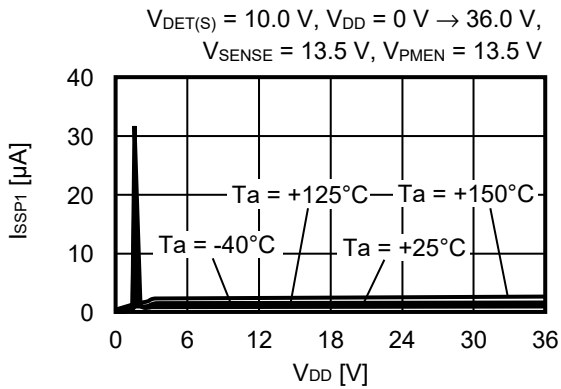
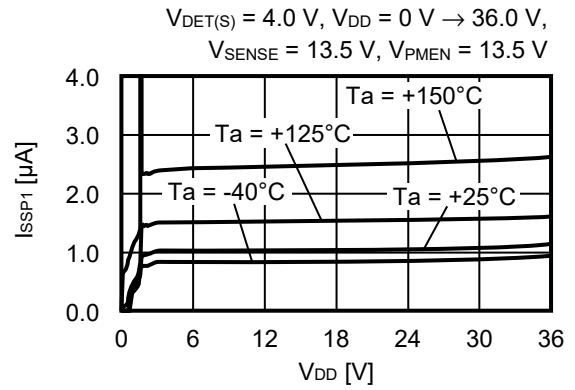
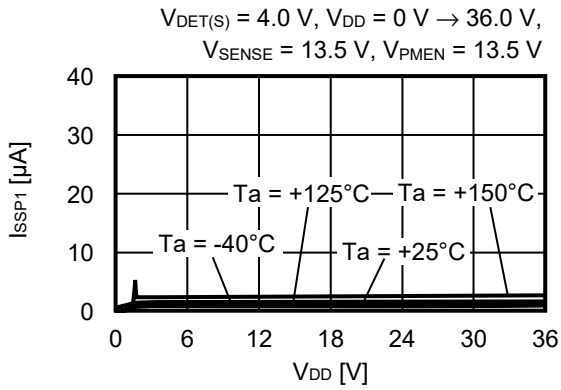

■ Reference Data

1. Detection response time (t_{RESET}) vs. Temperature (T_a)

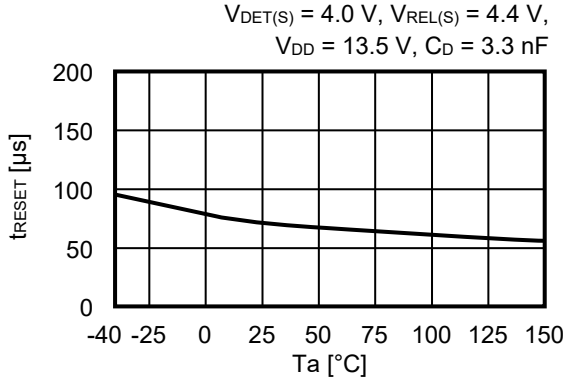

2. Detection response time (t_{RESET}) vs. Power supply voltage (V_{DD})

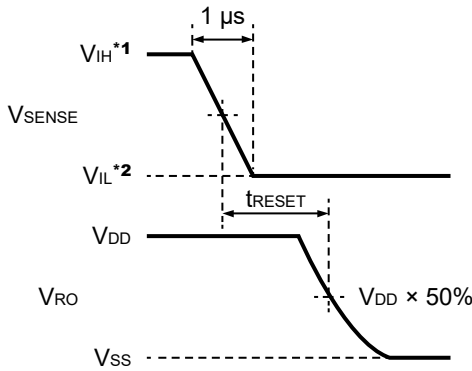
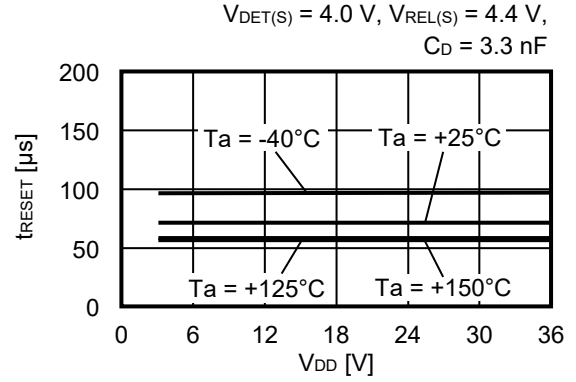

- *1. $V_{IH} = V_{DET(S)} + 1.0\text{ V}$
- *2. $V_{IL} = V_{DET(S)} - 1.0\text{ V}$

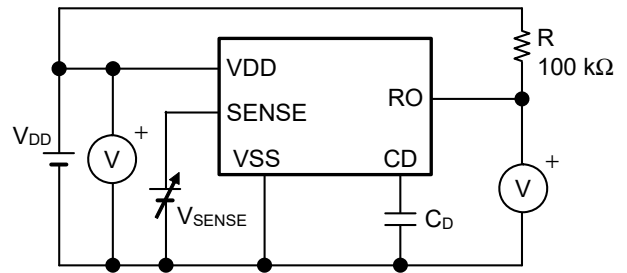
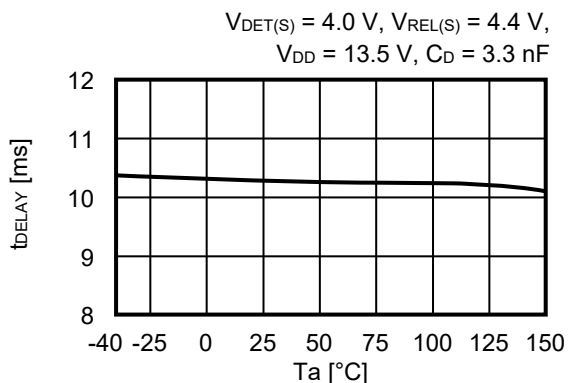

Figure 28 Test Condition of Detection Response Time

Figure 29 Test Circuit of Detection Response Time

Caution The above connection diagram and constants will not guarantee successful operation. Perform thorough evaluation including the temperature characteristics with an actual application to set the constants.

3. Release delay time (t_{DELAY}) vs. Temperature (T_a)



4. Release delay time (t_{DELAY}) vs. Power supply voltage (V_{DD})

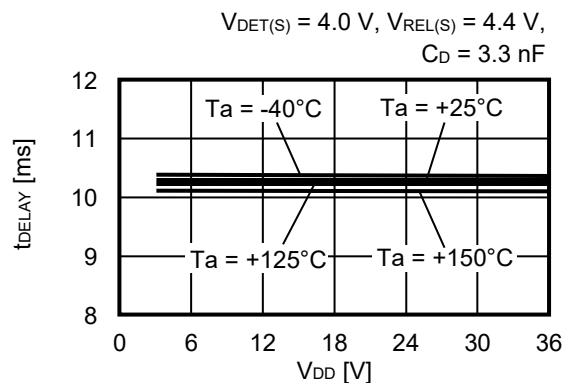

5. Release delay time (t_{DELAY}) vs. CD pin capacitance (C_D) (Without output pin capacitance)

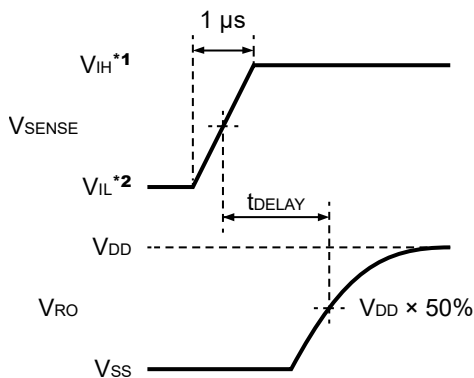
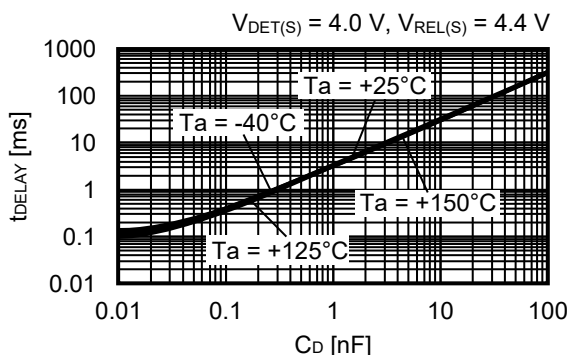

*1. $V_{IH} = V_{REL(S)} + 1.0\text{ V}$

*2. $V_{IL} = V_{REL(S)} - 1.0\text{ V}$

Figure 30 Test Condition of Release Delay Time

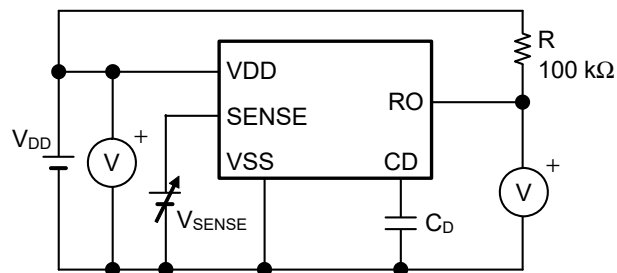

Figure 31 Test Circuit of Release Delay Time

Caution The above connection diagram and constants will not guarantee successful operation. Perform thorough evaluation including the temperature characteristics with an actual application to set the constants.

6. Transient response characteristics of PMEN pin (Ta = +25°C)

6.1 $V_{PMOUT} = V_{SENSE}/6$

$V_{DD} = V_{SENSE} = 5.0\text{ V}$, $C_{PM} = 0.22\ \mu\text{F}$,
 $V_{PMEN} = 0\text{ V} \leftrightarrow 5.0\text{ V}$ ($t_r = t_f = 1.0\ \mu\text{s}$)

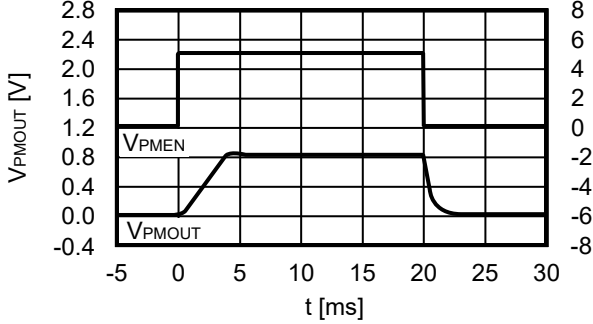

$V_{DD} = V_{SENSE} = 18.0\text{ V}$, $C_{PM} = 0.22\ \mu\text{F}$,
 $V_{PMEN} = 0\text{ V} \leftrightarrow 18.0\text{ V}$ ($t_r = t_f = 1.0\ \mu\text{s}$)

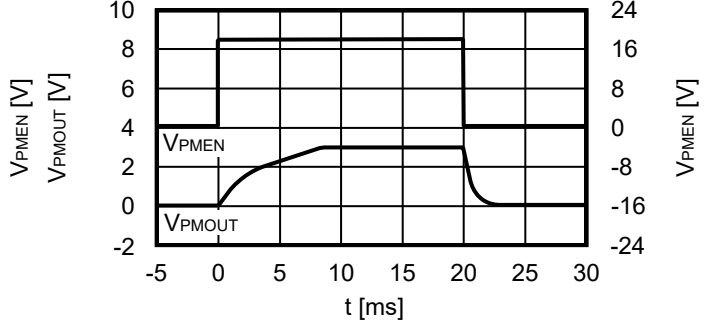

6.2 $V_{PMOUT} = V_{SENSE}/14$

$V_{DD} = V_{SENSE} = 5.0\text{ V}$, $C_{PM} = 0.22\ \mu\text{F}$,
 $V_{PMEN} = 0\text{ V} \leftrightarrow 5.0\text{ V}$ ($t_r = t_f = 1.0\ \mu\text{s}$)

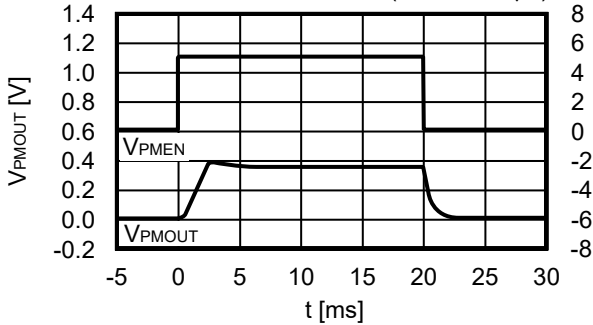

$V_{DD} = V_{SENSE} = 18.0\text{ V}$, $C_{PM} = 0.22\ \mu\text{F}$,
 $V_{PMEN} = 0\text{ V} \leftrightarrow 18.0\text{ V}$ ($t_r = t_f = 1.0\ \mu\text{s}$)

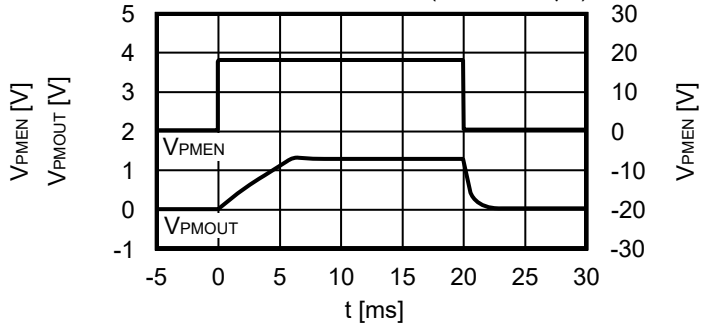

7. Example of equivalent series resistance vs. Load current characteristics (Ta = -40°C to +150°C)

7.1 $V_{PMOUT} = V_{SENSE}/6, V_{SENSE}/8, V_{SENSE}/12$

$C_{PM} = 0.1\ \mu\text{F}$

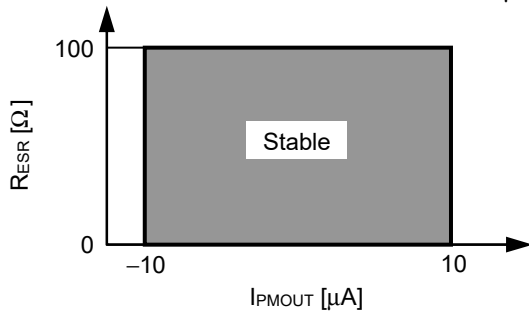

Figure 32

7.2 $V_{PMOUT} = V_{SENSE}/14$

$C_{PM} = 0.1\ \mu\text{F}$

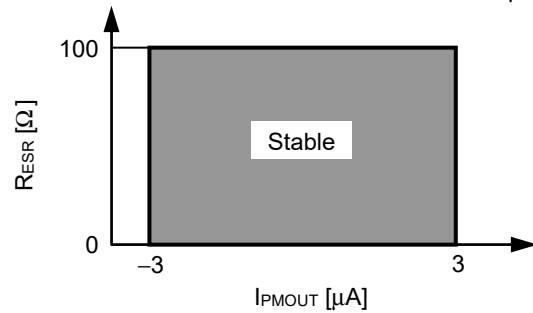
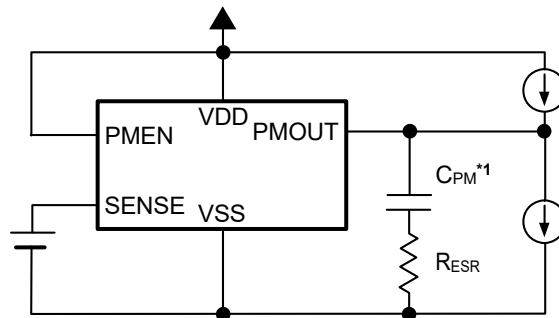

Figure 33



*1. CPM: TDK Corporation CGA4J2X8R1H104K

Figure 34

■ Power Dissipation

HTMSOP-8

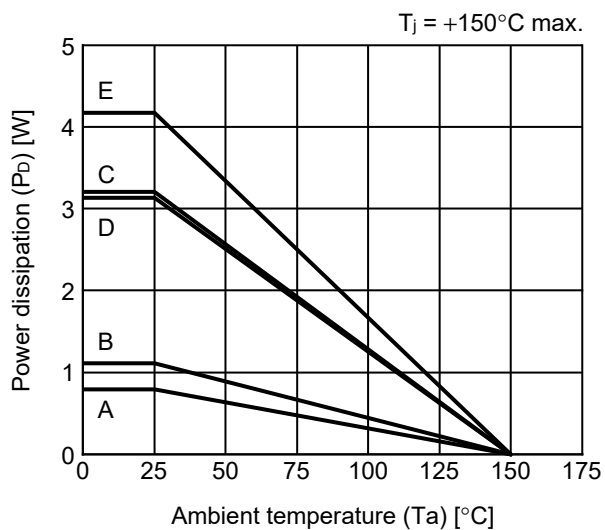

Board	Power Dissipation (P _D)
A	0.79 W
B	1.11 W
C	3.21 W
D	3.13 W
E	4.17 W

HSNT-8(2030)

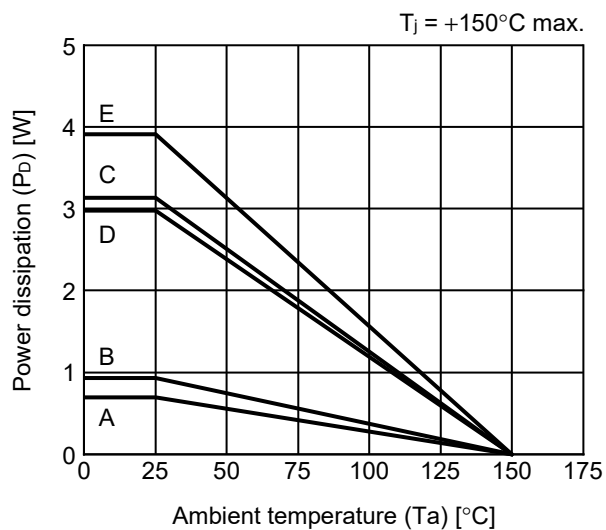

Board	Power Dissipation (P _D)
A	0.69 W
B	0.93 W
C	3.13 W
D	2.98 W
E	3.91 W

HTMSOP-8 Test Board

 IC Mount Area

(1) Board A

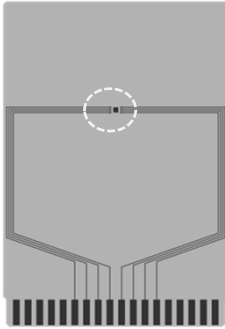

Item	Specification	
Size [mm]	114.3 x 76.2 x t1.6	
Material	FR-4	
Number of copper foil layer	2	
Copper foil layer [mm]	1	Land pattern and wiring for testing: t0.070
	2	-
	3	-
	4	74.2 x 74.2 x t0.070
Thermal via	-	

(2) Board B

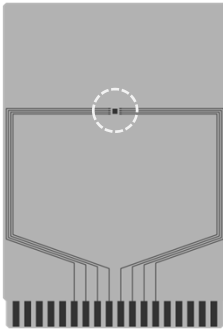

Item	Specification	
Size [mm]	114.3 x 76.2 x t1.6	
Material	FR-4	
Number of copper foil layer	4	
Copper foil layer [mm]	1	Land pattern and wiring for testing: t0.070
	2	74.2 x 74.2 x t0.035
	3	74.2 x 74.2 x t0.035
	4	74.2 x 74.2 x t0.070
Thermal via	-	

(3) Board C

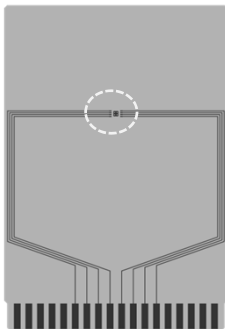

Item	Specification	
Size [mm]	114.3 x 76.2 x t1.6	
Material	FR-4	
Number of copper foil layer	4	
Copper foil layer [mm]	1	Land pattern and wiring for testing: t0.070
	2	74.2 x 74.2 x t0.035
	3	74.2 x 74.2 x t0.035
	4	74.2 x 74.2 x t0.070
Thermal via	Number: 4 Diameter: 0.3 mm	



enlarged view

No. HTMSOP8-A-Board-SD-1.0

HTMSOP-8 Test Board

 IC Mount Area

(4) Board D

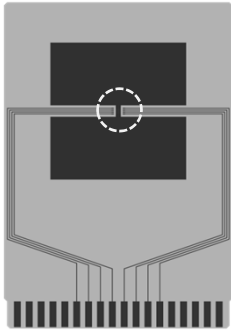

Item	Specification	
Size [mm]	114.3 x 76.2 x t1.6	
Material	FR-4	
Number of copper foil layer	4	
Copper foil layer [mm]	1	Pattern for heat radiation: 2000mm ² t0.070
	2	74.2 x 74.2 x t0.035
	3	74.2 x 74.2 x t0.035
	4	74.2 x 74.2 x t0.070
Thermal via	-	



enlarged view

(5) Board E

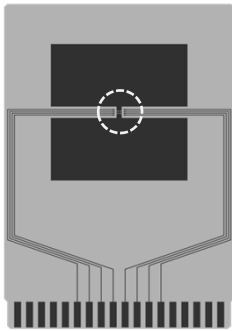

Item	Specification	
Size [mm]	114.3 x 76.2 x t1.6	
Material	FR-4	
Number of copper foil layer	4	
Copper foil layer [mm]	1	Pattern for heat radiation: 2000mm ² t0.070
	2	74.2 x 74.2 x t0.035
	3	74.2 x 74.2 x t0.035
	4	74.2 x 74.2 x t0.070
Thermal via	Number: 4 Diameter: 0.3 mm	



enlarged view

No. HTMSOP8-A-Board-SD-1.0

HSNT-8(2030) Test Board

 IC Mount Area

(1) Board A

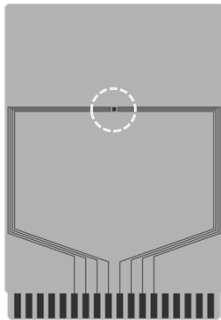

Item		Specification
Size [mm]		114.3 x 76.2 x t1.6
Material		FR-4
Number of copper foil layer		2
Copper foil layer [mm]	1	Land pattern and wiring for testing: t0.070
	2	-
	3	-
	4	74.2 x 74.2 x t0.070
Thermal via		-

(2) Board B

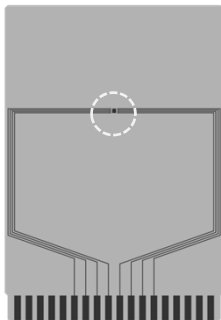

Item		Specification
Size [mm]		114.3 x 76.2 x t1.6
Material		FR-4
Number of copper foil layer		4
Copper foil layer [mm]	1	Land pattern and wiring for testing: t0.070
	2	74.2 x 74.2 x t0.035
	3	74.2 x 74.2 x t0.035
	4	74.2 x 74.2 x t0.070
Thermal via		-

(3) Board C

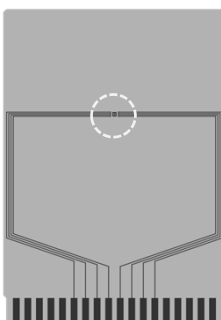

Item		Specification
Size [mm]		114.3 x 76.2 x t1.6
Material		FR-4
Number of copper foil layer		4
Copper foil layer [mm]	1	Land pattern and wiring for testing: t0.070
	2	74.2 x 74.2 x t0.035
	3	74.2 x 74.2 x t0.035
	4	74.2 x 74.2 x t0.070
Thermal via		Number: 4 Diameter: 0.3 mm



enlarged view

No. HSNT8-A-Board-SD-2.0

HSNT-8(2030) Test Board

 IC Mount Area

(4) Board D

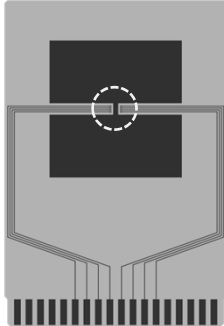

Item	Specification	
Size [mm]	114.3 x 76.2 x t1.6	
Material	FR-4	
Number of copper foil layer	4	
Copper foil layer [mm]	1	Pattern for heat radiation: 2000mm ² t0.070
	2	74.2 x 74.2 x t0.035
	3	74.2 x 74.2 x t0.035
	4	74.2 x 74.2 x t0.070
Thermal via	-	



enlarged view

(5) Board E

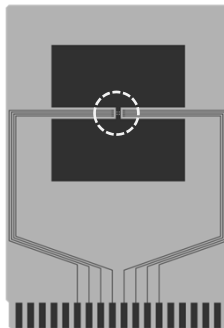

Item	Specification	
Size [mm]	114.3 x 76.2 x t1.6	
Material	FR-4	
Number of copper foil layer	4	
Copper foil layer [mm]	1	Pattern for heat radiation: 2000mm ² t0.070
	2	74.2 x 74.2 x t0.035
	3	74.2 x 74.2 x t0.035
	4	74.2 x 74.2 x t0.070
Thermal via	Number: 4 Diameter: 0.3 mm	



enlarged view

No. HSNT8-A-Board-SD-2.0

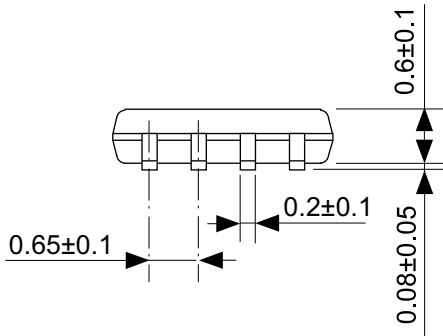
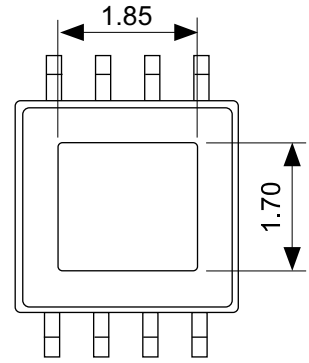
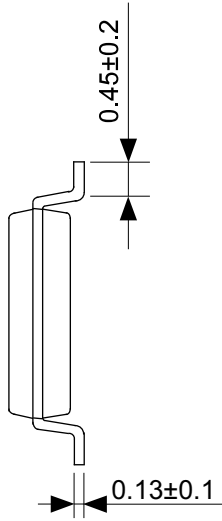
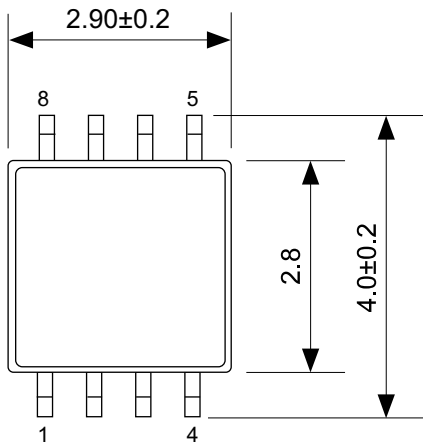

No. FP008-A-P-SD-2.0

TITLE	HTMSOP8-A-PKG Dimensions
No.	FP008-A-P-SD-2.0
ANGLE	
UNIT	mm
ABLIC Inc.	

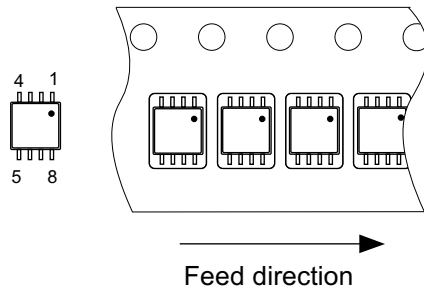
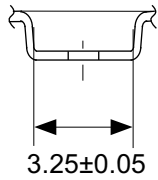
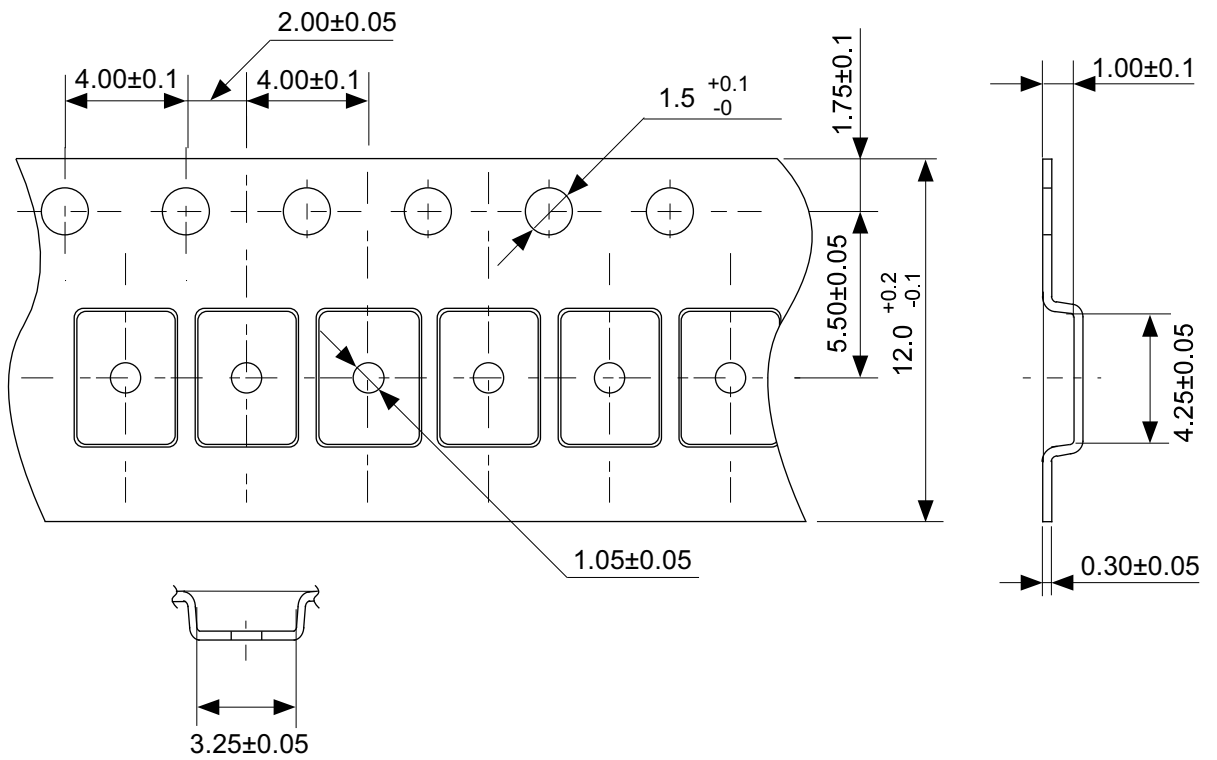

No. FP008-A-C-SD-1.0

TITLE	HTMSOP8-A-Carrier Tape
No.	FP008-A-C-SD-1.0
ANGLE	
UNIT	mm
ABLIC Inc.	

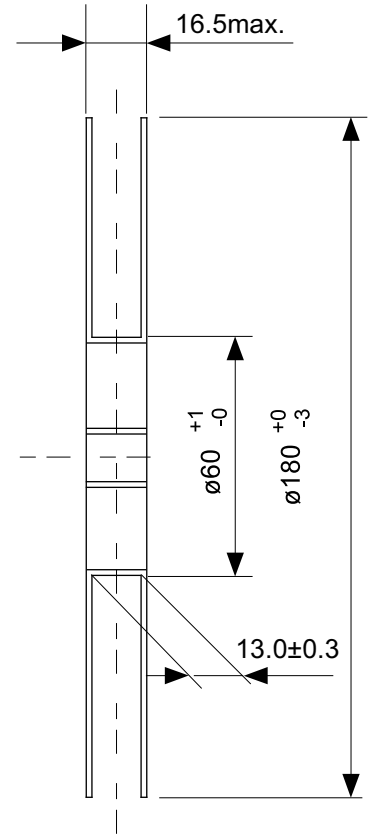
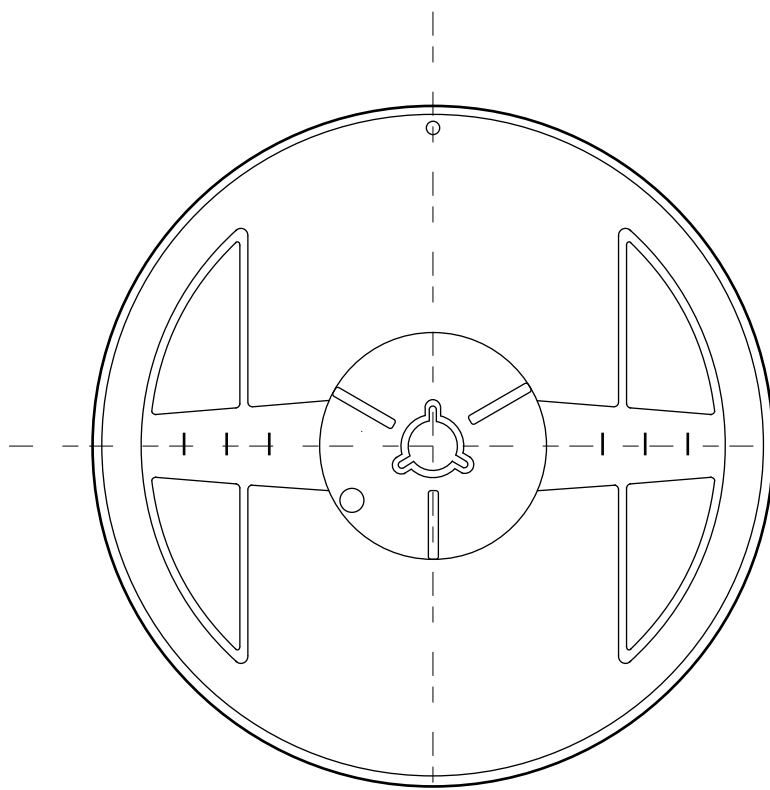

Enlarged drawing in the central part

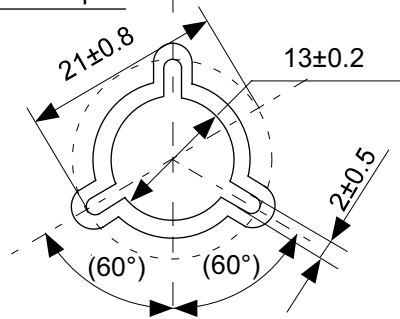

No. FP008-A-R-SD-1.0

TITLE	HTMSOP8-A-Reel		
No.	FP008-A-R-SD-1.0		
ANGLE		QTY.	4,000
UNIT	mm		
ABLIC Inc.			

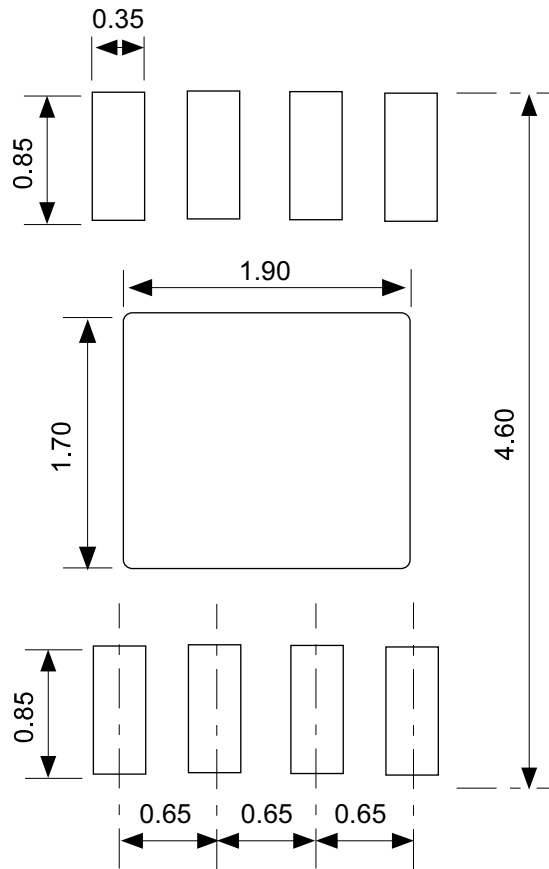

No. FP008-A-L-SD-2.0

TITLE	HTMSOP8-A -Land Recommendation
No.	FP008-A-L-SD-2.0
ANGLE	
UNIT	mm
ABLIC Inc.	

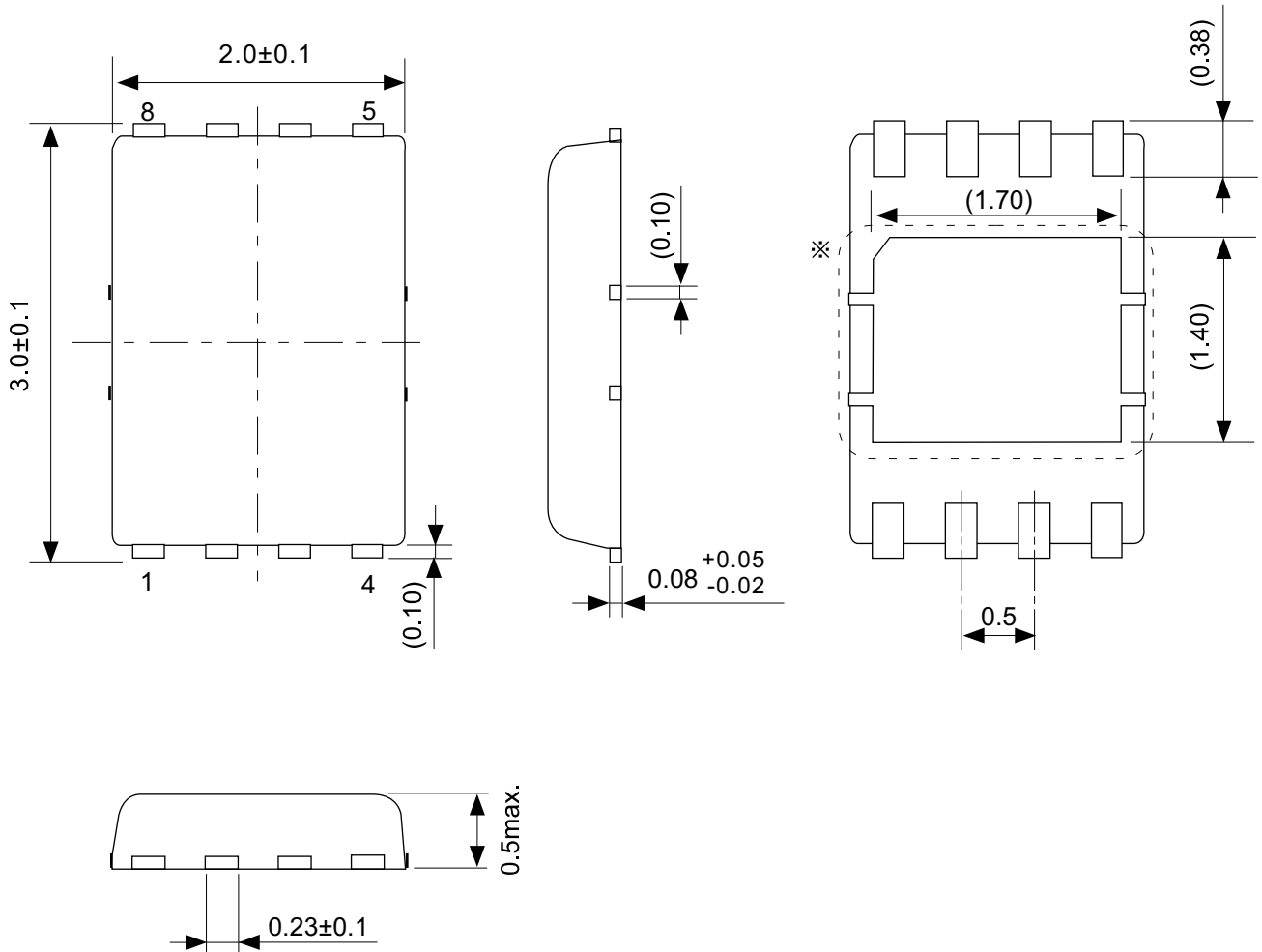

\ast The heat sink of back side has different electric potential depending on the product.
 Confirm specifications of each product.
 Do not use it as the function of electrode.

No. PP008-A-P-SD-2.0

TITLE	HSNT-8-A-PKG Dimensions
No.	PP008-A-P-SD-2.0
ANGLE	
UNIT	mm
ABLIC Inc.	

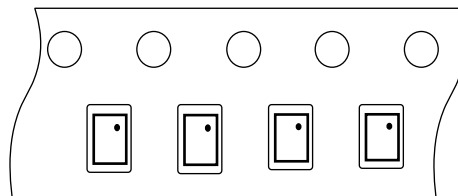
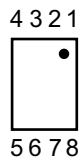
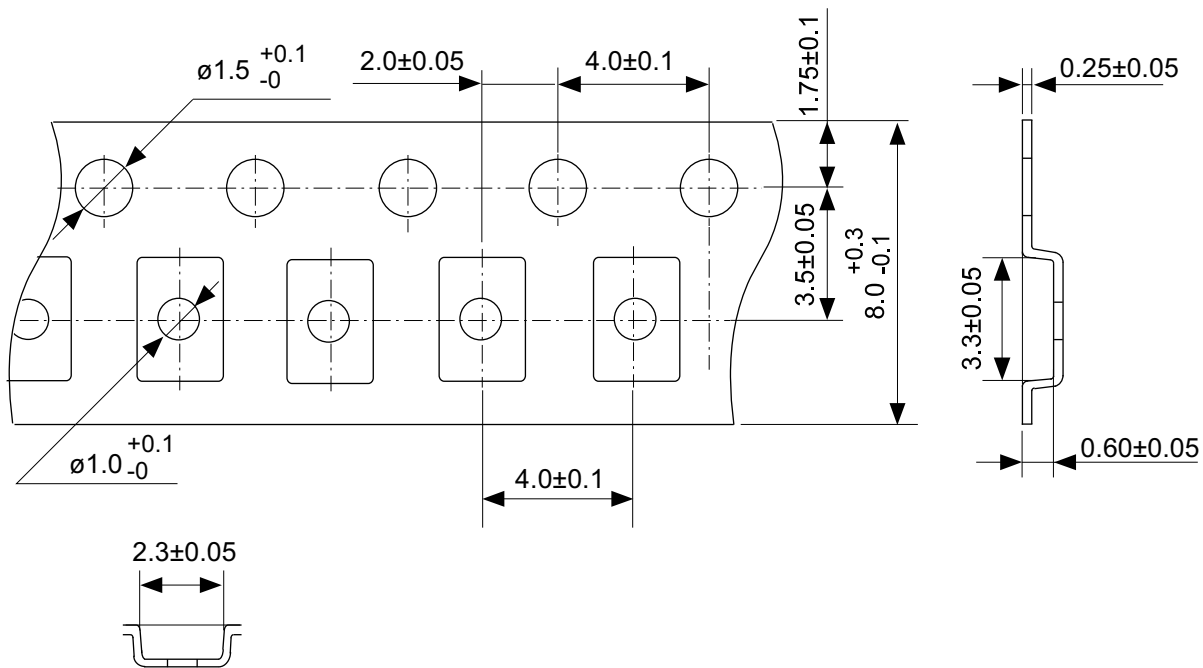

No. PP008-A-C-SD-1.0

TITLE	HSNT-8-A-Carrier Tape
No.	PP008-A-C-SD-1.0
ANGLE	
UNIT	mm
ABLIC Inc.	

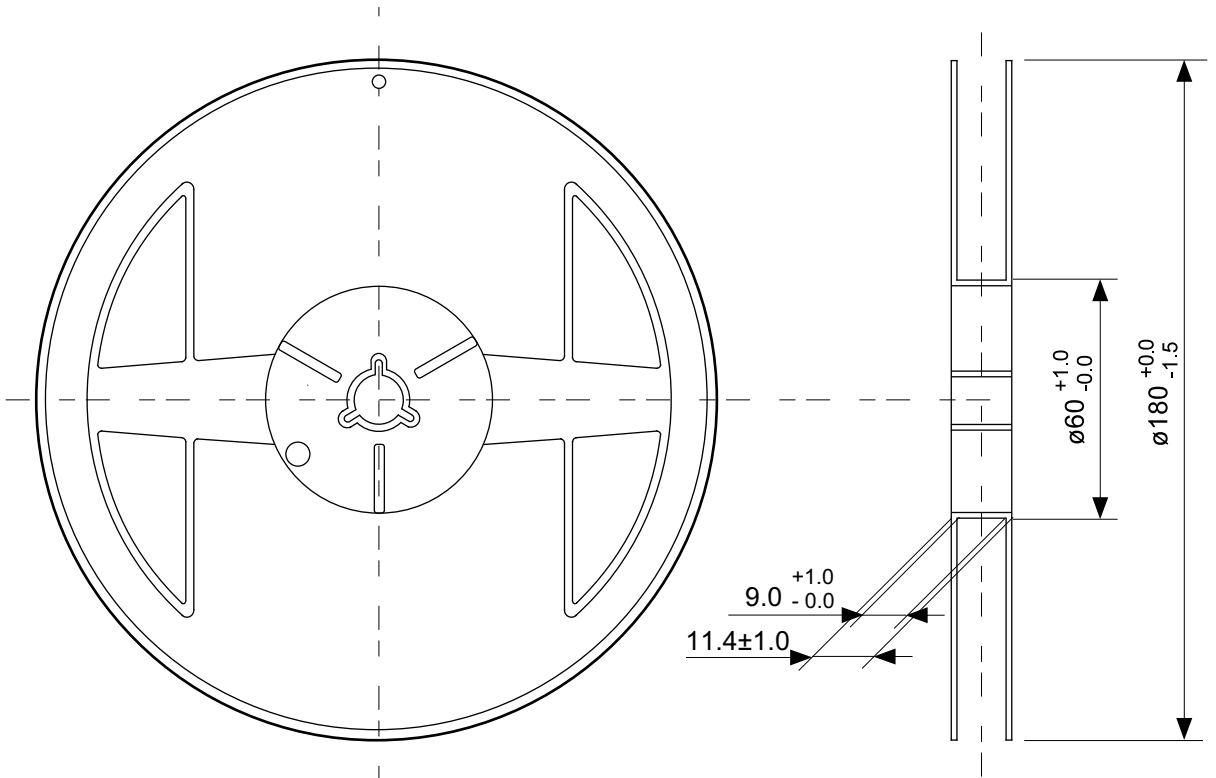

Enlarged drawing in the central part

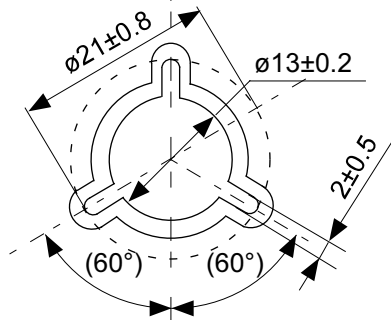

No. PP008-A-R-SD-1.0

TITLE	HSNT-8-A-Reel		
No.	PP008-A-R-SD-1.0		
ANGLE		QTY.	5,000
UNIT	mm		
ABLIC Inc.			

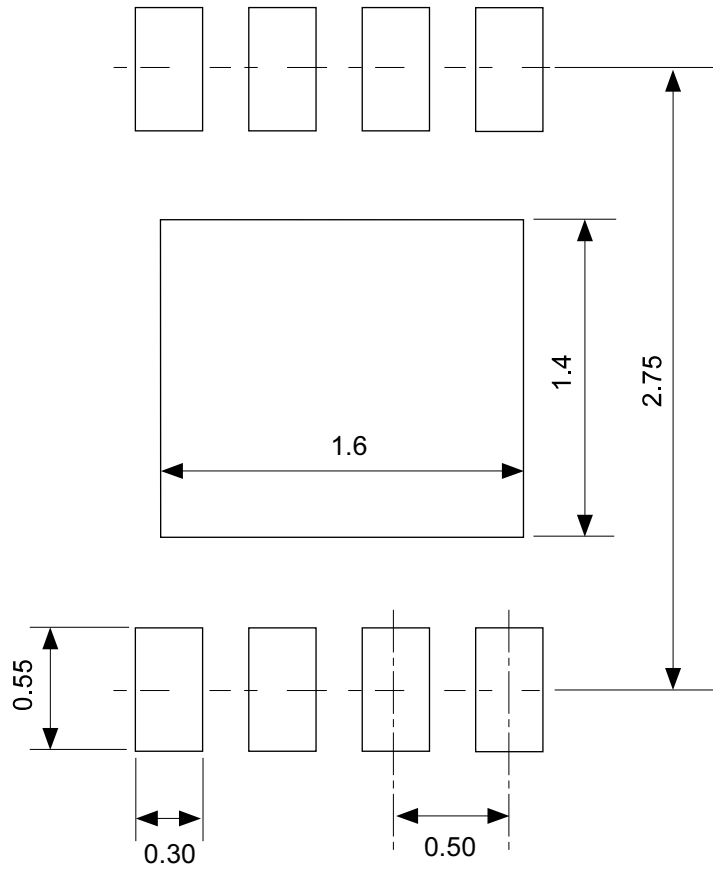

No. PP008-A-L-SD-1.0

TITLE	HSNT-8-A -Land Recommendation
No.	PP008-A-L-SD-1.0
ANGLE	
UNIT	mm
ABLIC Inc.	

Disclaimers (Handling Precautions)

1. All the information described herein (product data, specifications, figures, tables, programs, algorithms and application circuit examples, etc.) is current as of publishing date of this document and is subject to change without notice.
2. The circuit examples and the usages described herein are for reference only, and do not guarantee the success of any specific mass-production design.
ABLIC Inc. is not liable for any losses, damages, claims or demands caused by the reasons other than the products described herein (hereinafter "the products") or infringement of third-party intellectual property right and any other right due to the use of the information described herein.
3. ABLIC Inc. is not liable for any losses, damages, claims or demands caused by the incorrect information described herein.
4. Be careful to use the products within their ranges described herein. Pay special attention for use to the absolute maximum ratings, operation voltage range and electrical characteristics, etc.
ABLIC Inc. is not liable for any losses, damages, claims or demands caused by failures and / or accidents, etc. due to the use of the products outside their specified ranges.
5. Before using the products, confirm their applications, and the laws and regulations of the region or country where they are used and verify suitability, safety and other factors for the intended use.
6. When exporting the products, comply with the Foreign Exchange and Foreign Trade Act and all other export-related laws, and follow the required procedures.
7. The products are strictly prohibited from using, providing or exporting for the purposes of the development of weapons of mass destruction or military use. ABLIC Inc. is not liable for any losses, damages, claims or demands caused by any provision or export to the person or entity who intends to develop, manufacture, use or store nuclear, biological or chemical weapons or missiles, or use any other military purposes.
8. The products are not designed to be used as part of any device or equipment that may affect the human body, human life, or assets (such as medical equipment, disaster prevention systems, security systems, combustion control systems, infrastructure control systems, vehicle equipment, traffic systems, in-vehicle equipment, aviation equipment, aerospace equipment, and nuclear-related equipment), excluding when specified for in-vehicle use or other uses by ABLIC, Inc. Do not apply the products to the above listed devices and equipments.
ABLIC Inc. is not liable for any losses, damages, claims or demands caused by unauthorized or unspecified use of the products.
9. In general, semiconductor products may fail or malfunction with some probability. The user of the products should therefore take responsibility to give thorough consideration to safety design including redundancy, fire spread prevention measures, and malfunction prevention to prevent accidents causing injury or death, fires and social damage, etc. that may ensue from the products' failure or malfunction.
The entire system in which the products are used must be sufficiently evaluated and judged whether the products are allowed to apply for the system on customer's own responsibility.
10. The products are not designed to be radiation-proof. The necessary radiation measures should be taken in the product design by the customer depending on the intended use.
11. The products do not affect human health under normal use. However, they contain chemical substances and heavy metals and should therefore not be put in the mouth. The fracture surfaces of wafers and chips may be sharp. Be careful when handling these with the bare hands to prevent injuries, etc.
12. When disposing of the products, comply with the laws and ordinances of the country or region where they are used.
13. The information described herein contains copyright information and know-how of ABLIC Inc. The information described herein does not convey any license under any intellectual property rights or any other rights belonging to ABLIC Inc. or a third party. Reproduction or copying of the information from this document or any part of this document described herein for the purpose of disclosing it to a third-party is strictly prohibited without the express permission of ABLIC Inc.
14. For more details on the information described herein or any other questions, please contact ABLIC Inc.'s sales representative.
15. This Disclaimers have been delivered in a text using the Japanese language, which text, despite any translations into the English language and the Chinese language, shall be controlling.

2.4-2019.07