

This IC, developed using CMOS technology, is a high-accuracy voltage detector. The detection voltage and release voltage are fixed internally with an accuracy of  $\pm 2.0\%$ .

Apart from the power supply pin, the detection voltage input pin (SENSE pin) is also prepared, so the output is stable even if the SENSE pin voltage ( $V_{\text{SENSE}}$ ) falls to 0 V. The SENSE pin also has a built-in reverse connection protection circuit that reduces current in the SENSE pin during a reverse connection.

The release signal can be delayed by setting a capacitor externally, and the release delay time accuracy is  $\pm 20\%$  ( $C_D = 3.3 \text{ nF}$ ). The output form is Nch open-drain output.

ABLIC Inc. offers FIT rate calculated based on actual customer usage conditions in order to support customer functional safety design.

For more information regarding our FIT rate calculation, contact our sales representatives.

**Caution This product can be used in vehicle equipment and in-vehicle equipment. Before using the product for these purposes, it is imperative to contact our sales representatives.**

## ■ Features

- Detection voltage: 16.0 V to 18.0 V (0.1 V step)
- Detection voltage accuracy:  $\pm 2.0\%$
- Hysteresis width selectable from "Available" / "Unavailable": "Available": 5.0%, 10.0%  
"Unavailable": 0%
- Release delay time accuracy:  $\pm 20\%$  ( $C_D = 3.3 \text{ nF}$ )
- Current consumption: 0.6  $\mu\text{A}$  typ.
- Output form: Nch open-drain output
- Built-in reverse connection protection circuit: Reduces current in the SENSE pin during a reverse connection.
- Operation voltage range: 3.0 V to 36.0 V
- Operation temperature range:  $T_a = -40^\circ\text{C}$  to  $+150^\circ\text{C}$
- Lead-free (Sn 100%), halogen-free
- AEC-Q100 in process\*1

\*1. Contact our sales representatives for details.

## ■ Applications

- Automotive battery voltage detection
- For automotive use (engine, transmission, suspension, ABS, related-devices for EV / HEV / PHEV, etc.)

## ■ Packages

- HTMSOP-8
- HSNT-8(2030)
- SOT-23-5

■ **Block Diagrams**

1. **S-19115 Series L type**

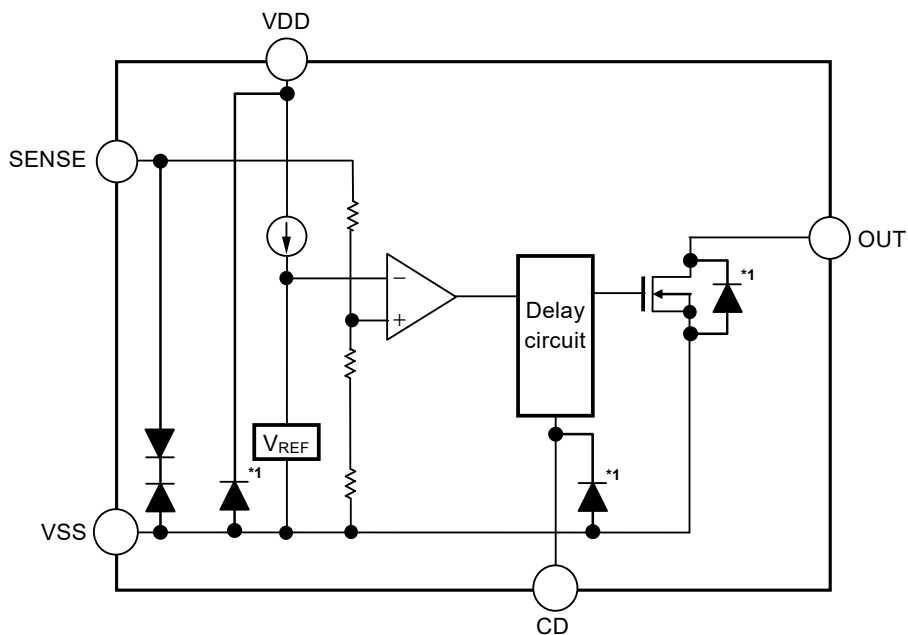

\*1. Parasitic diode

Figure 1

Product Type	Hysteresis Width	Output Form	Output Logic
L type	0%	Nch open-drain output	Active "L"

2. S-19115 Series M / N type

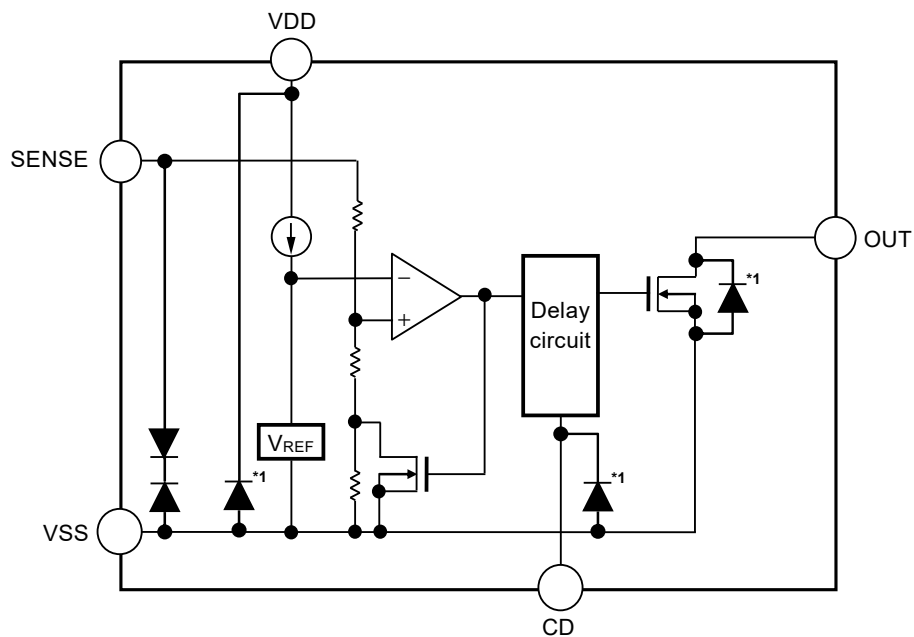

\*1. Parasitic diode

Figure 2

Product Type	Hysteresis Width	Output Form	Output Logic
M type	5.0%	Nch open-drain output	Active "L"
N type	10.0%	Nch open-drain output	Active "L"

■ **AEC-Q100 in Process**

Contact our sales representatives for details of AEC-Q100 reliability specification.

■ **Product Name Structure**

1. **Product name**

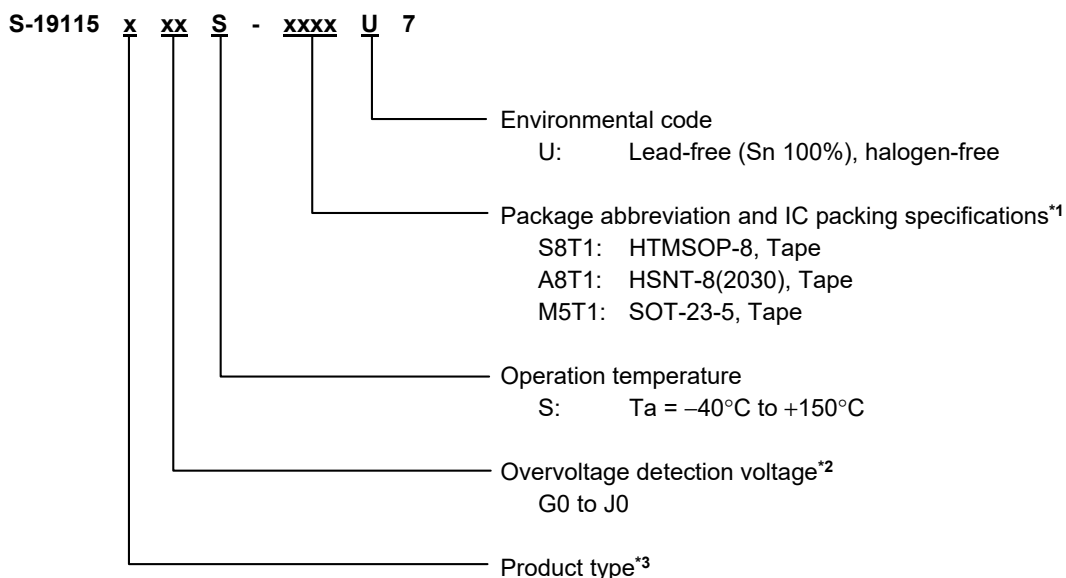

- \*1. Refer to the tape drawing.
- \*2. Refer to **Table 1** for the overvoltage detection voltage.
- \*3. Refer to "**2. Function list of product types**".

**Table 1**

Overvoltage Detection Voltage	Symbol
16.0 V	G0
16.1 V	G1
16.2 V	G2
16.3 V	G3
16.4 V	G4
16.5 V	G5
16.6 V	G6

Overvoltage Detection Voltage	Symbol
16.7 V	G7
16.8 V	G8
16.9 V	G9
17.0 V	H0
17.1 V	H1
17.2 V	H2
17.3 V	H3

Overvoltage Detection Voltage	Symbol
17.4 V	H4
17.5 V	H5
17.6 V	H6
17.7 V	H7
17.8 V	H8
17.9 V	H9
18.0 V	J0

**2. Function list of product types**

**Table 2**

Product Type	Hysteresis Width	Output Form	Output Logic
L type	0%	Nch open-drain output	Active "L"
M type	5.0%	Nch open-drain output	Active "L"
N type	10.0%	Nch open-drain output	Active "L"

**3. Packages**

**Table 3 Package Drawing Codes**

Package Name	Dimension	Tape	Reel	Land
HTMSOP-8	FP008-A-P-SD	FP008-A-C-SD	FP008-A-R-SD	FP008-A-L-SD
HSNT-8(2030)	PP008-A-P-SD	PP008-A-C-SD	PP008-A-R-SD	PP008-A-L-SD
SOT-23-5	MP005-A-P-SD	MP005-A-C-SD	MP005-A-R-SD	—

## ■ Pin Configurations

### 1. HTMSOP-8

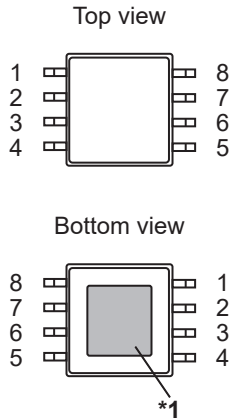

**Figure 3**

- \*1. Connect the heat sink of backside at shadowed area to the board, and set electric potential GND. However, do not use it as the function of electrode.
- \*2. The NC pin is electrically open. The NC pin can be connected to the VDD pin or the VSS pin.
- \*3. Connect a capacitor between the CD pin and the VSS pin. The release delay time can be adjusted according to the capacitance. Moreover, the CD pin is available even when it is open.

**Table 4**

Pin No.	Symbol	Description
1	NC*2	No connection
2	VDD	Voltage input pin
3	NC*2	No connection
4	SENSE	Detection voltage input pin
5	CD*3	Connection pin for release delay time adjustment capacitor
6	VSS	GND pin
7	OUT	Voltage detection output pin
8	NC*2	No connection

### 2. HSNT-8(2030)

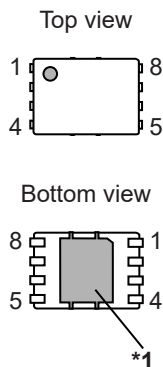

**Figure 4**

- \*1. Connect the heat sink of backside at shadowed area to the board, and set electric potential GND. However, do not use it as the function of electrode.
- \*2. The NC pin is electrically open. The NC pin can be connected to the VDD pin or the VSS pin.
- \*3. Connect a capacitor between the CD pin and the VSS pin. The release delay time can be adjusted according to the capacitance. Moreover, the CD pin is available even when it is open.

**Table 5**

Pin No.	Symbol	Description
1	NC*2	No connection
2	VDD	Voltage input pin
3	NC*2	No connection
4	SENSE	Detection voltage input pin
5	CD*3	Connection pin for release delay time adjustment capacitor
6	VSS	GND pin
7	OUT	Voltage detection output pin
8	NC*2	No connection

**3. SOT-23-5**

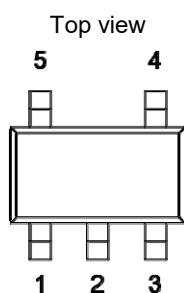

**Figure 5**

**Table 6**

Pin No.	Symbol	Description
1	OUT	Overvoltage detection output pin
2	VSS	GND pin
3	CD*1	Connection pin for release delay capacitor
4	SENSE	Detection voltage input pin
5	VDD	Voltage input pin

- \*1. Connect a capacitor between the CD pin and the VSS pin. The release delay time can be adjusted according to the capacitance.  
 Moreover, the CD pin is available even when it is open.

## ■ Absolute Maximum Ratings

Table 7

(Ta = -40°C to +150°C unless otherwise specified)

Item	Symbol	Absolute Maximum Rating	Unit
Power supply voltage	$V_{DD} - V_{SS}$	$V_{SS} - 0.3$ to $V_{SS} + 45.0$	V
SENSE pin voltage	$V_{SENSE}$	$V_{SS} - 30.0$ to $V_{SS} + 45.0$	V
CD pin input voltage	$V_{CD}$	$V_{SS} - 0.3$ to $V_{DD} + 0.3 \leq V_{SS} + 7.0$	V
Output voltage	$V_{OUT}$	$V_{SS} - 0.3$ to $V_{SS} + 45.0$	V
Output current	$I_{OUT}$	25	mA
Junction temperature	$T_j$	-40 to +150	°C
Operation ambient temperature	$T_{opr}$	-40 to +150	°C
Storage temperature	$T_{stg}$	-40 to +150	°C

**Caution** The absolute maximum ratings are rated values exceeding which the product could suffer physical damage. These values must therefore not be exceeded under any conditions.

## ■ Thermal Resistance Value

Table 8

Item	Symbol	Condition	Min.	Typ.	Max.	Unit	
Junction-to-ambient thermal resistance*1	$\theta_{JA}$	HTMSOP-8	Board A	-	159	-	°C/W
			Board B	-	113	-	°C/W
			Board C	-	39	-	°C/W
			Board D	-	40	-	°C/W
			Board E	-	30	-	°C/W
		HSNT-8(2030)	Board A	-	181	-	°C/W
			Board B	-	135	-	°C/W
			Board C	-	40	-	°C/W
			Board D	-	42	-	°C/W
			Board E	-	32	-	°C/W
		SOT-23-5	Board A	-	192	-	°C/W
			Board B	-	160	-	°C/W
			Board C	-	-	-	°C/W
			Board D	-	-	-	°C/W
			Board E	-	-	-	°C/W

\*1. Test environment: compliance with JEDEC STANDARD JESD51-2A

**Remark** Refer to "■ Power Dissipation" and "Test Board" for details.



■ Electrical Characteristics

Table 9

(Ta = -40°C to +150°C unless otherwise specified)

Item	Symbol	Condition	Min.	Typ.	Max.	Unit	Test Circuit
Detection voltage*1	V <sub>DET</sub>	V <sub>DD</sub> = 13.5 V, 16.0 V ≤ V <sub>DET(S)</sub> ≤ 18.0 V	V <sub>DET(S)</sub> × 0.98	V <sub>DET(S)</sub>	V <sub>DET(S)</sub> × 1.02	V	1
Hysteresis width*2	V <sub>HYS</sub>	L type (V <sub>HYS</sub> = 0%)	–	V <sub>DET</sub> × 0.00	–	V	1
		M type (V <sub>HYS</sub> = 5.0%)	V <sub>DET</sub> × 0.04	V <sub>DET</sub> × 0.05	V <sub>DET</sub> × 0.06	V	1
		N type (V <sub>HYS</sub> = 10.0%)	V <sub>DET</sub> × 0.09	V <sub>DET</sub> × 0.10	V <sub>DET</sub> × 0.11	V	1
Current consumption	I <sub>SS1</sub>	V <sub>DD</sub> = 13.5 V, V <sub>SENSE</sub> = 13.5 V	–	0.6	2.4	μA	4
Operation voltage	V <sub>DD</sub>	–	3.0	–	36.0	V	1
Output current	I <sub>OUT</sub>	OUT pin Nch driver, V <sub>DD</sub> = 3.0 V, V <sub>DS</sub> *3 = 0.1 V, V <sub>SENSE</sub> = V <sub>DET(S)</sub> + 1 V	0.60	–	–	mA	2
Leakage current	I <sub>LEAK</sub>	OUT pin Nch driver, V <sub>DD</sub> = 36 V, V <sub>OUT</sub> = 36 V, V <sub>SENSE</sub> = 13.5 V	–	–	2.0	μA	2
Detection response time*4	t <sub>RESET</sub>	–	–	80	200	μs	3
Release delay time*5	t <sub>DELAY</sub>	C <sub>D</sub> = 3.3 nF	8.0	10.0	12.0	ms	3
SENSE pin resistance	R <sub>SENSE</sub>	–	6.8	–	200	MΩ	4
CD pin discharge ON resistance	R <sub>CDD</sub>	V <sub>DD</sub> = 3.0 V, V <sub>CD</sub> = 0.7 V	0.15	–	0.90	kΩ	–

\*1. V<sub>DET</sub>: Actual detection voltage value, V<sub>DET(S)</sub>: Set detection voltage value

\*2. The release voltage (V<sub>REL</sub>) are as follows.

L type (hysteresis width "Unavailable"): V<sub>REL</sub> = V<sub>DET</sub>

M / N type (hysteresis width "Available"): V<sub>REL</sub> = V<sub>DET</sub> – V<sub>HYS</sub>

\*3. V<sub>DS</sub>: Drain-to-source voltage of the output transistor

\*4. The time period from when the pulse voltage of V<sub>DET(S)</sub> – 1.0 V → V<sub>DET(S)</sub> + 1.0 V is applied to the SENSE pin after V<sub>SENSE</sub> reaches the release voltage once, until V<sub>OUT</sub> reaches 50% of V<sub>DD</sub>.

\*5. V<sub>REL(S)</sub>: Set release voltage value

The time period from when the pulse voltage of V<sub>REL(S)</sub> + 1.0 V → V<sub>REL(S)</sub> – 1.0 V is applied to the SENSE pin to when V<sub>OUT</sub> reaches 50% of V<sub>DD</sub>.

■ Test Circuits

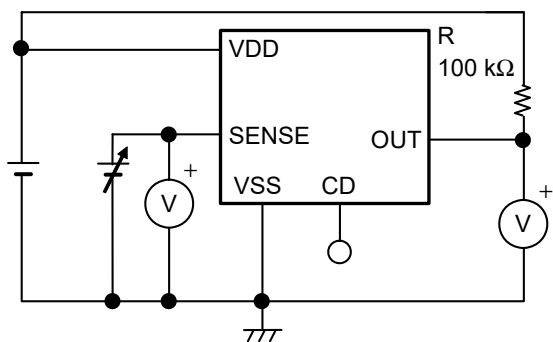

Figure 6 Test Circuit 1

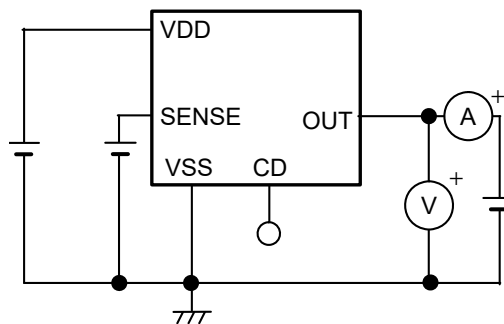

Figure 7 Test Circuit 2

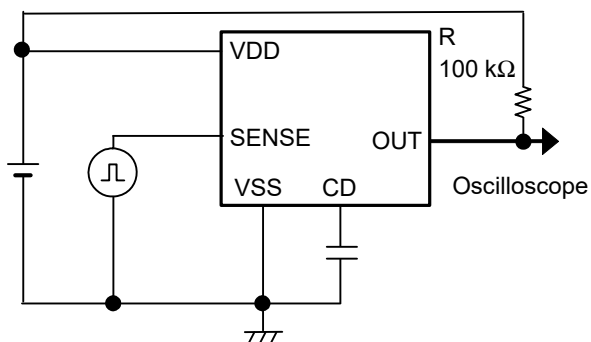

Figure 8 Test Circuit 3

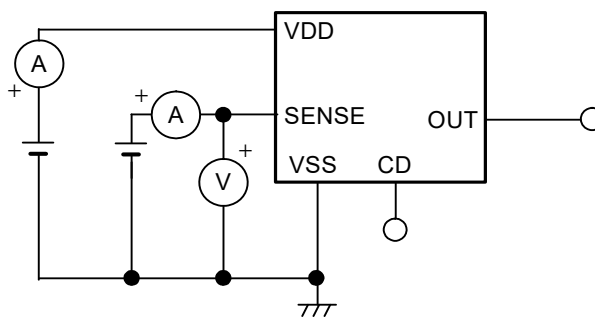
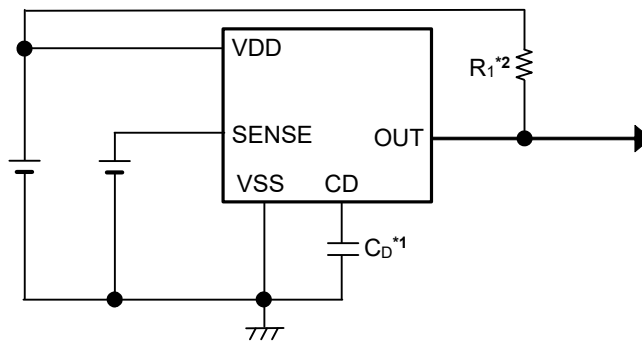

Figure 9 Test Circuit 4

### ■ Standard Circuit



- \*1.  $C_D$  is a release delay time adjustment capacitor. The  $C_D$  should be connected directly to the CD pin and the VSS pin.
- \*2.  $R_1$  are the external pull-up resistors for the reset output pin.

Figure 10

**Caution** The above connection diagram and constants will not guarantee successful operation. Perform thorough evaluation including the temperature characteristics with an actual application to set the constants.

### ■ Condition of Application

Release delay time adjustment capacitor ( $C_D$ ): A ceramic capacitor with capacitance of 1.0 nF or more is recommended.

**Caution** The CD pin is available even when it is open.  
 Refer to "1. Power on sequence" in "■ Usage Precautions" when using it open.

### ■ Selection of Release Delay Time Adjustment Capacitor ( $C_D$ )

In this IC, the release delay time adjustment capacitor ( $C_D$ ) is necessary between the CD pin and the VSS pin to adjust the release delay time ( $t_{DELAY}$ ) of the detector. Refer to "1.4 Delay circuit" in "■ Operation" for details.

**Caution** Perform thorough evaluation including the temperature characteristics with an actual application to select  $C_D$ .

## ■ Explanation of Terms

### 1. Detection voltage ( $V_{DET}$ )

The detection voltage is a SENSE pin voltage at which the output voltage in **Figure 13** turns to "L". The detection voltage varies slightly among products of the same specification. The variation of detection voltage between the specified minimum and the maximum is called the detection voltage range (Refer to "**Figure 11 Detection Voltage**").

Example: In  $V_{DET} = 16.0$  V product, the detection voltage is at any point in the range of  $15.680$  V  $\leq V_{DET} \leq 16.320$  V.  
This means that some  $V_{DET} = 16.0$  V product has  $V_{DET} = 15.680$  V and some has  $V_{DET} = 16.320$  V.

### 2. Release voltage ( $V_{REL}$ )

The release voltage is a SENSE pin voltage at which the output voltage in **Figure 13** turns to "H". The release voltage varies slightly among products of the same specification. The variation of release voltage between the specified minimum and the maximum is called the release voltage range (Refer to "**Figure 12 Release Voltage**").

The release voltage becomes the value differs from the detection voltage within the range shown below.

- M type: 4% to 6% (5% typ.)
- N type: 9% to 11% (10% typ.)

Example: For N-type,  $V_{DET} = 16.0$  V product, the release voltage is at any point in the range of  $13.955$  V  $\leq V_{REL} \leq 14.852$  V despite  $V_{REL} = 14.400$  V typ.

This means that some N type,  $V_{DET} = 16.0$  V product has  $V_{REL} = 13.955$  V and some has  $V_{REL} = 14.852$  V.

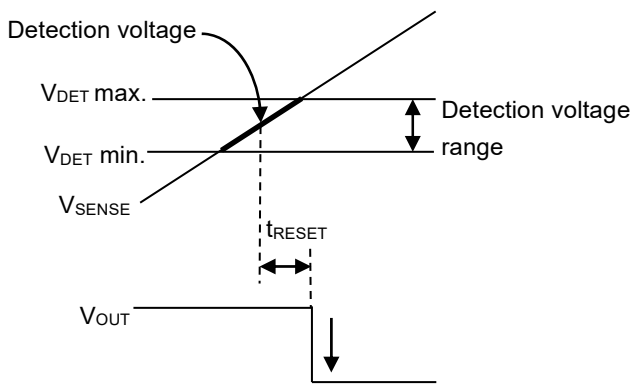

**Figure 11 Detection Voltage**

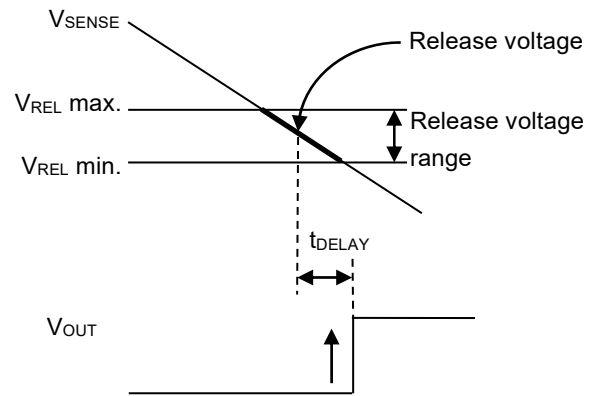

**Figure 12 Release Voltage**

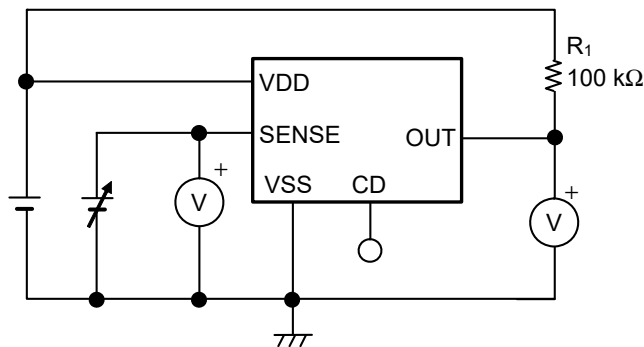

**Figure 13 Test Circuit of Detection Voltage and Release Voltage**

### 3. Hysteresis width ( $V_{HYS}$ )

The hysteresis width is the voltage difference between the detection voltage ( $V_{DET}$ ) and the release voltage ( $V_{REL}$ ). Voltage difference between  $V_{REL}$  and  $V_{DET}$  is the hysteresis width ( $V_{HYS}$ <sup>\*1</sup>) of the OUT pin. Setting the hysteresis width between  $V_{DET}$  and  $V_{REL}$ , prevents malfunction caused by noise on the input voltage.

\*1. Refer to "1.2 S-19115 Series M / N type" in "■ Operation" for details.

### 4. Feed-through current

The feed-through current is a current that flows instantaneously to the VDD pin at the time of detection and release of a voltage detector.

## ■ Operation

### 1. Basic operation

Figure 14 and Figure 16 show that the OUT pin being pulled up by resistors ( $R_1$ ) is an example of basic detector block operation.

#### 1.1 S-19115 Series L type

(1) Release status to detection status

The SENSE pin voltage ( $V_{SENSE}$ ) rises, and when it exceeds the detection voltage ( $V_{DET}$ ), the OUT pin output becomes "L" after detection response time ( $t_{RESET}$ ).

(2) Detection status to release status

$V_{SENSE}$  drops, and when it goes below the release voltage ( $V_{REL} = V_{DET}$ ), the OUT pin output changes to "H" after release delay time ( $t_{DELAY}$ ).

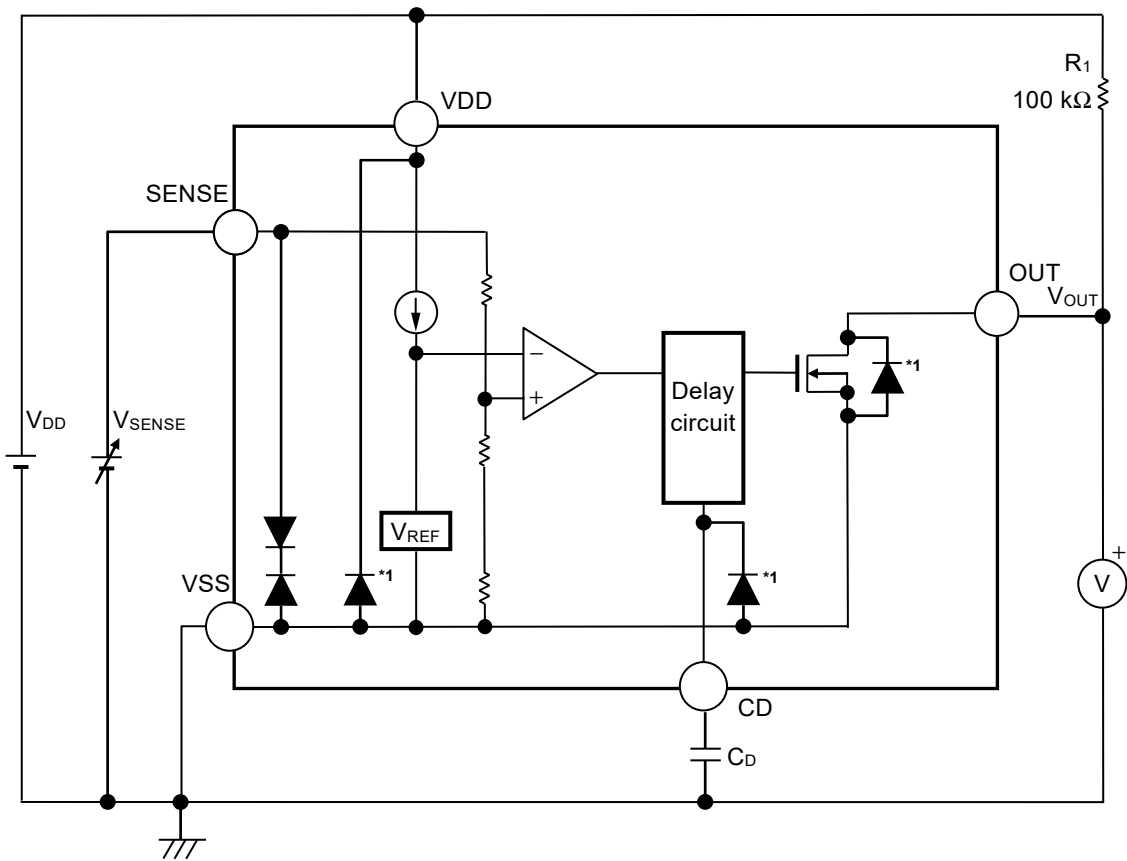

\*1. Parasitic diode

Figure 14 Operation of S-19115 Series L type

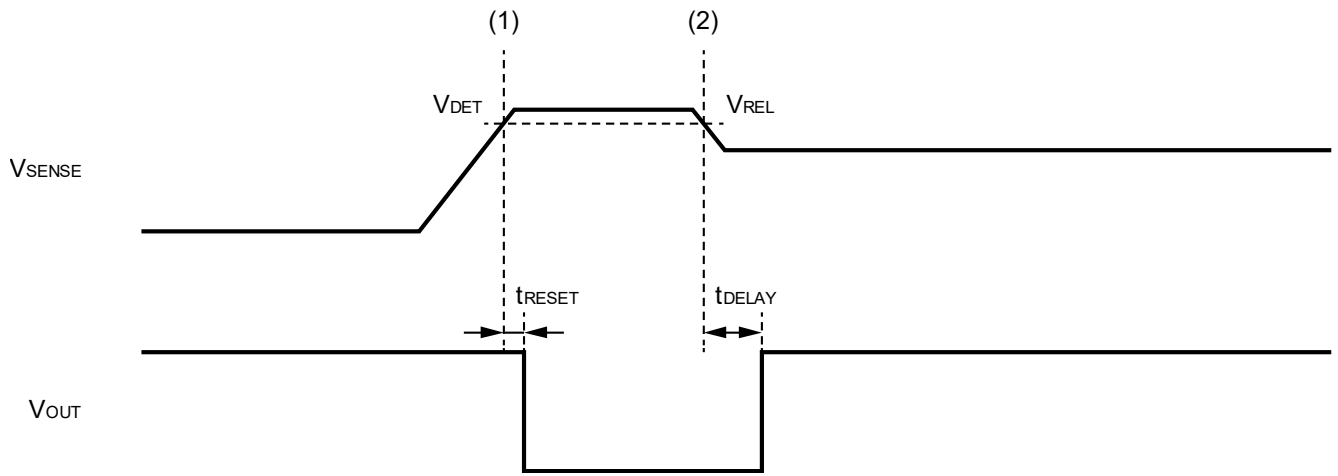
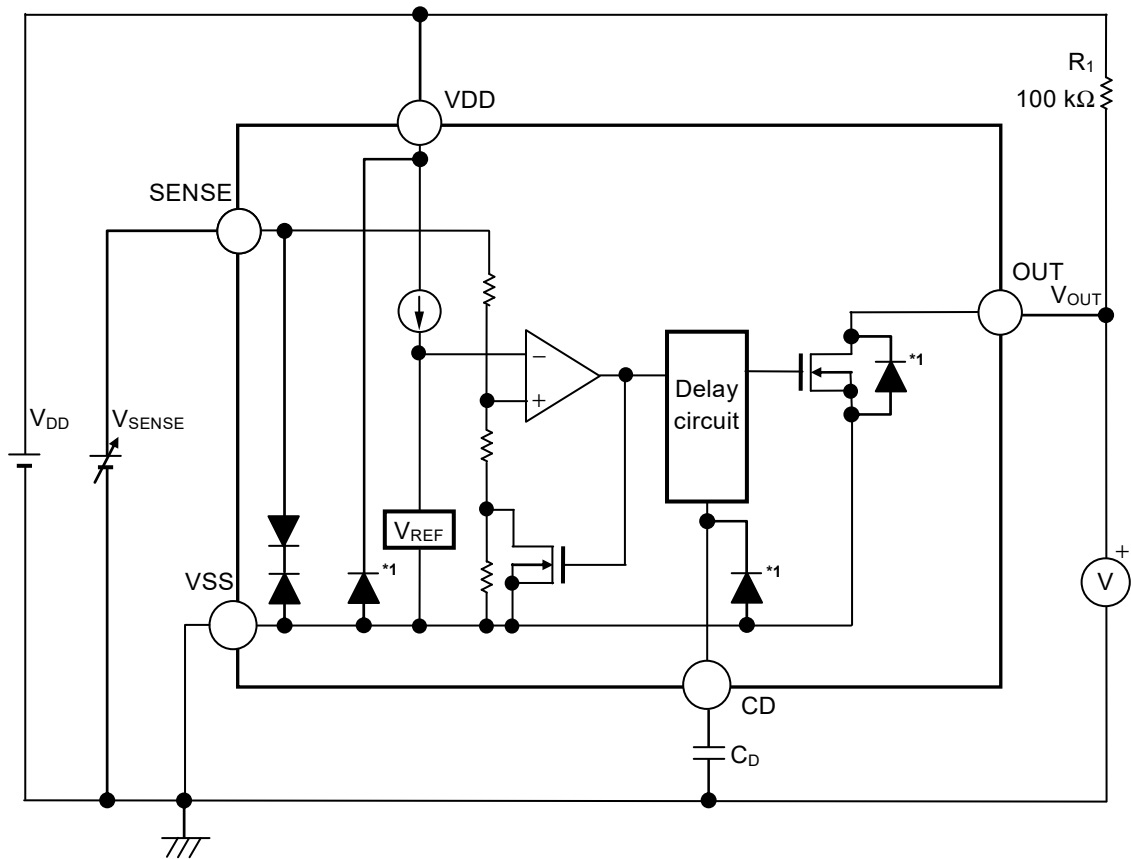

Figure 15 Timing Chart of S-19115 Series L Type

**1.2 S-19115 Series M / N type**

- (1) Release status to detection status  
 The SENSE pin voltage ( $V_{SENSE}$ ) rises, and when it exceeds the detection voltage ( $V_{DET}$ ), the OUT pin output becomes "L" after detection response time ( $t_{RESET}$ ).
- (2) Detection status to release status  
 $V_{SENSE}$  drops, and when it goes below the release voltage ( $V_{REL} = V_{DET} - V_{HYS}$ ), the OUT pin output changes to "H" after release delay time ( $t_{DELAY}$ ).



\*1. Parasitic diode

**Figure 16 Operation of S-19115 Series M / N type**



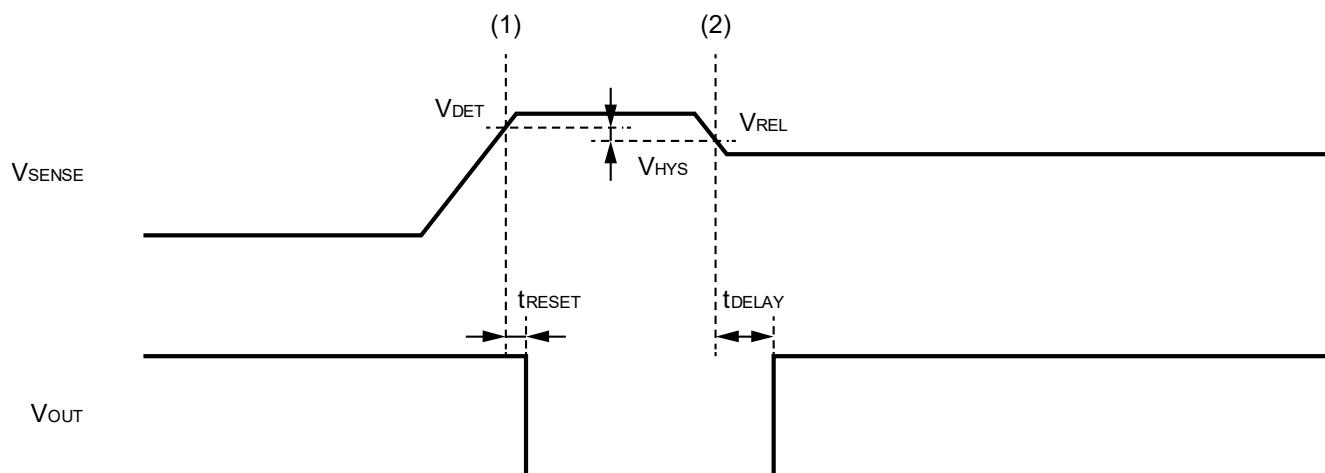

Figure 17 Timing Chart of S-19115 Series M / N Type

### 1.3 SENSE pin

The SENSE pin is the input pin for the detection voltage. The power supply VDD pin and SENSE pin, for voltage detection, are divided. Therefore, as long as a voltage is supplied to the VDD pin, the release signal will be held even if the input voltage to the SENSE pin drops below the minimum operation voltage. Also, the SENSE pin of this IC has a built-in reverse connection protection circuit. Even when the SENSE pin voltage is less than the VSS pin voltage, the voltage flowing from the VSS pin to the SENSE pin is reduced to 0.05 mA typ.

#### 1.3.1 Error when detection voltage is set externally

The detection voltage can be set externally by connecting a node that was resistance-divided by the resistor ( $R_A$ ) and the resistor ( $R_B$ ) to the SENSE pin as shown in **Figure 18**.

For conventional products without the SENSE pin, external resistor cannot be too large since the resistance-divided node must be connected to the VDD pin. This is because a feed-through current will flow through the VDD pin when it goes from detection to release, and if external resistor is large, problems such as oscillation or larger error in the hysteresis width may occur.

In this IC,  $R_A$  and  $R_B$  in **Figure 18** are easily made larger since the resistance-divided node can be connected to the SENSE pin through which no feed-through current flows. However, be careful of error in the current flowing through the internal resistance ( $R_{SENSE}$ ) that will occur.

Although  $R_{SENSE}^{*1}$  in this IC is large to make the error small,  $R_A$  and  $R_B$  should be selected such that the error is within the allowable limits.

\*1. 6.8 M $\Omega$  min.

**1.3.2 Selection of RA and RB**

In **Figure 18**, the relation between the external setting detection voltage (V<sub>DX</sub>) and the actual detection voltage (V<sub>DET</sub>) is ideally calculated by the equation below.

$$V_{DX} = V_{DET} \times \left(1 + \frac{R_A}{R_B}\right) \dots\dots\dots(1)$$

However, in reality there is an error in the current flowing through R<sub>SENSE</sub>. When considering this error, the relation between V<sub>DX</sub> and V<sub>DET</sub> is calculated as follows.

$$\begin{aligned} V_{DX} &= V_{DET} \times \left(1 + \frac{R_A}{R_B \parallel R_{SENSE}}\right) \\ &= V_{DET} \times \left(1 + \frac{R_A}{\frac{R_B \times R_{SENSE}}{R_B + R_{SENSE}}}\right) \\ &= V_{DET} \times \left(1 + \frac{R_A}{R_B}\right) + \frac{R_A}{R_{SENSE}} \times V_{DET} \dots\dots\dots(2) \end{aligned}$$

By using equations (1) and (2), the error is calculated as  $V_{DET} \times \frac{R_A}{R_{SENSE}}$ .

The error rate is calculated as follows by dividing the error by the right-hand side of equation (1).

$$\frac{R_A \times R_B}{R_{SENSE} \times (R_A + R_B)} \times 100 [\%] = \frac{R_A \parallel R_B}{R_{SENSE}} \times 100 [\%] \dots\dots(3)$$

As seen in equation (3), the smaller the resistance values of R<sub>A</sub> and R<sub>B</sub> compared to R<sub>SENSE</sub>, the smaller the error rate becomes.

Also, the relation between the external setting hysteresis width (V<sub>HX</sub>) and the hysteresis width (V<sub>HYS</sub>) is calculated by equation below. Error due to R<sub>SENSE</sub> also occurs to the relation in a similar way to the detection voltage.

$$V_{HX} = V_{HYS} \times \left(1 + \frac{R_A}{R_B}\right) \dots\dots\dots(4)$$

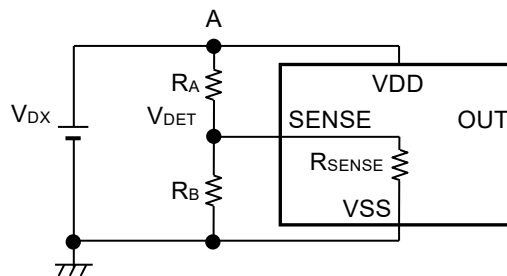

**Figure 18** Detection Voltage External Setting Circuit

**Caution** If R<sub>A</sub> and R<sub>B</sub> are large, the SENSE pin input impedance becomes higher and may cause a malfunction due to noise. In this case, connect a capacitor between the SENSE pin and the VSS pin.

#### 1.4 Delay circuit

The delay circuit comes with a function for adjusting the release delay time ( $t_{DELAY}$ ) from when the SENSE pin voltage ( $V_{SENSE}$ ) reaches the detection voltage ( $V_{REL} = V_{DET} - V_{HYS}$ ) or lower to when the output from OUT pin inverts.

$t_{DELAY}$  is determined by the delay coefficient, the release delay time adjustment capacitor ( $C_D$ ) and the release delay time when the CD pin is open ( $t_{DELAY0}$ ). They are calculated by the equations below.

$$t_{DELAY} [\text{ms}] = \text{Delay coefficient} \times C_D [\text{nF}] + t_{DELAY0} [\text{ms}]$$

**Table 10**

Operation Temperature	Delay Coefficient		
	Min.	Typ.	Max.
Ta = +150°C	2.52	3.00	3.58
Ta = +125°C	2.65	3.03	3.41
Ta = +25°C	2.92	3.06	3.14
Ta = -40°C	2.65	3.09	3.41

**Table 11**

Operation Temperature	Release Delay Time when CD Pin is Open ( $t_{DELAY0}$ )		
	Min.	Typ.	Max.
Ta = +150°C	0.05	0.09	0.16
Ta = +125°C	0.05	0.09	0.17
Ta = +25°C	0.06	0.11	0.19
Ta = -40°C	0.06	0.13	0.25

- Caution 1.** Mounted board layout should be made in such a way that no current flows into or flows from the CD pin since the impedance of the CD pin is high, otherwise correct delay time cannot be provided.
2. There is no limit for the capacitance of  $C_D$  as long as the leakage current of the capacitor can be ignored against the built-in constant current value (approximately 160 nA). The leakage current may cause error in delay time. When the leakage current is larger than the built-in constant current, no detect or release takes place.
  3. The above equations will not guarantee successful operation. Determine the capacitance of  $C_D$  through thorough evaluation including temperature characteristics in the actual usage conditions.

## ■ Usage Precautions

### 1. Power on sequence

#### 1.1 Power on when release delay time adjustment capacitor ( $C_D$ ) $\geq 1$ nF

When connecting a 1 nF or larger capacitor to the CD pin, there is no specific order for turning on the SENSE and VDD pins.

#### 1.2 Power on when release delay time adjustment capacitor ( $C_D$ ) $< 1$ nF or CD pin is open

When connecting a capacitor of less than 1 nF to the CD pin, turn on the VDD pin before the SENSE pin as shown in **Figure 19**.

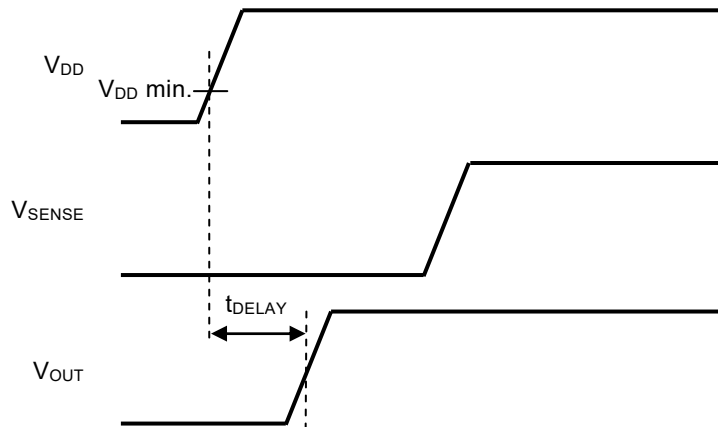

Figure 19

**Caution** When connecting a capacitor of less than 1 nF to the CD pin and the SENSE pin is turned on before the VDD pin, a release may mistakenly occur even if  $V_{SENSE}$  is less than  $V_{REL}$ .

## ■ Precautions

- Do not apply an electrostatic discharge to this IC that exceeds the performance ratings of the built-in electrostatic protection circuit.
- Because the SENSE pin has a high impedance, malfunctions may occur due to noise.  
Be careful of wiring adjoining SENSE pin wiring in actual applications.
- When designing for mass production using an application circuit described herein, the product deviation and temperature characteristics should be taken into consideration. ABLIC Inc. shall not bear any responsibility for patent infringements related to products using the circuits described herein.
- ABLIC Inc. claims no responsibility for any disputes arising out of or in connection with any infringement by products including this IC of patents owned by a third party.

■ Characteristics (Typical Data)

1. Detection voltage ( $V_{DET}$ ), Release voltage ( $V_{REL}$ ) vs. Temperature ( $T_a$ )

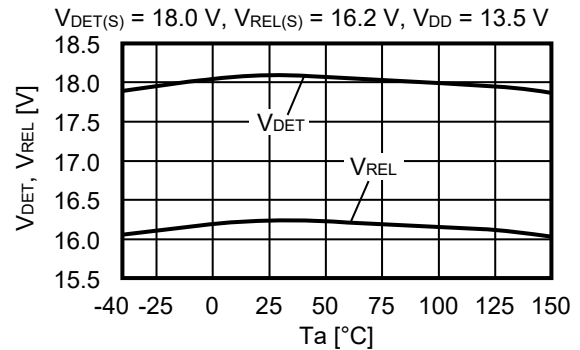
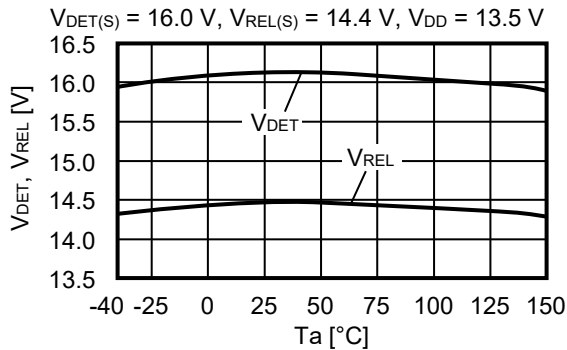

2. Detection voltage ( $V_{DET}$ ), Release voltage ( $V_{REL}$ ) vs. Power supply voltage ( $V_{DD}$ )

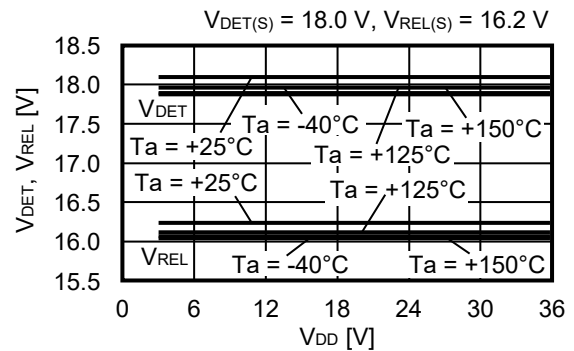
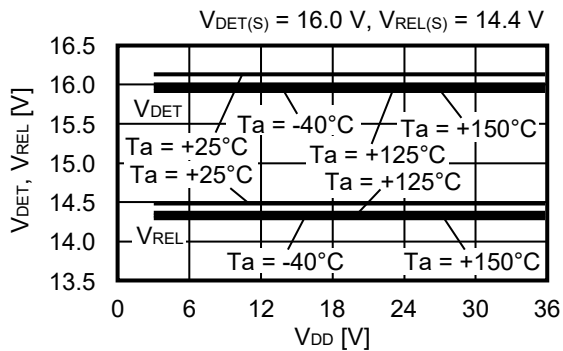

3. Hysteresis width ( $V_{HYS}$ ) vs. Temperature ( $T_a$ )

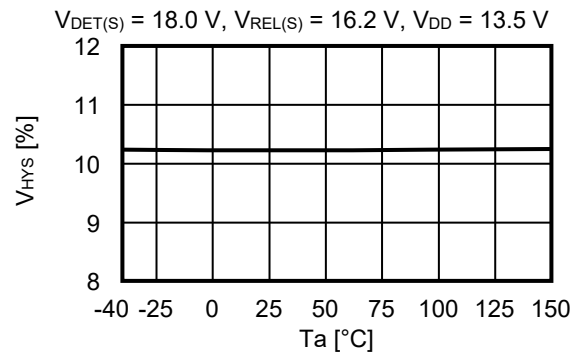
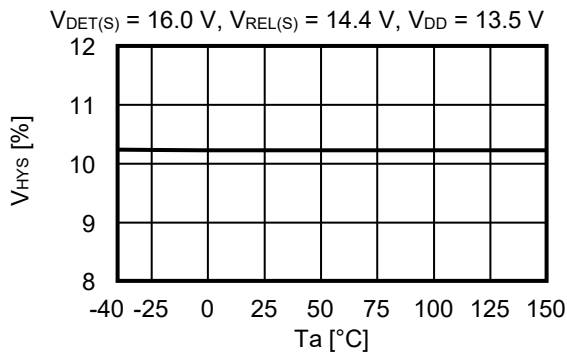

4. Hysteresis width ( $V_{HYS}$ ) vs. Power supply voltage ( $V_{DD}$ )

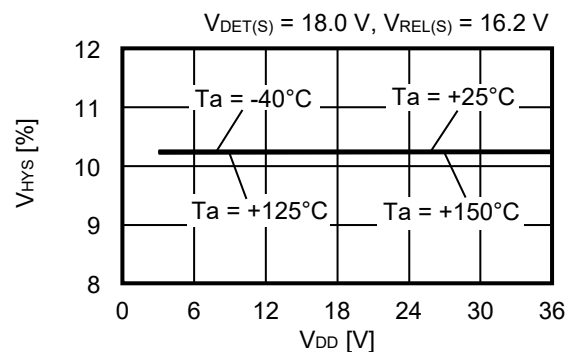
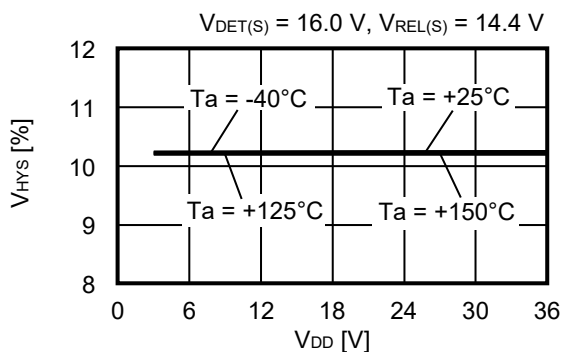

**5. Current consumption ( $I_{SS1}$ ) vs. Temperature ( $T_a$ )**

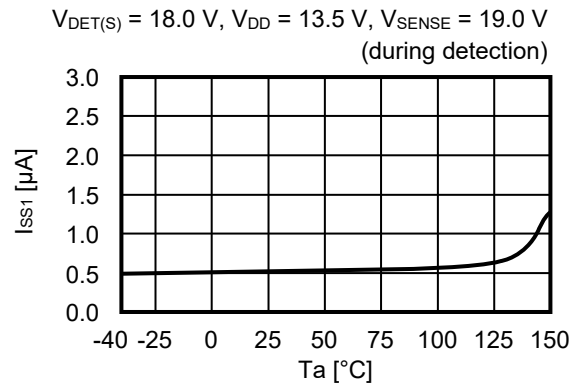
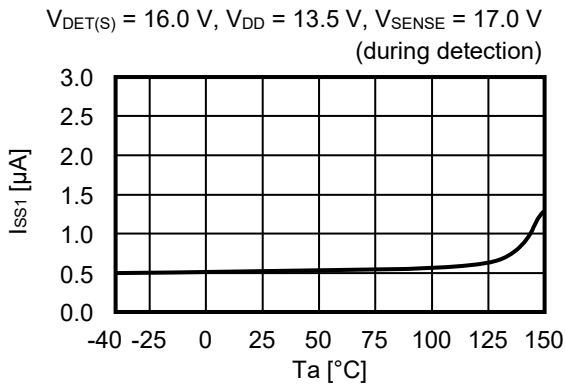
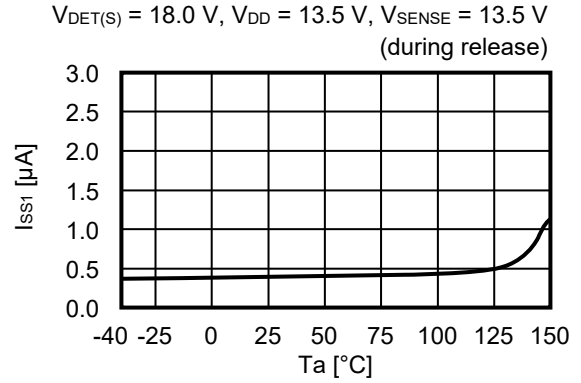
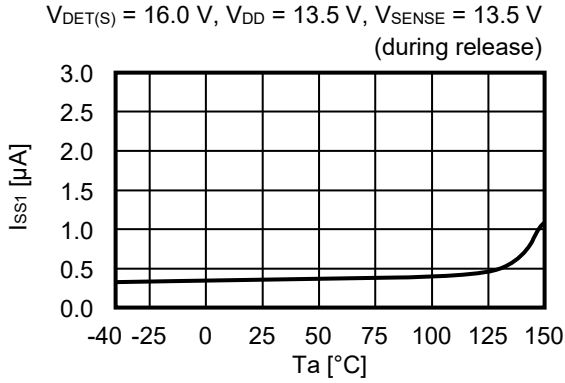

**6. Current consumption ( $I_{SS1}$ ) vs. Power supply voltage ( $V_{DD}$ ) (No load)**

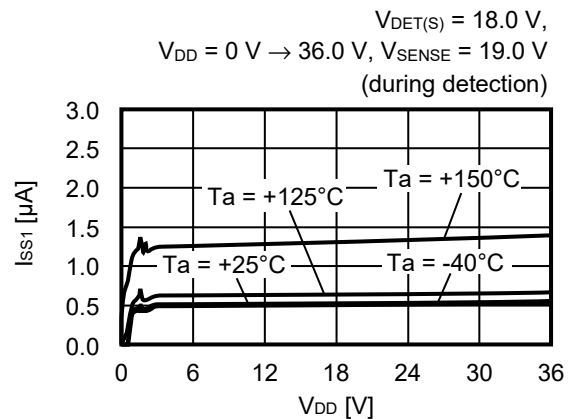
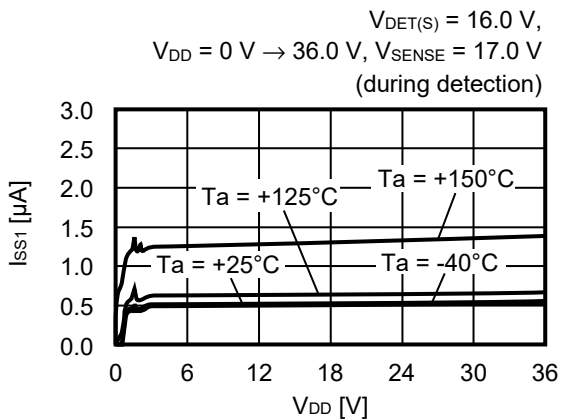
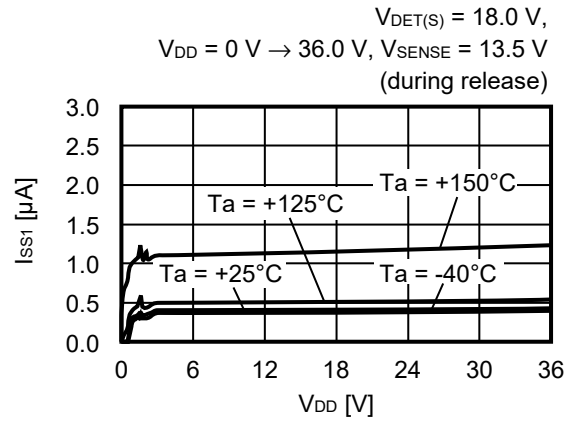
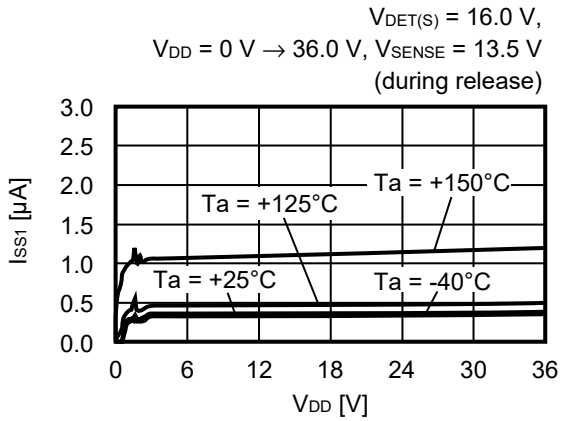



**7. Nch transistor output current ( $I_{OUT}$ ) vs.  $V_{DS}$**

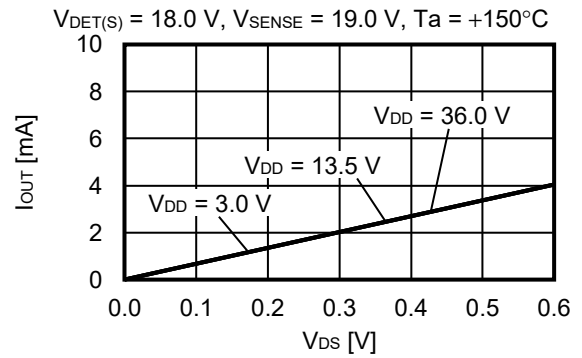
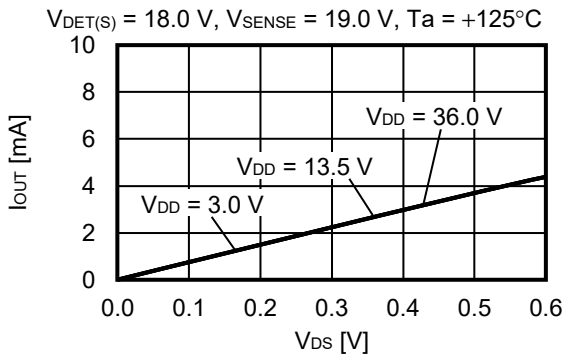
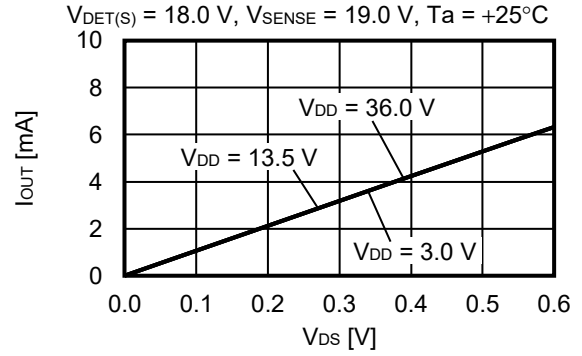
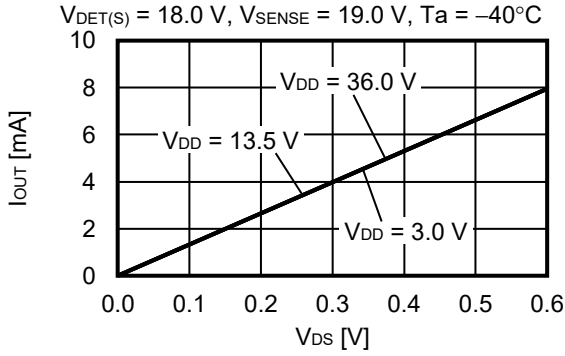

**Remark**  $V_{DS}$ : Drain-to-source voltage of the output transistor

**8. Nch transistor output current ( $I_{OUT}$ ) vs. Power supply voltage ( $V_{DD}$ )**

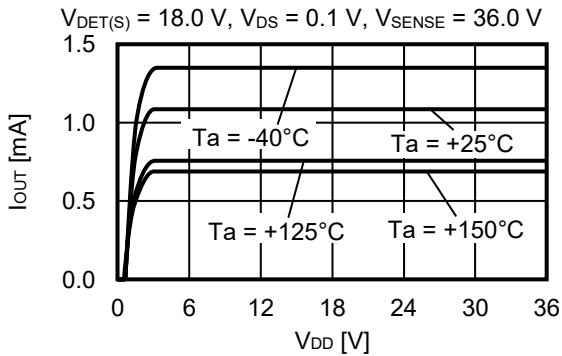

**Remark**  $V_{DS}$ : Drain-to-source voltage of the output transistor

**9. Output voltage ( $V_{OUT}$ ) vs. SENSE pin voltage ( $V_{SENSE}$ )**

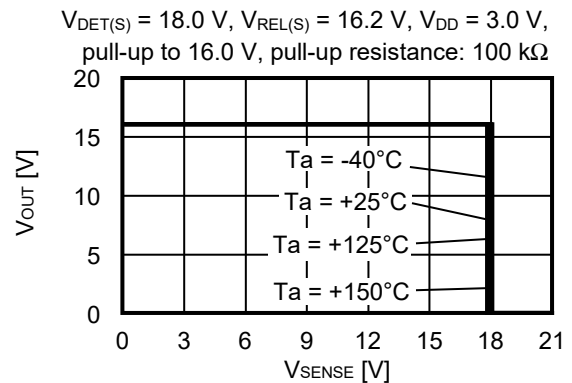
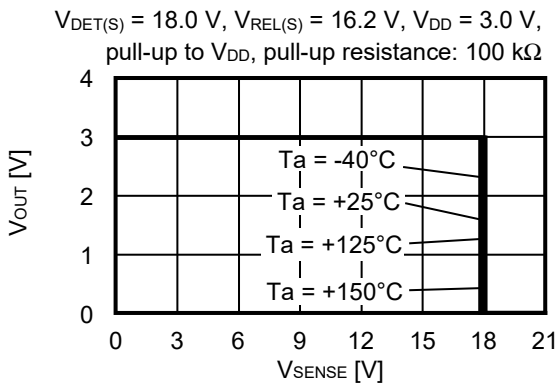

**10. Dynamic response vs. Output pin capacitance (C<sub>OUT</sub>) (CD pin; open)**

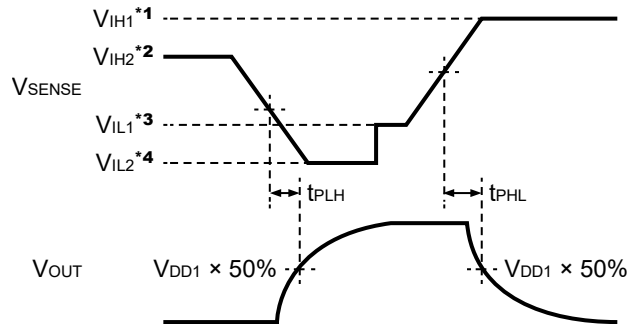
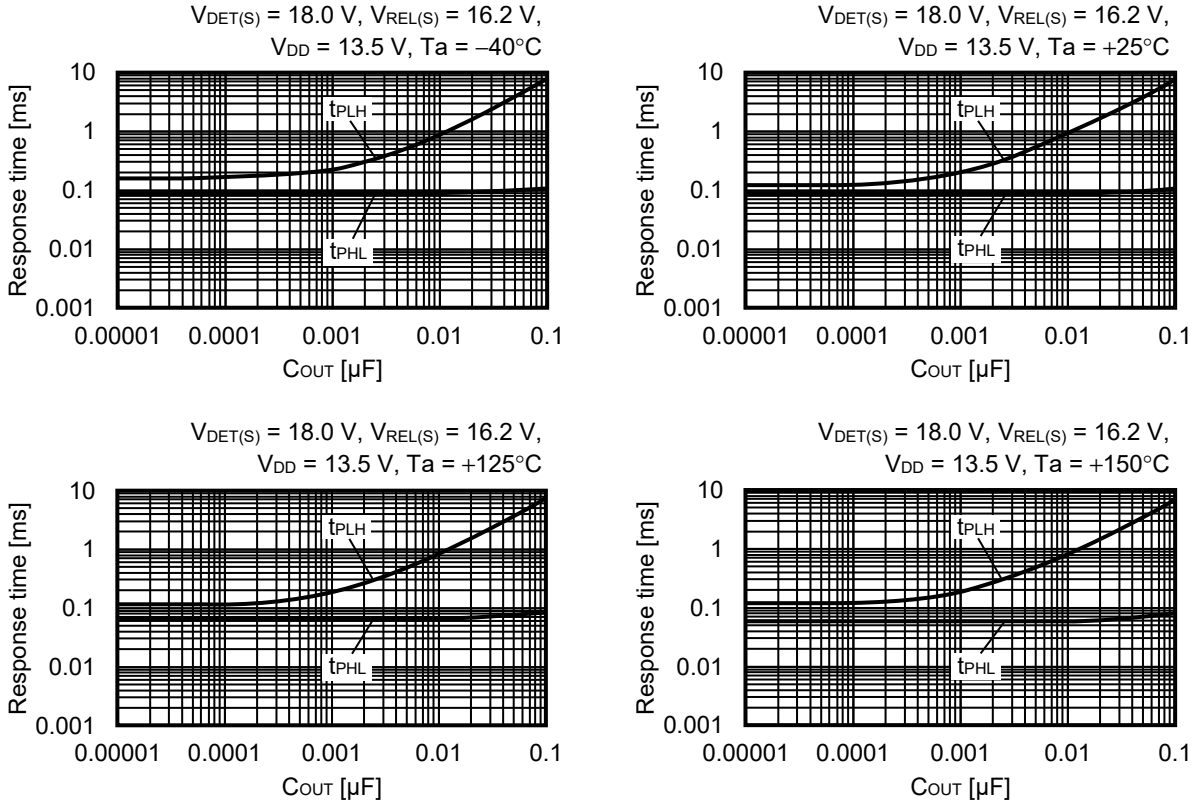

- \*1.  $V_{IH1} = V_{DET(S)} + 1.0\text{ V}$
- \*2.  $V_{IH2} = V_{REL(S)} + 1.0\text{ V}$
- \*3.  $V_{IL1} = V_{DET(S)} - 1.0\text{ V}$
- \*4.  $V_{IL2} = V_{REL(S)} - 1.0\text{ V}$

**Figure 20 Test Condition of Response Time**

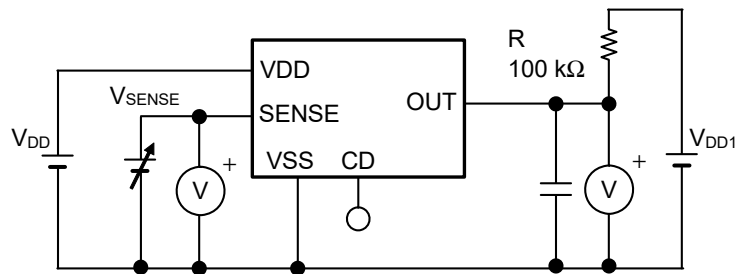
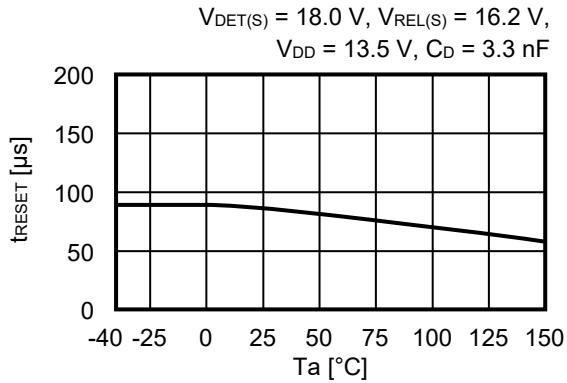

**Figure 21 Test Circuit of Response Time**

**Caution** The above connection diagram and constants will not guarantee successful operation. Perform thorough evaluation including the temperature characteristics with an actual application to set the constants.

■ Reference Data

1. Detection response time ( $t_{\text{RESET}}$ ) vs. Temperature ( $T_a$ )



2. Detection response time ( $t_{\text{RESET}}$ ) vs. Power supply voltage ( $V_{\text{DD}}$ )

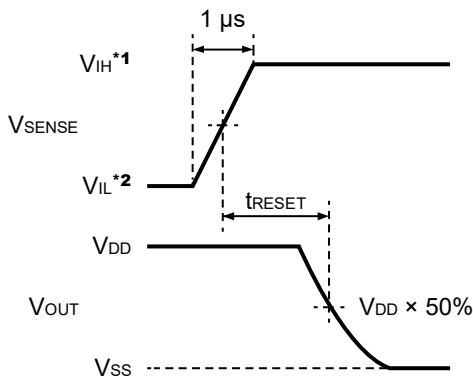
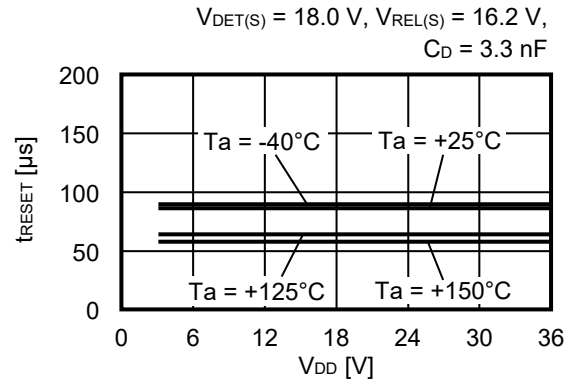

- \*1.  $V_{\text{IH}} = V_{\text{DET(S)}} + 1.0 \text{ V}$
- \*2.  $V_{\text{IL}} = V_{\text{DET(S)}} - 1.0 \text{ V}$

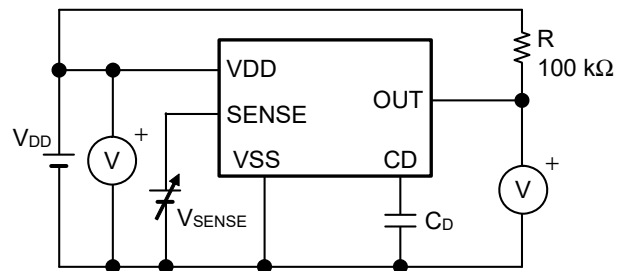
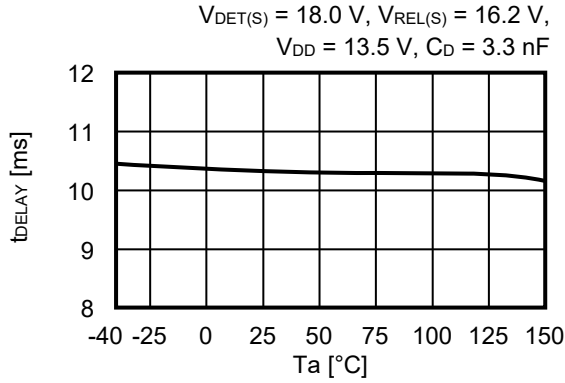

Figure 22 Test Condition of Detection Response Time

Figure 23 Test Circuit of Detection Response Time

**Caution** The above connection diagram and constants will not guarantee successful operation. Perform thorough evaluation including the temperature characteristics with an actual application to set the constants.

**3. Release delay time ( $t_{\text{DELAY}}$ ) vs. Temperature ( $T_a$ )**



**4. Release delay time ( $t_{\text{DELAY}}$ ) vs. Power supply voltage ( $V_{\text{DD}}$ )**

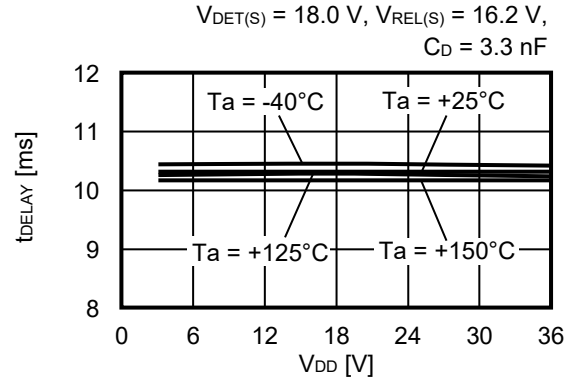

**5. Release delay time ( $t_{\text{DELAY}}$ ) vs. CD pin capacitance ( $C_{\text{D}}$ ) (Without output pin capacitance)**

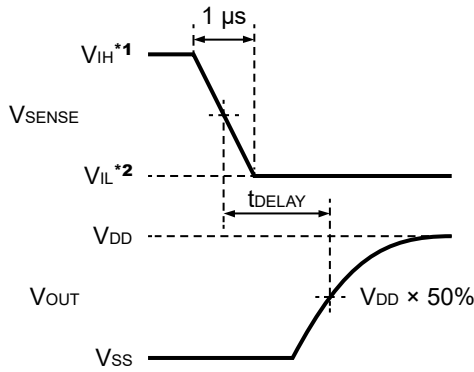
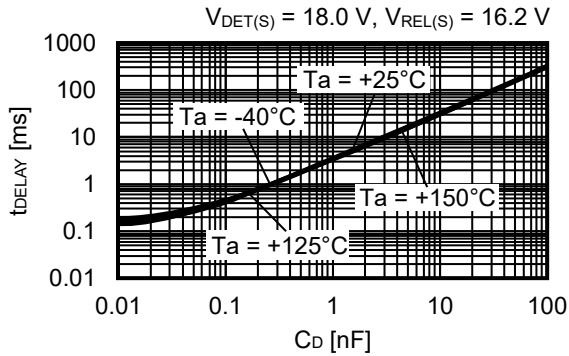

- \*1.  $V_{\text{IH}} = V_{\text{REL(S)}} + 1.0 \text{ V}$
- \*2.  $V_{\text{IL}} = V_{\text{REL(S)}} - 1.0 \text{ V}$

**Figure 24 Test Condition of Release Delay Time**

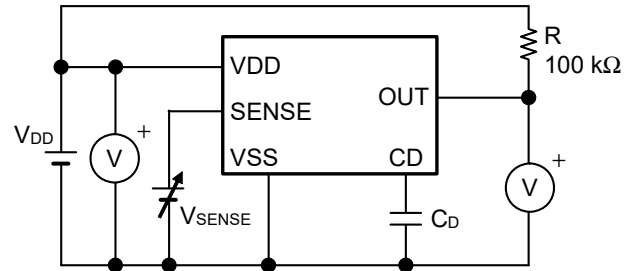
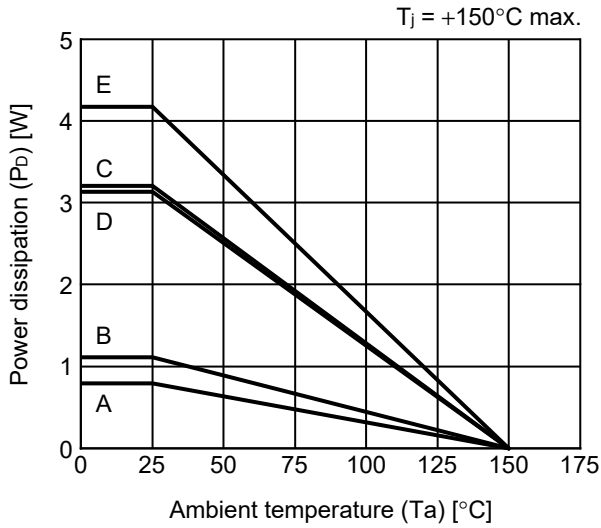

**Figure 25 Test Circuit of Release Delay Time**

**Caution** The above connection diagram and constants will not guarantee successful operation. Perform thorough evaluation including the temperature characteristics with an actual application to set the constants.

■ Power Dissipation

HTMSOP-8



Board	Power Dissipation (P <sub>D</sub> )
A	0.79 W
B	1.11 W
C	3.21 W
D	3.13 W
E	4.17 W

HSNT-8(2030)

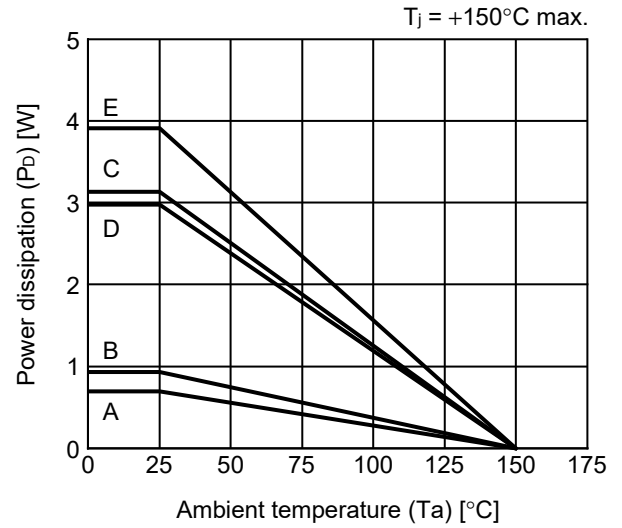

Board	Power Dissipation (P <sub>D</sub> )
A	0.69 W
B	0.93 W
C	3.13 W
D	2.98 W
E	3.91 W

SOT-23-5

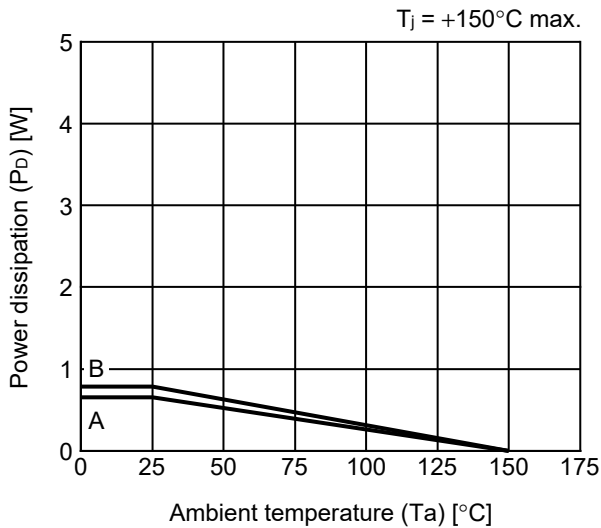

Board	Power Dissipation (P <sub>D</sub> )
A	0.65 W
B	0.78 W
C	—
D	—
E	—

# HTMSOP-8 Test Board

 IC Mount Area

(1) Board A

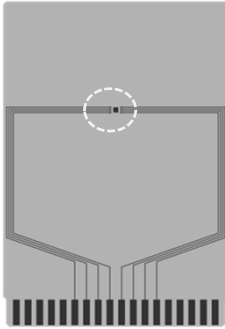

Item		Specification
Size [mm]		114.3 x 76.2 x t1.6
Material		FR-4
Number of copper foil layer		2
Copper foil layer [mm]	1	Land pattern and wiring for testing: t0.070
	2	-
	3	-
	4	74.2 x 74.2 x t0.070
Thermal via		-

(2) Board B

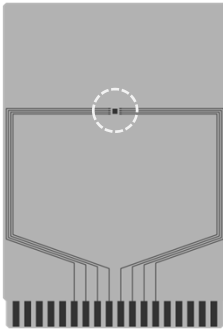

Item		Specification
Size [mm]		114.3 x 76.2 x t1.6
Material		FR-4
Number of copper foil layer		4
Copper foil layer [mm]	1	Land pattern and wiring for testing: t0.070
	2	74.2 x 74.2 x t0.035
	3	74.2 x 74.2 x t0.035
	4	74.2 x 74.2 x t0.070
Thermal via		-

(3) Board C

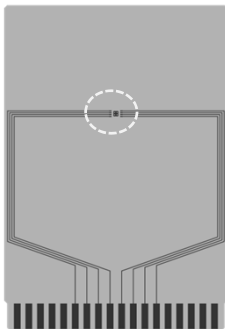

Item		Specification
Size [mm]		114.3 x 76.2 x t1.6
Material		FR-4
Number of copper foil layer		4
Copper foil layer [mm]	1	Land pattern and wiring for testing: t0.070
	2	74.2 x 74.2 x t0.035
	3	74.2 x 74.2 x t0.035
	4	74.2 x 74.2 x t0.070
Thermal via		Number: 4 Diameter: 0.3 mm



enlarged view

No. HTMSOP8-A-Board-SD-1.0

# HTMSOP-8 Test Board

 IC Mount Area

## (4) Board D

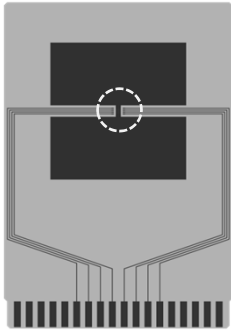

Item	Specification	
Size [mm]	114.3 x 76.2 x t1.6	
Material	FR-4	
Number of copper foil layer	4	
Copper foil layer [mm]	1	Pattern for heat radiation: 2000mm <sup>2</sup> t0.070
	2	74.2 x 74.2 x t0.035
	3	74.2 x 74.2 x t0.035
	4	74.2 x 74.2 x t0.070
Thermal via	-	



enlarged view

## (5) Board E

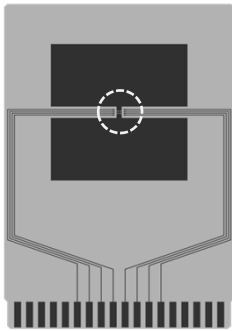

Item	Specification	
Size [mm]	114.3 x 76.2 x t1.6	
Material	FR-4	
Number of copper foil layer	4	
Copper foil layer [mm]	1	Pattern for heat radiation: 2000mm <sup>2</sup> t0.070
	2	74.2 x 74.2 x t0.035
	3	74.2 x 74.2 x t0.035
	4	74.2 x 74.2 x t0.070
Thermal via	Number: 4 Diameter: 0.3 mm	



enlarged view

No. HTMSOP8-A-Board-SD-1.0

# HSNT-8(2030) Test Board

 IC Mount Area

(1) Board A

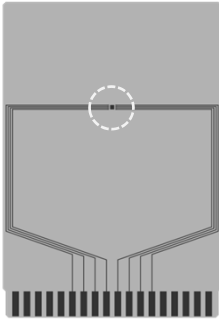

Item	Specification	
Size [mm]	114.3 x 76.2 x t1.6	
Material	FR-4	
Number of copper foil layer	2	
Copper foil layer [mm]	1	Land pattern and wiring for testing: t0.070
	2	-
	3	-
	4	74.2 x 74.2 x t0.070
Thermal via	-	

(2) Board B

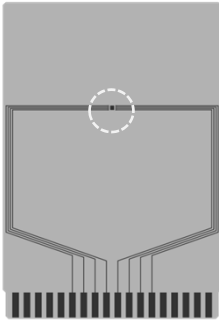

Item	Specification	
Size [mm]	114.3 x 76.2 x t1.6	
Material	FR-4	
Number of copper foil layer	4	
Copper foil layer [mm]	1	Land pattern and wiring for testing: t0.070
	2	74.2 x 74.2 x t0.035
	3	74.2 x 74.2 x t0.035
	4	74.2 x 74.2 x t0.070
Thermal via	-	

(3) Board C

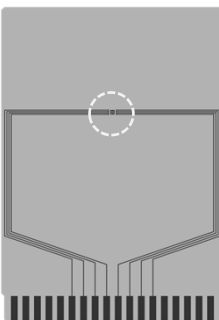

Item	Specification	
Size [mm]	114.3 x 76.2 x t1.6	
Material	FR-4	
Number of copper foil layer	4	
Copper foil layer [mm]	1	Land pattern and wiring for testing: t0.070
	2	74.2 x 74.2 x t0.035
	3	74.2 x 74.2 x t0.035
	4	74.2 x 74.2 x t0.070
Thermal via	Number: 4 Diameter: 0.3 mm	



enlarged view

No. HSNT8-A-Board-SD-2.0



# HSNT-8(2030) Test Board

 IC Mount Area

## (4) Board D

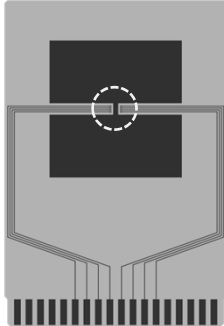

Item	Specification	
Size [mm]	114.3 x 76.2 x t1.6	
Material	FR-4	
Number of copper foil layer	4	
Copper foil layer [mm]	1	Pattern for heat radiation: 2000mm <sup>2</sup> t0.070
	2	74.2 x 74.2 x t0.035
	3	74.2 x 74.2 x t0.035
	4	74.2 x 74.2 x t0.070
Thermal via	-	



enlarged view

## (5) Board E

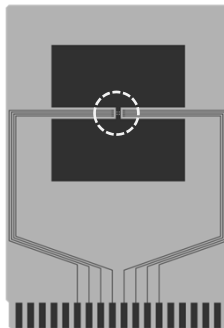

Item	Specification	
Size [mm]	114.3 x 76.2 x t1.6	
Material	FR-4	
Number of copper foil layer	4	
Copper foil layer [mm]	1	Pattern for heat radiation: 2000mm <sup>2</sup> t0.070
	2	74.2 x 74.2 x t0.035
	3	74.2 x 74.2 x t0.035
	4	74.2 x 74.2 x t0.070
Thermal via	Number: 4 Diameter: 0.3 mm	



enlarged view

No. HSNT8-A-Board-SD-2.0

# SOT-23-3/3S/5/6 Test Board

 IC Mount Area

(1) Board A

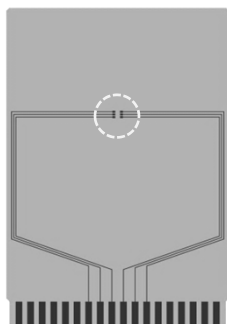

Item	Specification	
Size [mm]	114.3 x 76.2 x t1.6	
Material	FR-4	
Number of copper foil layer	2	
Copper foil layer [mm]	1	Land pattern and wiring for testing: t0.070
	2	-
	3	-
	4	74.2 x 74.2 x t0.070
Thermal via	-	

(2) Board B

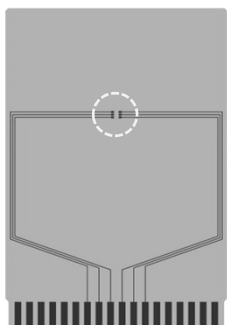

Item	Specification	
Size [mm]	114.3 x 76.2 x t1.6	
Material	FR-4	
Number of copper foil layer	4	
Copper foil layer [mm]	1	Land pattern and wiring for testing: t0.070
	2	74.2 x 74.2 x t0.035
	3	74.2 x 74.2 x t0.035
	4	74.2 x 74.2 x t0.070
Thermal via	-	

No. SOT23x-A-Board-SD-2.0

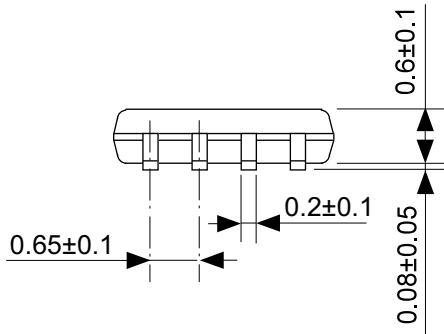
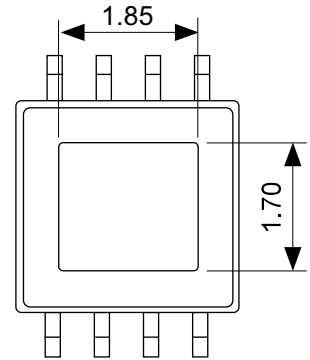
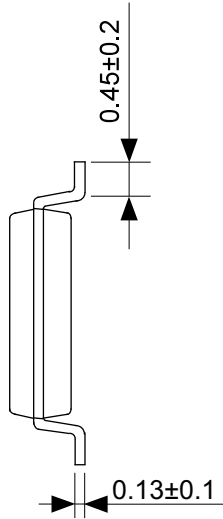
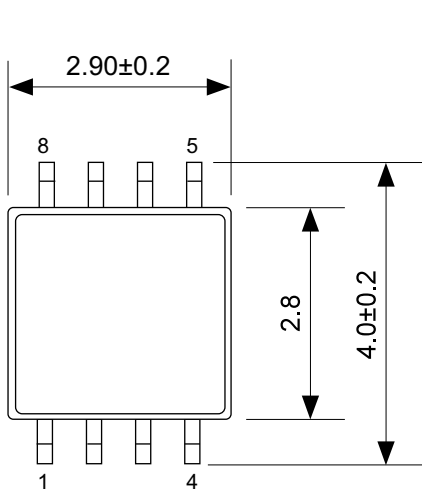

No. FP008-A-P-SD-2.0

TITLE	HTMSOP8-A-PKG Dimensions
No.	FP008-A-P-SD-2.0
ANGLE	
UNIT	mm
<b>ABLIC Inc.</b>	

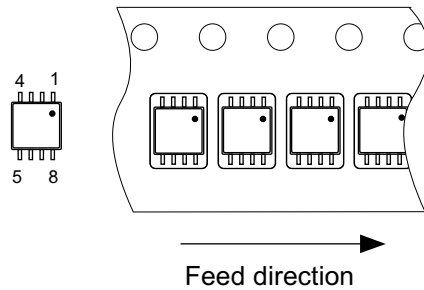
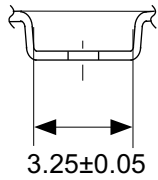
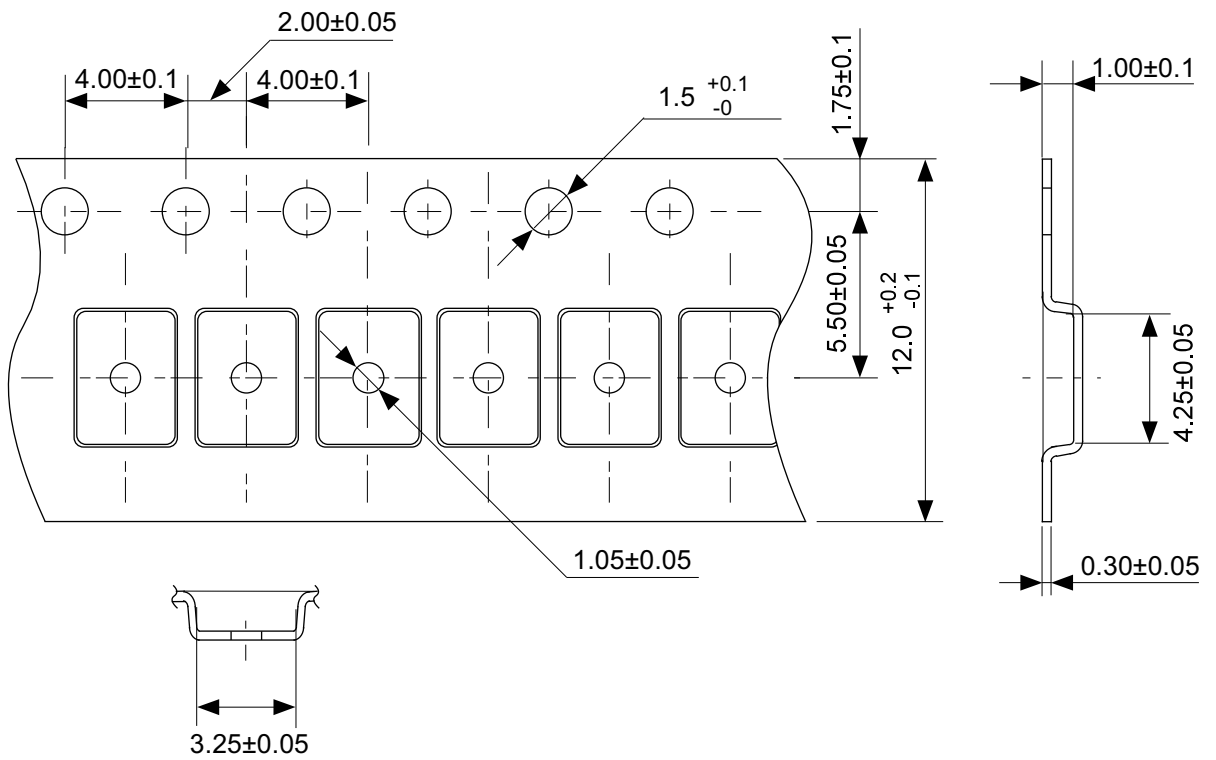

No. FP008-A-C-SD-1.0

TITLE	HTMSOP8-A-Carrier Tape
No.	FP008-A-C-SD-1.0
ANGLE	
UNIT	mm
<b>ABLIC Inc.</b>	

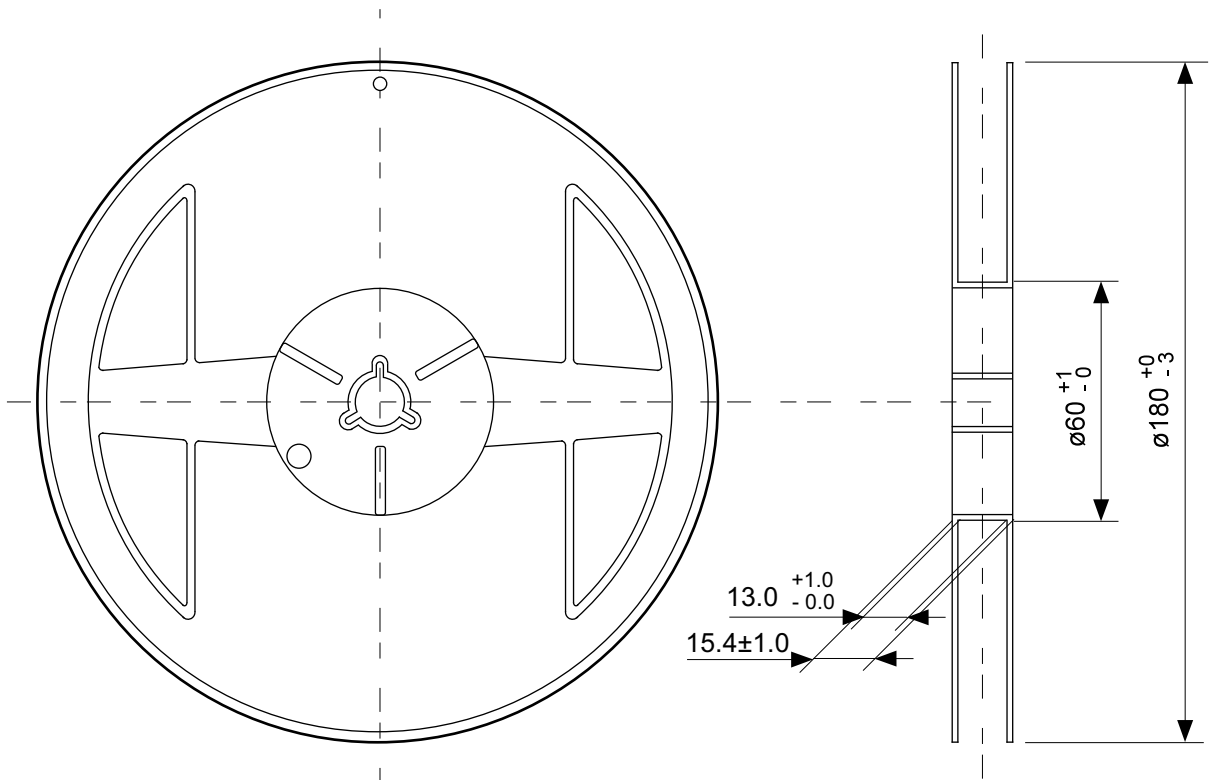

Enlarged drawing in the central part

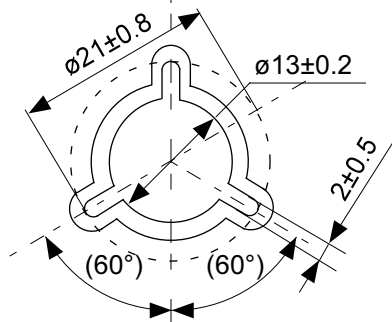

No. FP008-A-R-SD-2.0

TITLE	HTMSOP8-A-Reel		
No.	FP008-A-R-SD-2.0		
ANGLE		QTY.	4,000
UNIT	mm		
<b>ABLIC Inc.</b>			

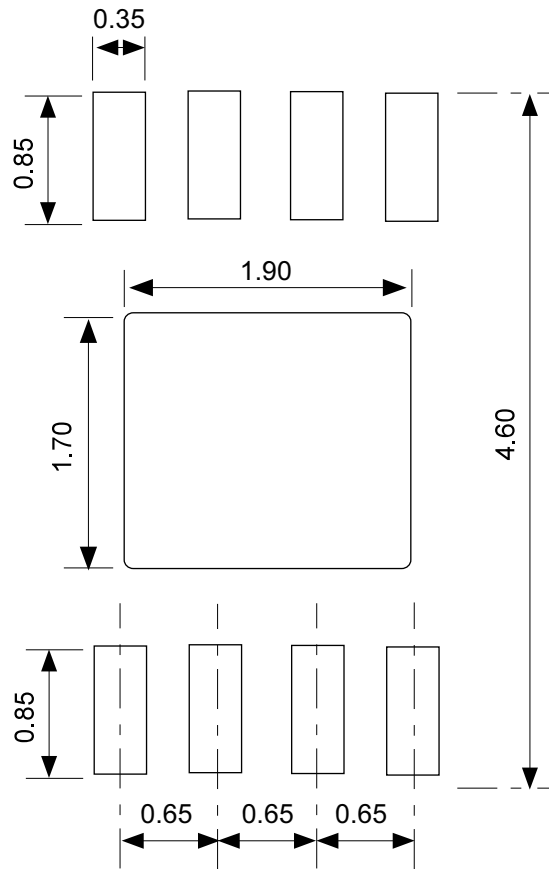

No. FP008-A-L-SD-2.0

TITLE	HTMSOP8-A -Land Recommendation
No.	FP008-A-L-SD-2.0
ANGLE	
UNIT	mm
<b>ABLIC Inc.</b>	

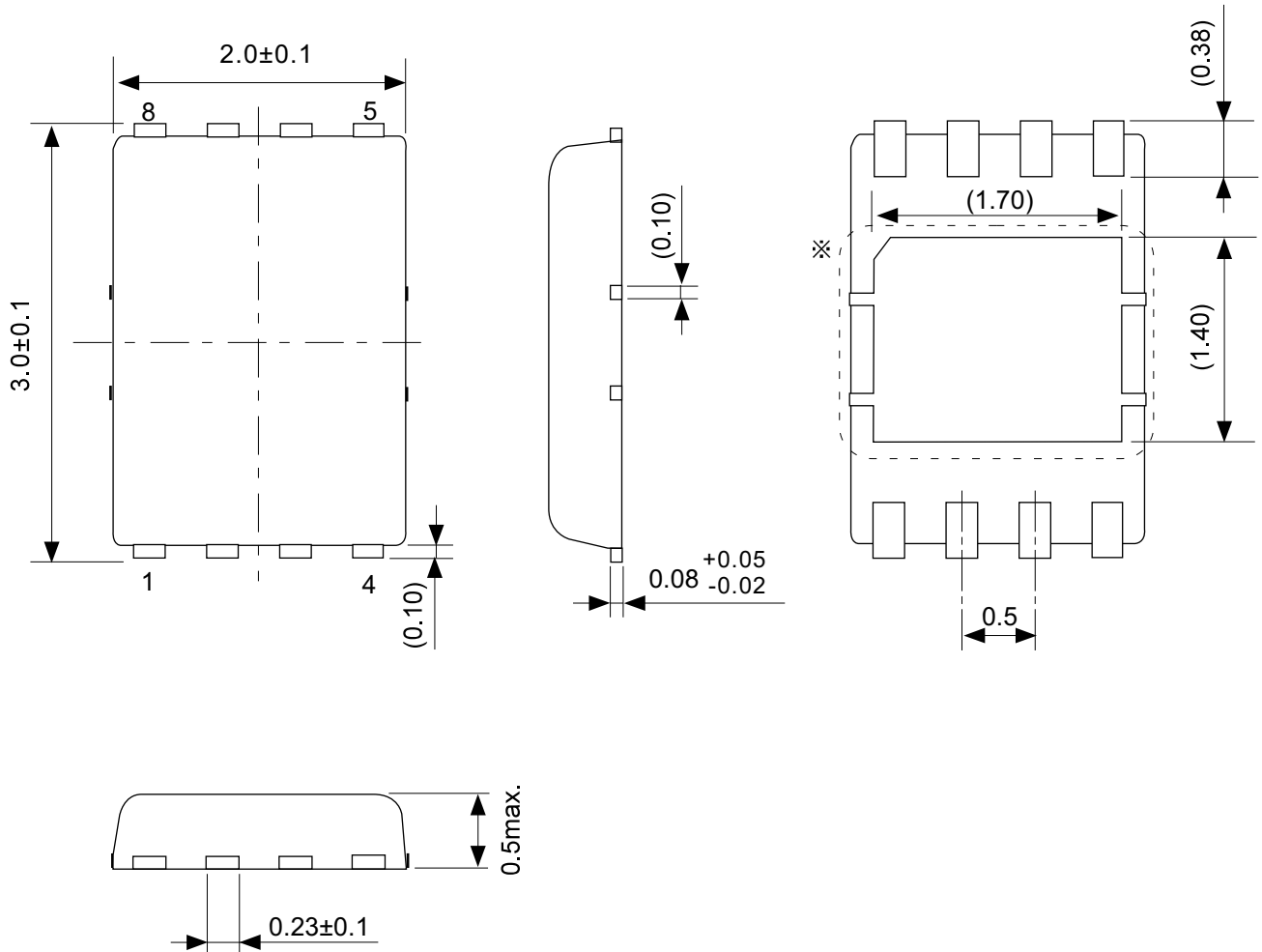

※ The heat sink of back side has different electric potential depending on the product.  
 Confirm specifications of each product.  
 Do not use it as the function of electrode.

No. PP008-A-P-SD-2.0

TITLE	HSNT-8-A-PKG Dimensions
No.	PP008-A-P-SD-2.0
ANGLE	
UNIT	mm
<b>ABLIC Inc.</b>	

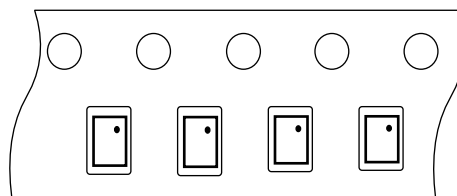
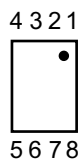
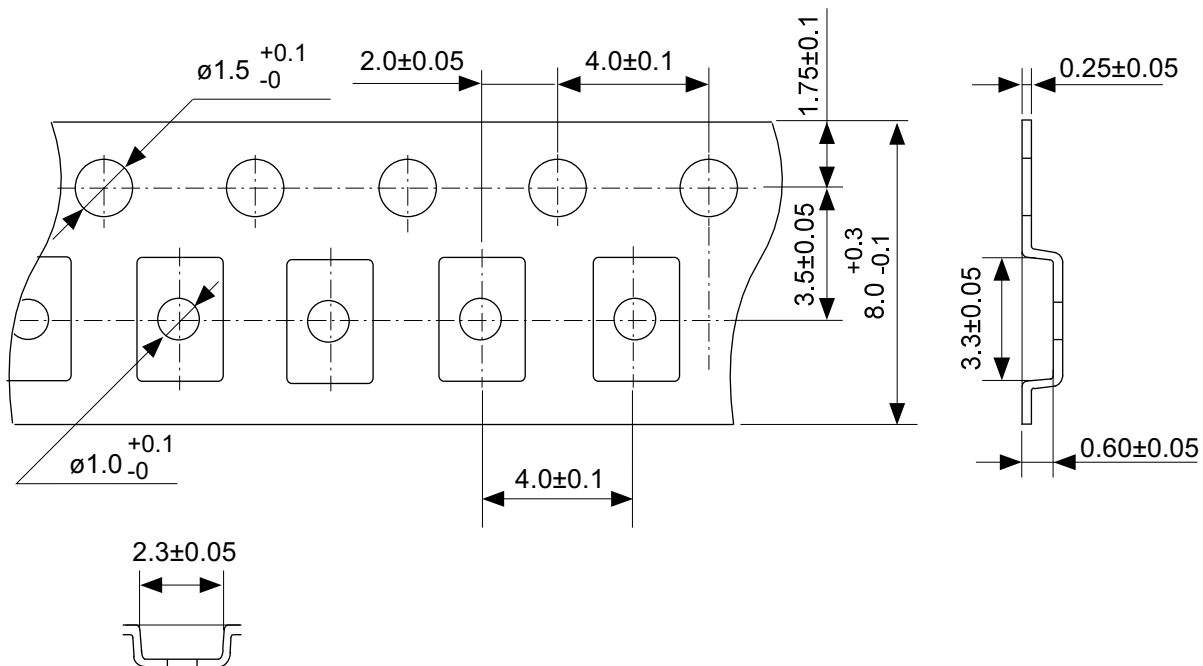

Feed direction

No. PP008-A-C-SD-1.0

TITLE	HSNT-8-A-Carrier Tape
No.	PP008-A-C-SD-1.0
ANGLE	
UNIT	mm
<b>ABLIC Inc.</b>	



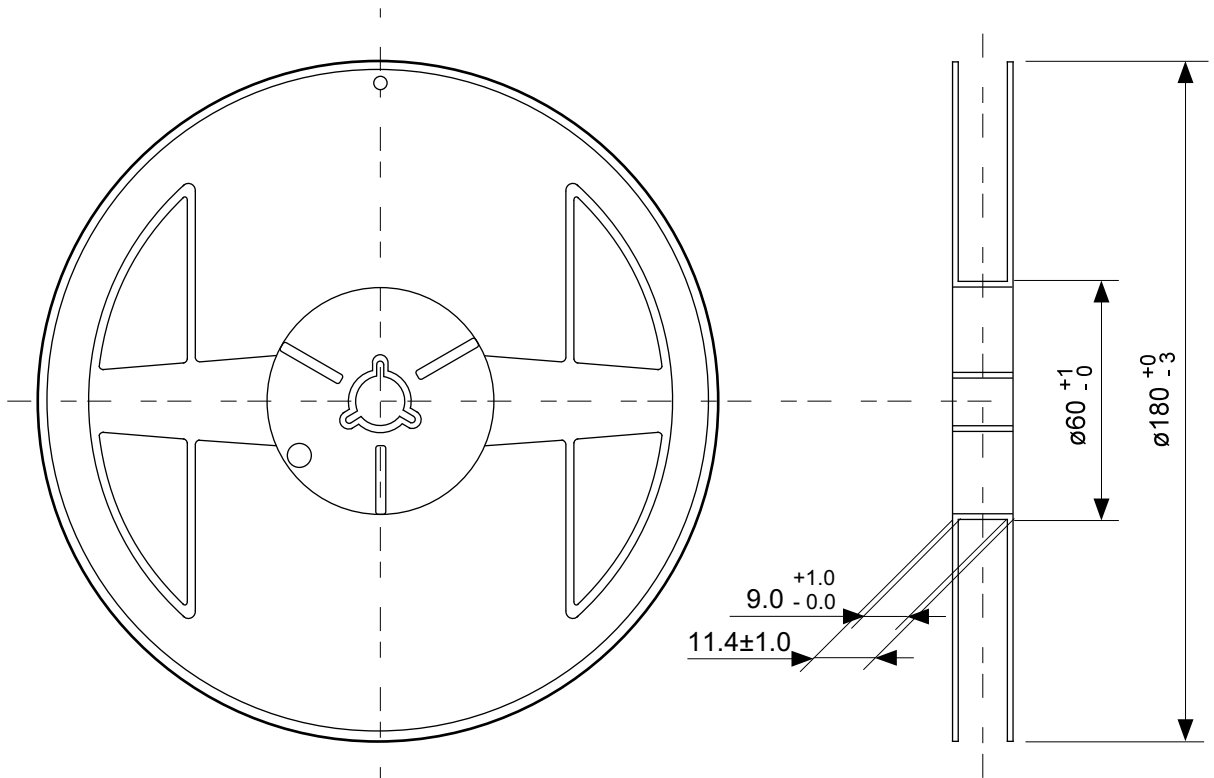

Enlarged drawing in the central part

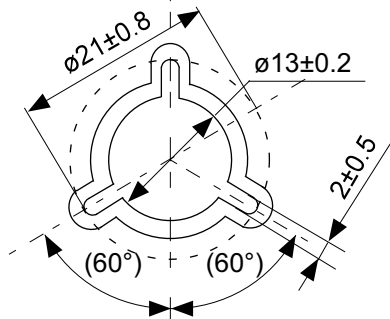

No. PP008-A-R-SD-2.0

TITLE	HSNT-8-A-Reel		
No.	PP008-A-R-SD-2.0		
ANGLE		QTY.	5,000
UNIT	mm		
<b>ABLIC Inc.</b>			

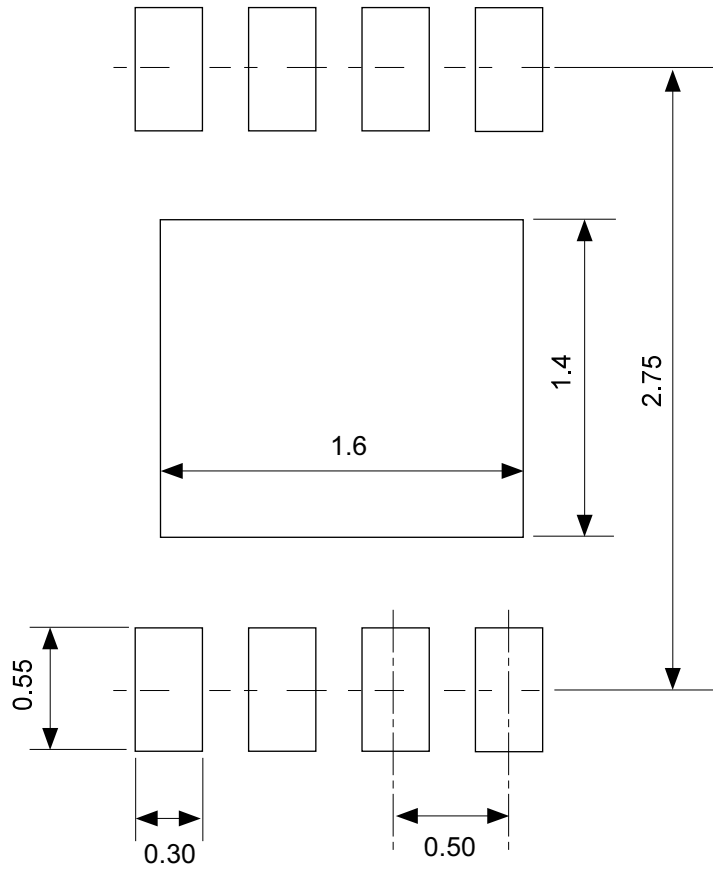

No. PP008-A-L-SD-1.0

TITLE	HSNT-8-A -Land Recommendation
No.	PP008-A-L-SD-1.0
ANGLE	
UNIT	mm
<b>ABLIC Inc.</b>	

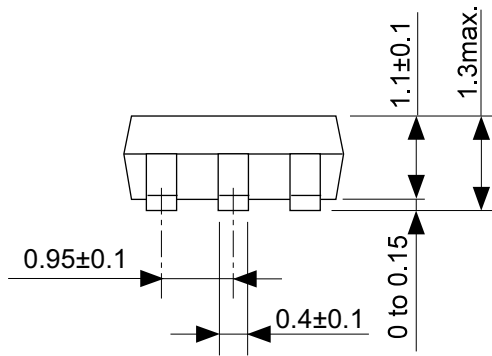
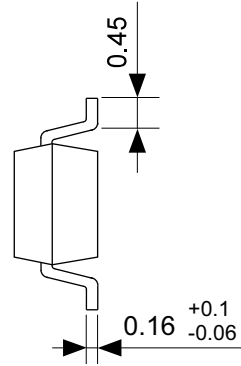
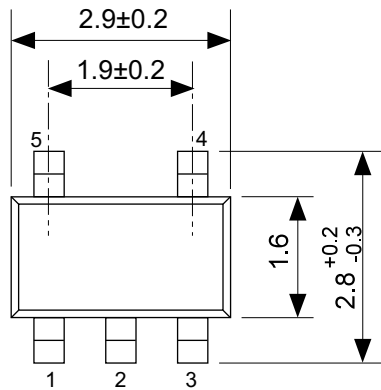

No. MP005-A-P-SD-1.3

TITLE	SOT235-A-PKG Dimensions
No.	MP005-A-P-SD-1.3
ANGLE	
UNIT	mm
<b>ABLIC Inc.</b>	

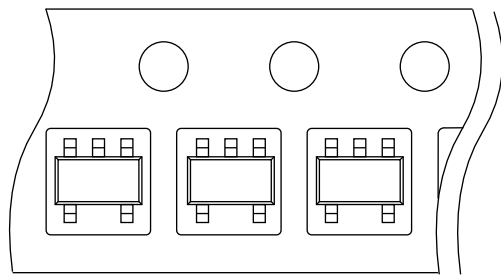
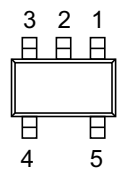
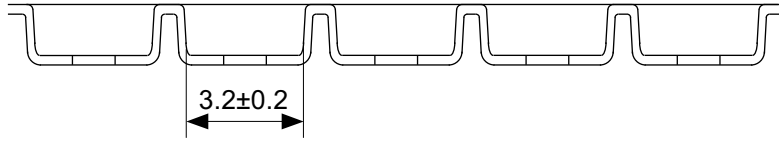
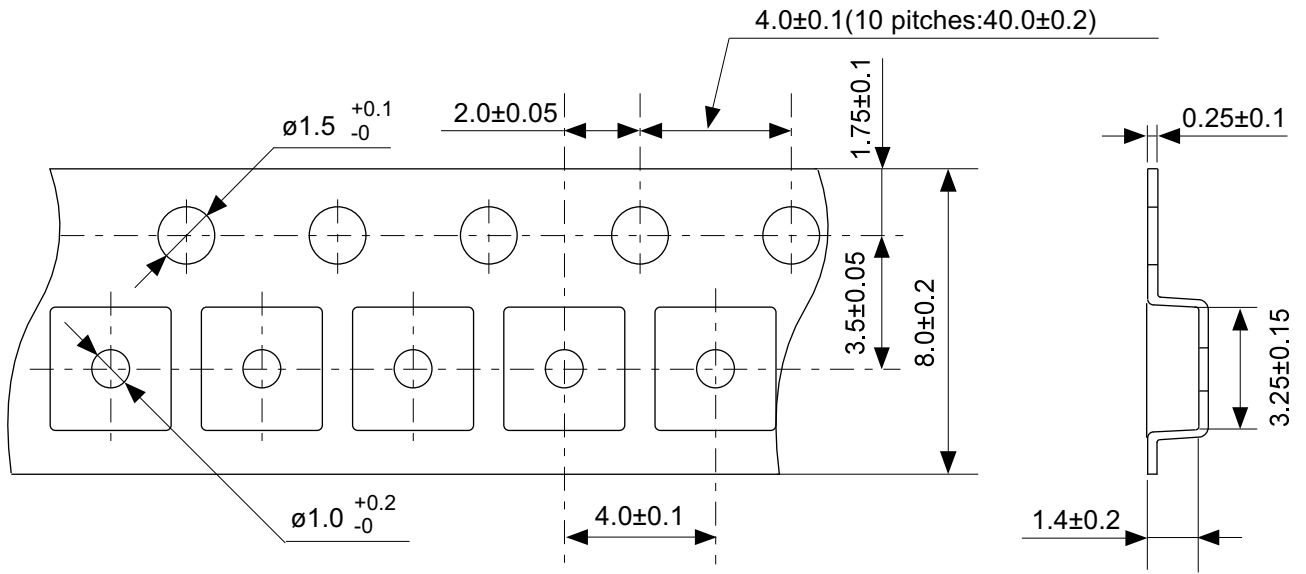

→  
Feed direction

No. MP005-A-C-SD-2.1

TITLE	SOT235-A-Carrier Tape
No.	MP005-A-C-SD-2.1
ANGLE	
UNIT	mm

**ABLIC Inc.**

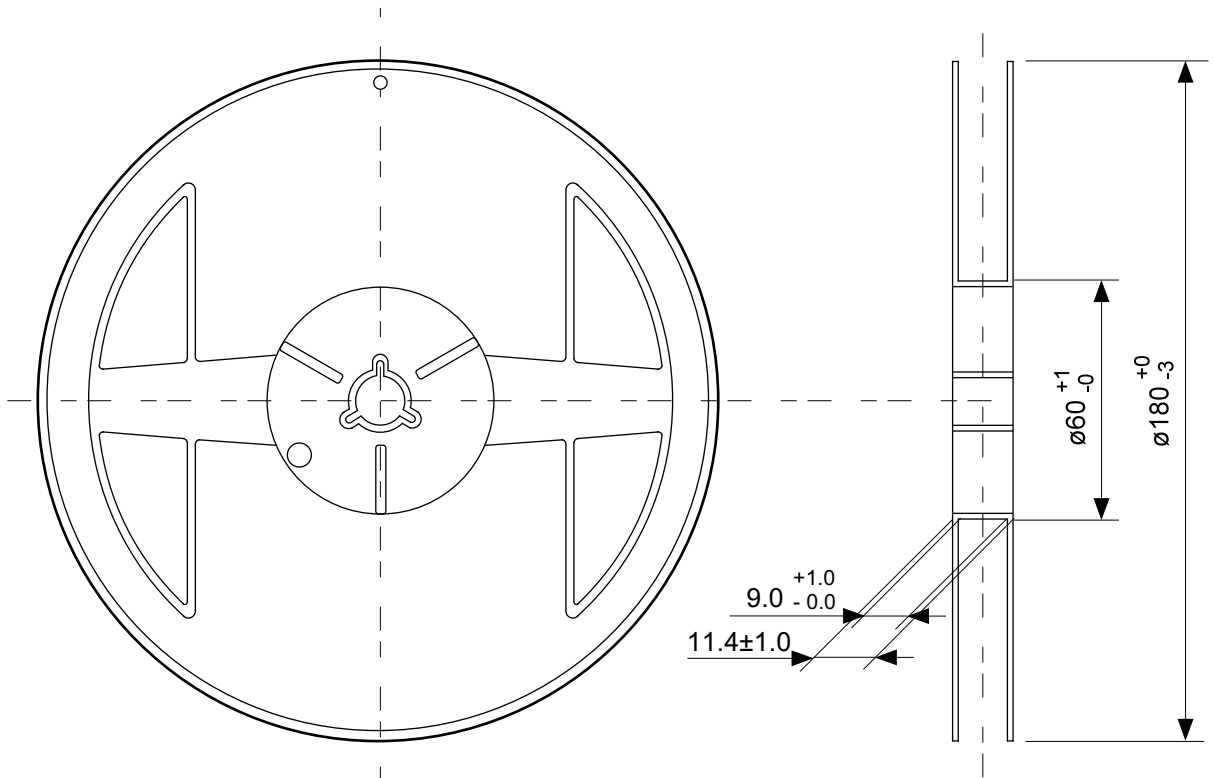

Enlarged drawing in the central part

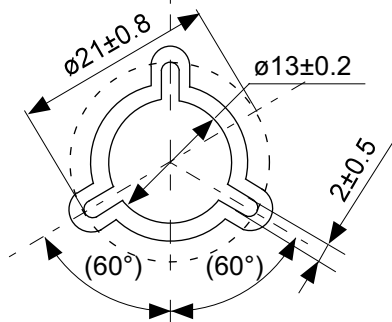

No. MP005-A-R-SD-2.0

TITLE	SOT235-A-Reel		
No.	MP005-A-R-SD-2.0		
ANGLE		QTY.	3,000
UNIT	mm		
<b>ABLIC Inc.</b>			

## Disclaimers (Handling Precautions)

1. All the information described herein (product data, specifications, figures, tables, programs, algorithms and application circuit examples, etc.) is current as of publishing date of this document and is subject to change without notice.
2. The circuit examples and the usages described herein are for reference only, and do not guarantee the success of any specific mass-production design.  
ABLIC Inc. is not liable for any losses, damages, claims or demands caused by the reasons other than the products described herein (hereinafter "the products") or infringement of third-party intellectual property right and any other right due to the use of the information described herein.
3. ABLIC Inc. is not liable for any losses, damages, claims or demands caused by the incorrect information described herein.
4. Be careful to use the products within their ranges described herein. Pay special attention for use to the absolute maximum ratings, operation voltage range and electrical characteristics, etc.  
ABLIC Inc. is not liable for any losses, damages, claims or demands caused by failures and / or accidents, etc. due to the use of the products outside their specified ranges.
5. Before using the products, confirm their applications, and the laws and regulations of the region or country where they are used and verify suitability, safety and other factors for the intended use.
6. When exporting the products, comply with the Foreign Exchange and Foreign Trade Act and all other export-related laws, and follow the required procedures.
7. The products are strictly prohibited from using, providing or exporting for the purposes of the development of weapons of mass destruction or military use. ABLIC Inc. is not liable for any losses, damages, claims or demands caused by any provision or export to the person or entity who intends to develop, manufacture, use or store nuclear, biological or chemical weapons or missiles, or use any other military purposes.
8. The products are not designed to be used as part of any device or equipment that may affect the human body, human life, or assets (such as medical equipment, disaster prevention systems, security systems, combustion control systems, infrastructure control systems, vehicle equipment, traffic systems, in-vehicle equipment, aviation equipment, aerospace equipment, and nuclear-related equipment), excluding when specified for in-vehicle use or other uses by ABLIC, Inc. Do not apply the products to the above listed devices and equipments.  
ABLIC Inc. is not liable for any losses, damages, claims or demands caused by unauthorized or unspecified use of the products.
9. In general, semiconductor products may fail or malfunction with some probability. The user of the products should therefore take responsibility to give thorough consideration to safety design including redundancy, fire spread prevention measures, and malfunction prevention to prevent accidents causing injury or death, fires and social damage, etc. that may ensue from the products' failure or malfunction.  
The entire system in which the products are used must be sufficiently evaluated and judged whether the products are allowed to apply for the system on customer's own responsibility.
10. The products are not designed to be radiation-proof. The necessary radiation measures should be taken in the product design by the customer depending on the intended use.
11. The products do not affect human health under normal use. However, they contain chemical substances and heavy metals and should therefore not be put in the mouth. The fracture surfaces of wafers and chips may be sharp. Be careful when handling these with the bare hands to prevent injuries, etc.
12. When disposing of the products, comply with the laws and ordinances of the country or region where they are used.
13. The information described herein contains copyright information and know-how of ABLIC Inc. The information described herein does not convey any license under any intellectual property rights or any other rights belonging to ABLIC Inc. or a third party. Reproduction or copying of the information from this document or any part of this document described herein for the purpose of disclosing it to a third-party is strictly prohibited without the express permission of ABLIC Inc.
14. For more details on the information described herein or any other questions, please contact ABLIC Inc.'s sales representative.
15. This Disclaimers have been delivered in a text using the Japanese language, which text, despite any translations into the English language and the Chinese language, shall be controlling.

2.4-2019.07