

The S-25C010A/020A/040A H series devices are high-temperature operation SPI serial E²PROMs for automotive components. The S-25C010A/020A/040A H series has the capacity of 1 K-bit, 2 K-bit, and 4 K-bit, and the organization is 128 words × 8-bit, 256 words × 8-bit, and 512 words × 8-bit, respectively.

Page write and sequential read are available.

Caution Before using the product in automobile control unit or medical equipment, contact to ABLIC Inc. is indispensable.

■ Features

- Operating voltage range: Read 2.5 V to 5.5 V
 Write 2.5 V to 5.5 V
- Operation frequency: 6.5 MHz (4.5 V to 5.5 V)
- Write time: 4.0 ms max.
- SPI mode (0, 0) and (1, 1)
- Page write: 16 bytes / page
- Sequential read
- Monitors write to the memory by a status register
- Write protect: Software, Hardware
 Protect area: 25%, 50%, 100%
- Function to prevent malfunction by monitoring clock pulse
- Write protect function during the low power supply voltage
- CMOS schmitt input (\overline{CS} , \overline{SCK} , \overline{SI} , \overline{WP} , \overline{HOLD})
- Endurance: 10^6 cycles/word*¹ (Ta = +85°C)
 8×10^5 cycles/word*¹ (Ta = +105°C)
- Data retention: 100 years (Ta = +25°C)
 50 years (Ta = +105°C)
- Memory capacitance: S-25C010A 1 K-bit
 S-25C020A 2 K-bit
 S-25C040A 4 K-bit
- Initial delivery state: FFh, BP1 = 0, BP0 = 0
- Operation temperature range: Ta = -40°C to +105°C
- Lead-free (Sn 100%), halogen-free
- AEC-Q100 qualified*²

*1. For each address (Word: 8-bit)

*2. Contact our sales office for details.

■ Packages

- 8-Pin SOP (JEDEC)
- 8-Pin TSSOP
- TMSOP-8

Pin Configurations

1. 8-Pin SOP (JEDEC)

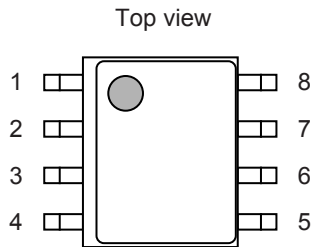

Figure 1

S-25C010A0H-J8T2UD
S-25C020A0H-J8T2UD
S-25C040A0H-J8T2UD

Table 1

Pin No.	Symbol	Description
1	\overline{CS}^{*1}	Chip select input
2	SO	Serial data output
3	\overline{WP}^{*1}	Write protect input
4	GND	Ground
5	SI ^{*1}	Serial data input
6	SCK ^{*1}	Serial clock input
7	\overline{HOLD}^{*1}	Hold input
8	VCC	Power supply

2. 8-Pin TSSOP

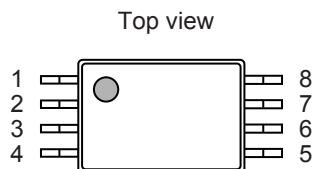

Figure 2

S-25C010A0H-T8T2UD
S-25C020A0H-T8T2UD
S-25C040A0H-T8T2UD

Table 2

Pin No.	Symbol	Description
1	\overline{CS}^{*1}	Chip select input
2	SO	Serial data output
3	\overline{WP}^{*1}	Write protect input
4	GND	Ground
5	SI ^{*1}	Serial data input
6	SCK ^{*1}	Serial clock input
7	\overline{HOLD}^{*1}	Hold input
8	VCC	Power supply

3. TMSOP-8

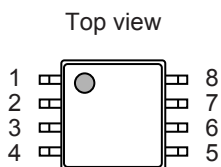

Figure 3

S-25C010A0H-K8T2UD
S-25C020A0H-K8T2UD
S-25C040A0H-K8T2UD

Table 3

Pin No.	Symbol	Description
1	\overline{CS}^{*1}	Chip select input
2	SO	Serial data output
3	\overline{WP}^{*1}	Write protect input
4	GND	Ground
5	SI ^{*1}	Serial data input
6	SCK ^{*1}	Serial clock input
7	\overline{HOLD}^{*1}	Hold input
8	VCC	Power supply

*1. Do not use it in high impedance.

Remark See Dimensions for details of the package drawings.

■ Block Diagram

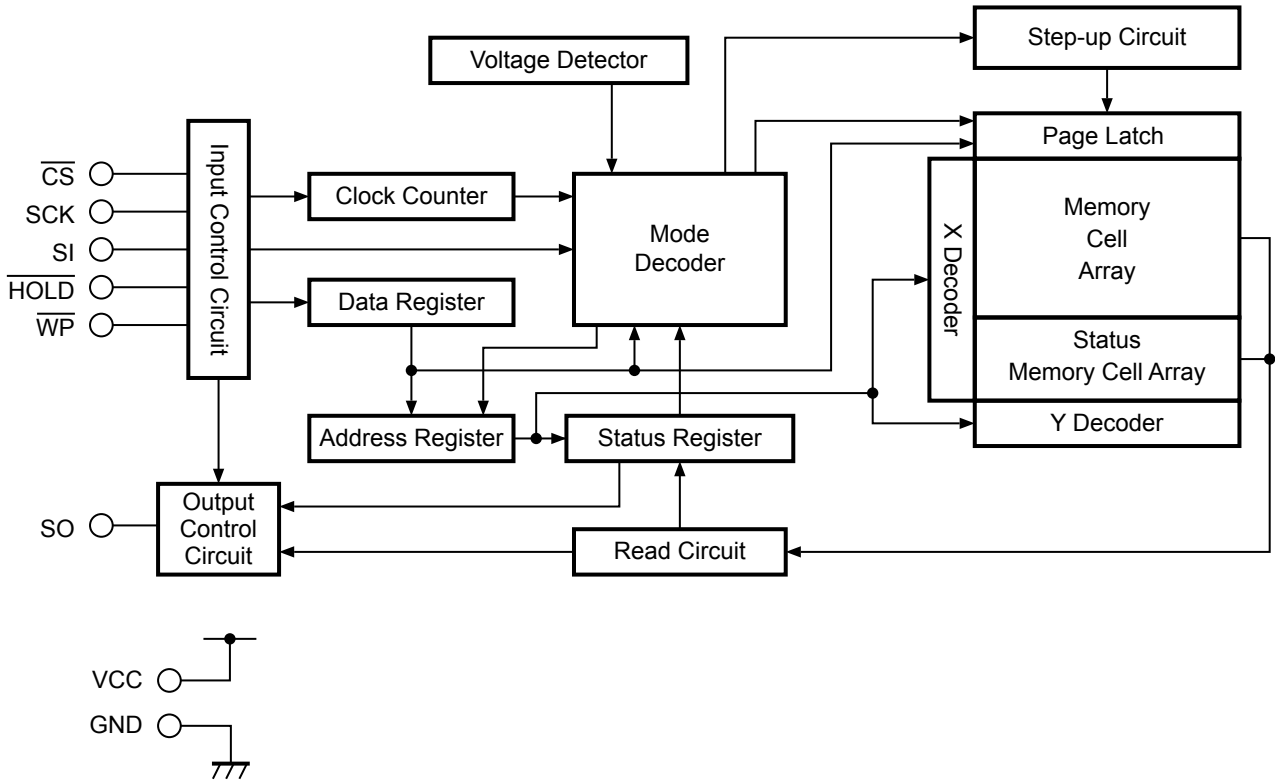

Figure 4

■ AEC-Q100 Qualified

This IC supports AEC-Q100 for operation temperature grade 2.
Contact our sales office for details of AEC-Q100 reliability specification.

■ Absolute Maximum Ratings

Table 4

Item	Symbol	Absolute Maximum Rating	Unit
Power supply voltage	V _{CC}	-0.3 to +7.0	V
Input voltage	V _{IN}	-0.3 to +7.0	V
Output voltage	V _{OUT}	-0.3 to V _{CC} + 0.3	V
Operating ambient temperature	T _{opr}	-40 to +105	°C
Storage temperature	T _{stg}	-65 to +150	°C

Caution The absolute maximum ratings are rated values exceeding which the product could suffer physical damage. These values must therefore not be exceeded under any conditions.

■ Recommended Operating Conditions

Table 5

Item	Symbol	Condition	Ta = -40°C to +105°C		Unit
			Min.	Max.	
Power supply voltage	V _{CC}	Read operation	2.5	5.5	V
		Write operation	2.5	5.5	V
High level input voltage	V _{IH}	V _{CC} = 2.5 V to 5.5 V	0.7 × V _{CC}	V _{CC} + 1.0	V
Low level input voltage	V _{IL}	V _{CC} = 2.5 V to 5.5 V	-0.3	0.3 × V _{CC}	V

■ Pin Capacitance

Table 6

(Ta = +25°C, f = 1.0 MHz, V_{CC} = 5 V)

Item	Symbol	Condition	Min.	Max.	Unit
Input capacitance	C _{IN}	V _{IN} = 0 V (CS, SCK, SI, WP, HOLD)	-	8	pF
Output capacitance	C _{OUT}	V _{OUT} = 0 V (SO)	-	10	pF

■ Endurance

Table 7

Item	Symbol	Operating Ambient Temperature	Min.	Max.	Unit
Endurance	N _w	-40°C to +85°C	10 ⁶	-	cycles / word ^{*1}
		-40°C to +105°C	8 × 10 ⁵	-	cycles / word ^{*1}

*1. For each address (Word: 8 bits)

■ Data Retention

Table 8

Item	Symbol	Operation Ambient Temperature	Min.	Max.	Unit
Data retention	-	+25°C	100	-	year
		-40°C to +105°C	50	-	year

**105°C OPERATION SPI SERIAL E²PROM FOR AUTOMOTIVE
S-25C010A/020A/040A H Series**

Rev.3.0_01_c

■ DC Electrical Characteristics

Table 9

Item	Symbol	Condition	Ta = -40°C to +105°C						Unit
			V _{CC} = 2.5 V to 3.0 V f _{SCK} = 3.5 MHz		V _{CC} = 3.0 V to 4.5 V f _{SCK} = 5.0 MHz		V _{CC} = 4.5 V to 5.5 V f _{SCK} = 6.5 MHz		
			Min.	Max.	Min.	Max.	Min.	Max.	
Current consumption (READ)	I _{CC1}	No load at SO pin	-	1.5	-	2.0	-	2.5	mA

Table 10

Item	Symbol	Condition	Ta = -40°C to +105°C						Unit
			V _{CC} = 2.5 V to 3.0 V f _{SCK} = 3.5 MHz		V _{CC} = 3.0 V to 4.5 V f _{SCK} = 5.0 MHz		V _{CC} = 4.5 V to 5.5 V f _{SCK} = 6.5 MHz		
			Min.	Max.	Min.	Max.	Min.	Max.	
Current consumption (WRITE)	I _{CC2}	No load at SO pin	-	2.0	-	2.5	-	3.0	mA

Table 11

Item	Symbol	Condition	Ta = -40°C to +105°C				Unit
			V _{CC} = 2.5 V to 4.5 V		V _{CC} = 4.5 V to 5.5 V		
			Min.	Max.	Min.	Max.	
Standby current consumption	I _{SB}	CS = V _{CC} , SO = Open Other inputs are V _{CC} or GND	-	8.0	-	10.0	μA
Input leakage current	I _{LI}	V _{IN} = GND to V _{CC}	-	2.0	-	2.0	μA
Output leakage current	I _{LO}	V _{OUT} = GND to V _{CC}	-	2.0	-	2.0	μA
Low level output voltage	V _{OL1}	I _{OL} = 2.0 mA	-	-	-	0.4	V
	V _{OL2}	I _{OL} = 1.5 mA	-	0.4	-	0.4	V
High level output voltage	V _{OH1}	I _{OH} = -2.0 mA	-	-	0.8 × V _{CC}	-	V
	V _{OH2}	I _{OH} = -0.4 mA	0.8 × V _{CC}	-	0.8 × V _{CC}	-	V

■ AC Electrical Characteristics

Table 12 Measurement Conditions

Input pulse voltage	$0.2 \times V_{CC}$ to $0.8 \times V_{CC}$
Output reference voltage	$0.5 \times V_{CC}$
Output load	100 pF

Table 13

Item	Symbol	Ta = -40°C to +105°C						Unit
		V _{CC} = 2.5 V to 5.5 V		V _{CC} = 3.0 V to 5.5 V		V _{CC} = 4.5 V to 5.5 V		
		Min.	Max.	Min.	Max.	Min.	Max.	
SCK clock frequency	f _{SCK}	–	3.5	–	5.0	–	6.5	MHz
\overline{CS} setup time during \overline{CS} falling	t _{CSS.CL}	90	–	90	–	65	–	ns
\overline{CS} setup time during \overline{CS} rising	t _{CSS.CH}	90	–	90	–	65	–	ns
\overline{CS} deselect time	t _{CDS}	160	–	140	–	110	–	ns
\overline{CS} hold time during \overline{CS} falling	t _{C_{SH}.CL}	90	–	90	–	65	–	ns
\overline{CS} hold time during \overline{CS} rising	t _{C_{SH}.CH}	90	–	90	–	65	–	ns
SCK clock time “H” *1	t _{HIGH}	125	–	95	–	65	–	ns
SCK clock time “L” *1	t _{LOW}	125	–	95	–	65	–	ns
Rising time of SCK clock *2	t _{RSK}	–	1	–	1	–	1	μs
Falling time of SCK clock *2	t _{FSK}	–	1	–	1	–	1	μs
SI data input setup time	t _{DS}	20	–	20	–	20	–	ns
SI data input hold time	t _{DH}	30	–	30	–	30	–	ns
SCK “L” hold time during \overline{HOLD} rising	t _{SKH.HH}	70	–	70	–	45	–	ns
SCK “L” hold time during \overline{HOLD} falling	t _{SKH.HL}	40	–	40	–	30	–	ns
SCK “L” setup time during \overline{HOLD} falling	t _{SKS.HL}	0	–	0	–	0	–	ns
SCK “L” setup time during \overline{HOLD} rising	t _{SKS.HH}	0	–	0	–	0	–	ns
Disable time of SO output *2	t _{OZ}	–	100	–	100	–	75	ns
Delay time of SO output	t _{OD}	–	120	–	90	–	60	ns
Hold time of SO output	t _{OH}	0	–	0	–	0	–	ns
Rising time of SO output *2	t _{RO}	–	80	–	70	–	50	ns
Falling time of SO output *2	t _{FO}	–	80	–	70	–	50	ns
Disable time of SO output during \overline{HOLD} falling *2	t _{OZ.HL}	–	100	–	100	–	75	ns
Delay time of SO output during \overline{HOLD} rising *2	t _{OD.HH}	–	80	–	80	–	60	ns
\overline{WP} setup time	t _{WS1}	0	–	0	–	0	–	ns
\overline{WP} hold time	t _{WH1}	0	–	0	–	0	–	ns
\overline{WP} release / setup time	t _{WS2}	0	–	0	–	0	–	ns
\overline{WP} release / hold time	t _{WH2}	150	–	150	–	100	–	ns

*1. The clock cycle of the SCK clock (frequency f_{SCK}) is 1/f_{SCK} μs. This clock cycle is determined by a combination of several AC characteristics. Note that the clock cycle cannot be set as (1/f_{SCK}) = t_{LOW} (Min.) + t_{HIGH} (Min.) by minimizing the SCK clock cycle time.

*2. These are values of sample and not 100% tested.

Table 14

Item	Symbol	Ta = -40°C to +105°C		Unit
		V _{CC} = 2.5 V to 5.5 V		
		Min.	Max.	
Write time	t _{PR}	-	4.0	ms

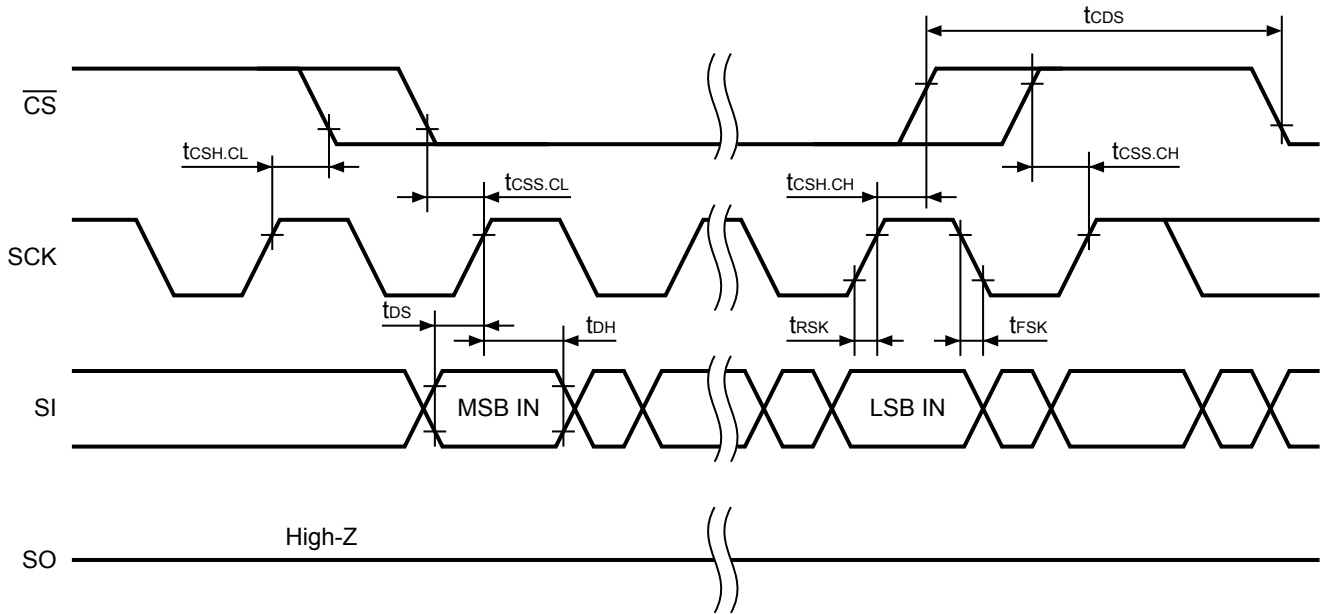

Figure 5 Serial Input Timing

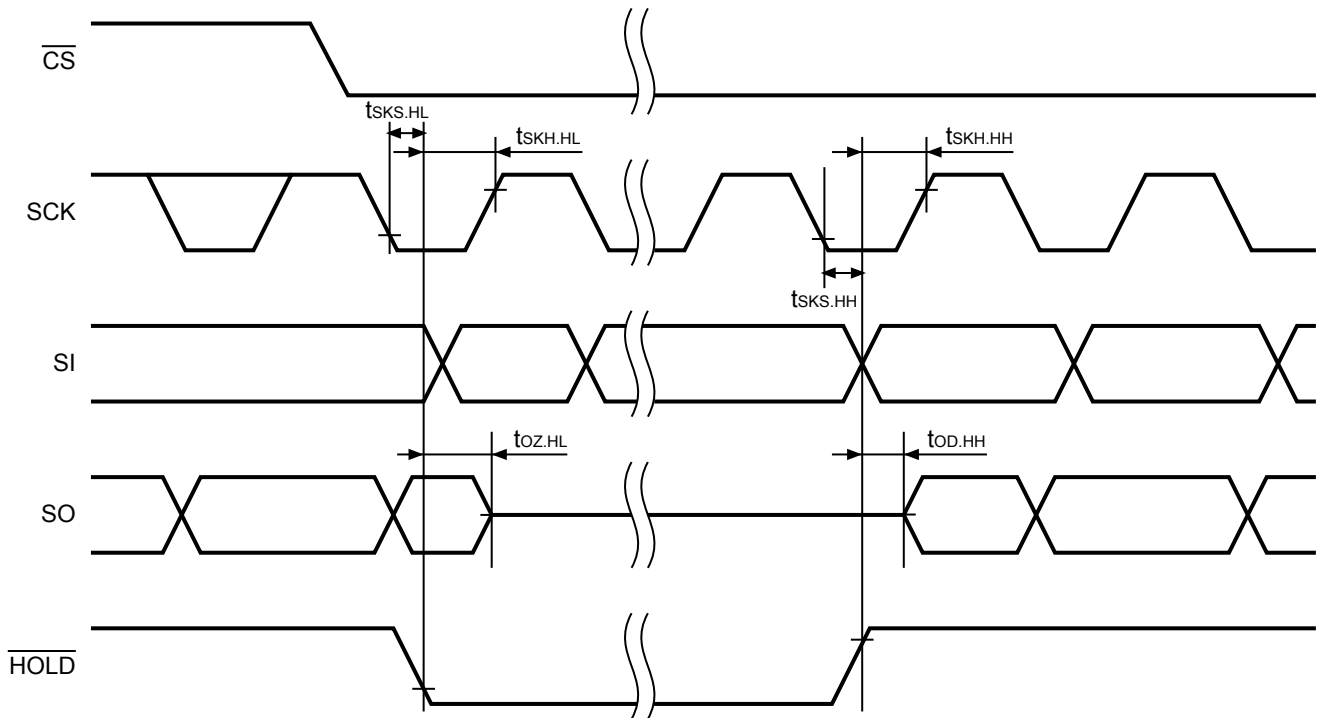

Figure 6 Hold Timing

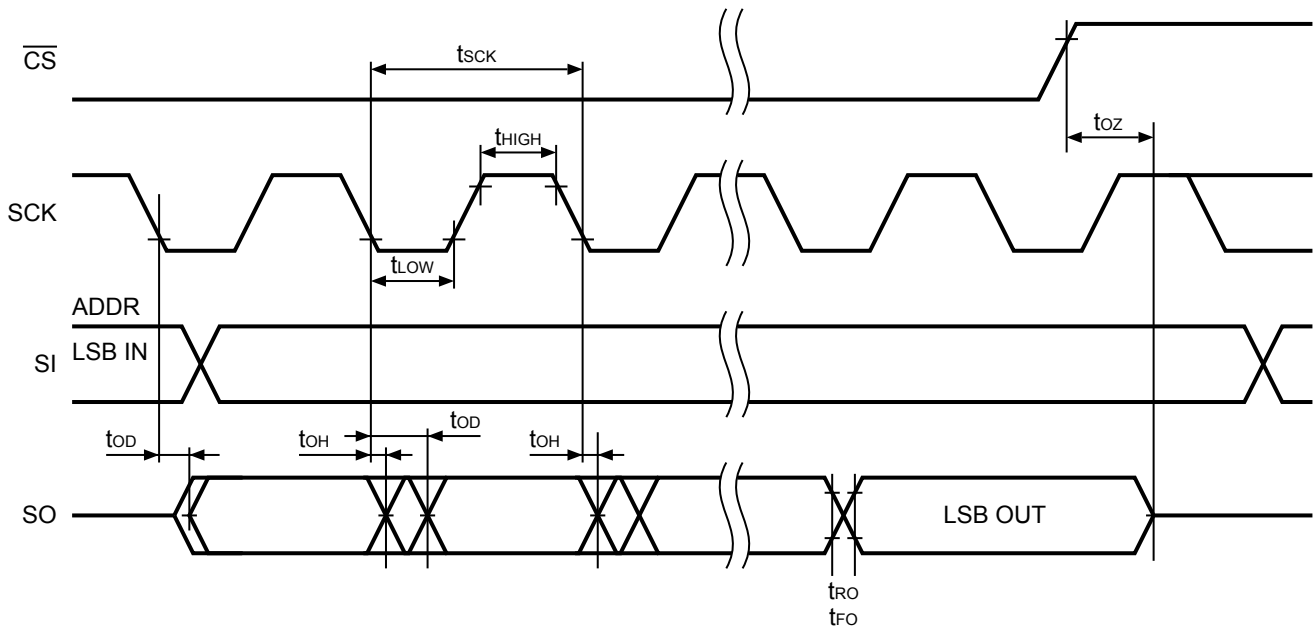

Figure 7 Serial Output Timing

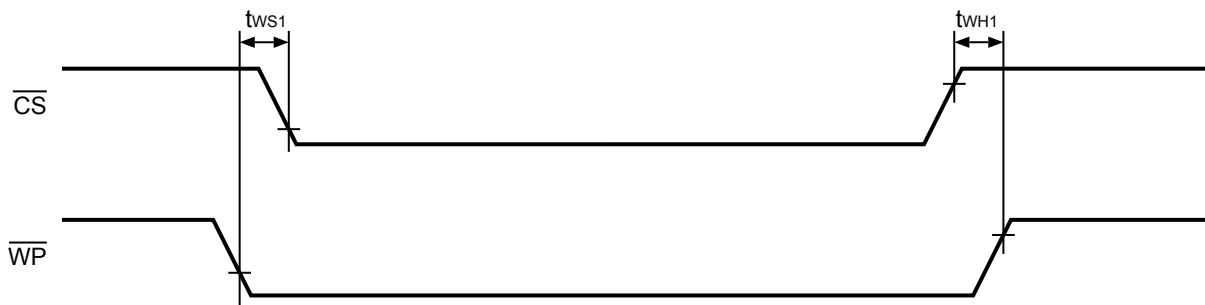

Figure 8 Valid Timing in Write Protect

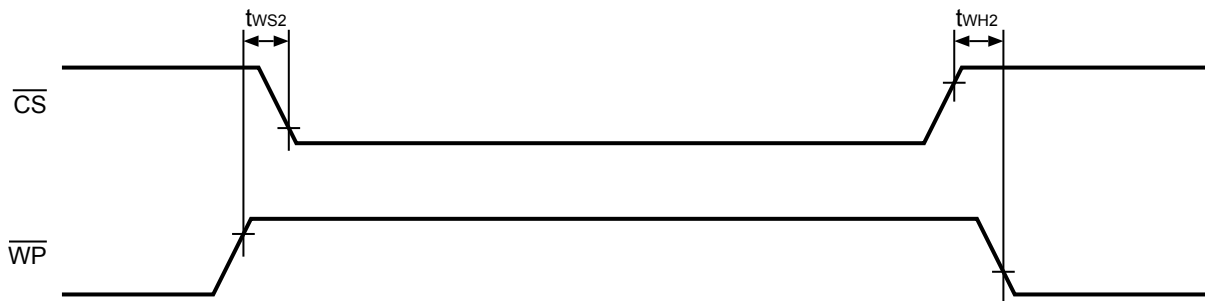

Figure 9 Invalid Timing in Write Protect

■ Pin Function

1. $\overline{\text{CS}}$ (Chip select input) pin

This is an input pin to set a chip in the select status. In the “H” input level, the device is in the non-select status and its output is high impedance. The device is in standby as long as it is not in Write inside. The device goes in active by setting the chip select to “L”. Input any instruction code after power-on and a falling of chip select.

2. SI (Serial data input) pin

This pin is to input serial data. This pin receives an instruction code, an address and Write data. This pin latches data at rising edge of serial clock.

3. SO (Serial data output) pin

This pin is to output serial data. The data output changes at falling edge of serial clock.

4. SCK (Serial clock input) pin

This is a clock input pin to set the timing of serial data. An instruction code, an address and Write data are received at a rising edge of clock. Data is output at falling edge of clock.

5. $\overline{\text{WP}}$ (Write protect input) pin

This is an input pin to protect memory data when Write instruction (WRITE, WRSR) is being input. By setting this pin to “L”, the WEL bit in the status register is set to “L”. Therefore S-25C010A/020A/040A does not Write to the E²PROM, however, it accepts other instructions. Fix this pin “H” or “L” not to set it in the floating state. Refer to “■ Protect Operation” for details.

6. $\overline{\text{HOLD}}$ (HOLD input) pin

This pin is used to pause serial communications without setting the device in the non-select status. In the hold status, the serial output goes in high impedance, the serial input and the serial clock go in “Don’t care”. During the hold operation, be sure to set the device in active by setting the chip select ($\overline{\text{CS}}$ pin) to “L”. Refer to “■ Hold Operation” for details.

■ Initial Delivery State

Initial delivery state of all addresses is “FFh”.

Moreover, initial delivery state of the status register nonvolatile memory is as follows.

- BP1 = 0
- BP0 = 0

■ Instruction Setting

Tables 15 and 16 are the lists of instructions for the S-25C010A/020A/040A. The instruction is able to be input by changing the \overline{CS} pin “H” to “L”. Input the instruction in the MSB first. Each instruction code is organized with 1-byte as shown below. If the S-25C010A/020A/040A receives any invalid instruction code, the device goes in the non-select status.

1. S-25C010A/020A

Table 15 Instruction Set

Instruction	Operation	Instruction code	Address	Data
		SCK input clock 1 to 8	SCK input clock 9 to 16	SCK input clock 17 to 24
WREN	Write enable	0000 X110	–	–
WRDI	Write disable	0000 X100	–	–
RDSR	Read the status register	0000 X101	b7 to b0 output ^{*1}	–
WRSR	Write in the status register	0000 X001	b7 to b0 input	–
READ	Read memory data	0000 X011	A7 ^{*2} to A0	D7 to D0 output ^{*3}
WRITE	Write memory data	0000 X010	A7 ^{*2} to A0	D7 to D0 input

*1. Sequential data reading is possible.

*2. In the S-25C010A, A7 = Don't care because the address range is A6 to A0.

*3. After outputting data in the specified address, data in the following address is output.

Remark X = Don't care.

2. S-25C040A

Table 16 Instruction Set

Instruction	Operation	Instruction code	Address	Data
		SCK input clock 1 to 8	SCK input clock 9 to 16	SCK input clock 17 to 24
WREN	Write enable	0000 X110	–	–
WRDI	Write disable	0000 X100	–	–
RDSR	Read the status register	0000 X101	b7 to b0 output ^{*1}	–
WRSR	Write in the status register	0000 X001	b7 to b0 input	–
READ	Read memory data	0000 [A8 ^{*2}]011	A7 to A0	D7 to D0 output ^{*3}
WRITE	Write memory data	0000 [A8 ^{*2}]010	A7 to A0	D7 to D0 input

*1. Sequential data reading is possible.

*2. In the S-25C040A, assign bit A8 in the address into the fifth bit in an instruction code.

*3. After outputting data in the specified address, data in the following address is output.

Remark X = Don't care.

■ Operation

1. Status register

The status register's organization is below. The status register can Write and Read by a specific instruction.

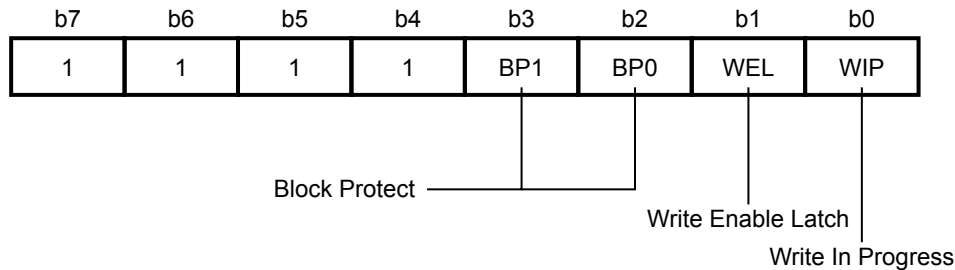

Figure 10 Organization of Status Register

The status/control bits of the status register are as follows.

1.1 BP1, BP0 (b3, b2) : Block protect

Bit BP1 and BP0 are composed of the nonvolatile bit. The area size of Software Protect with respect to WRITE instructions is defined by the BP1 and BP0 bits. Rewriting these bits is possible by the WRSR instruction. To protect the memory area against the WRITE instruction, set either or both of bit BP1 and BP0 to "1". Rewriting bit BP1 and BP0 is possible unless they are in Hardware Protect mode.

Refer to "■ Protect Operation" for details of "Block Protect".

1.2 WEL (b1) : Write enable latch

Bit WEL shows the status of internal Write Enable Latch. Bit WEL is set by the WREN instruction only. If bit WEL is "1", this is the status that Write Enable Latch is set. If bit WEL is "0", Write Enable Latch is in reset, so that the S-25C010A/020A/040A does not receive the WRITE or WRSR instruction. Bit WEL is reset after these operations;

- The power supply voltage is dropping
- Power-on
- After performing WRDI
- After the Write operation by the WRSR instruction
- After the Write operation by the WRITE instruction
- After setting the \overline{WP} pin to "L"

1.3 WIP (b0) : Write in progress

Bit WIP is a Read Only bit. It indicates whether the internal memory is in the Write operation or not by the WRITE or WRSR instruction. Bit WIP is "1" during the Write operation but "0" during any other status. **Figure 11** shows the usage example.

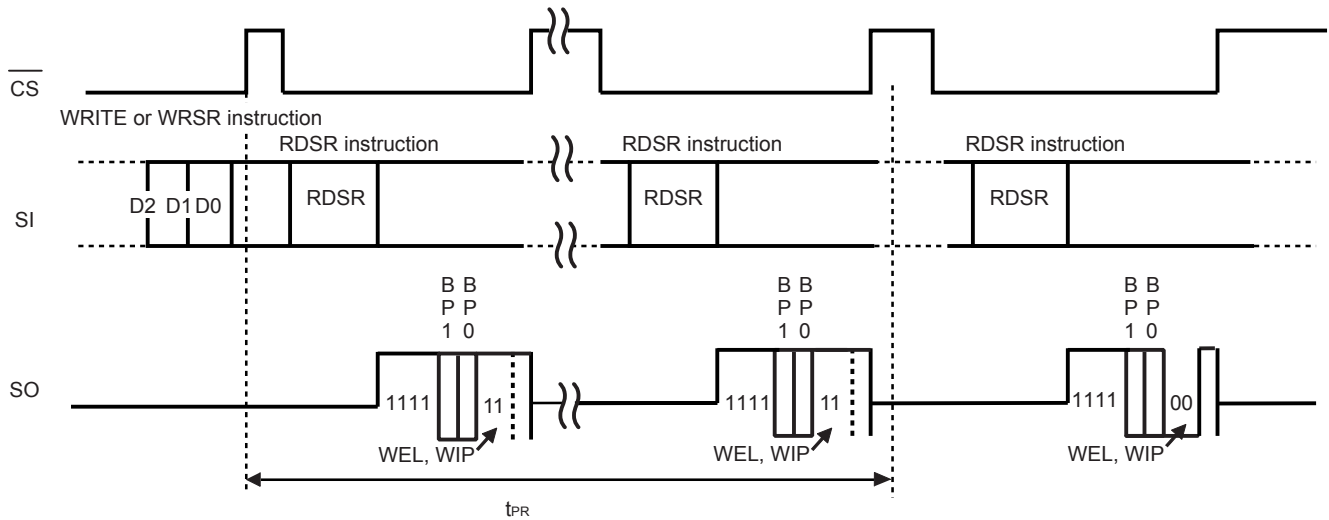
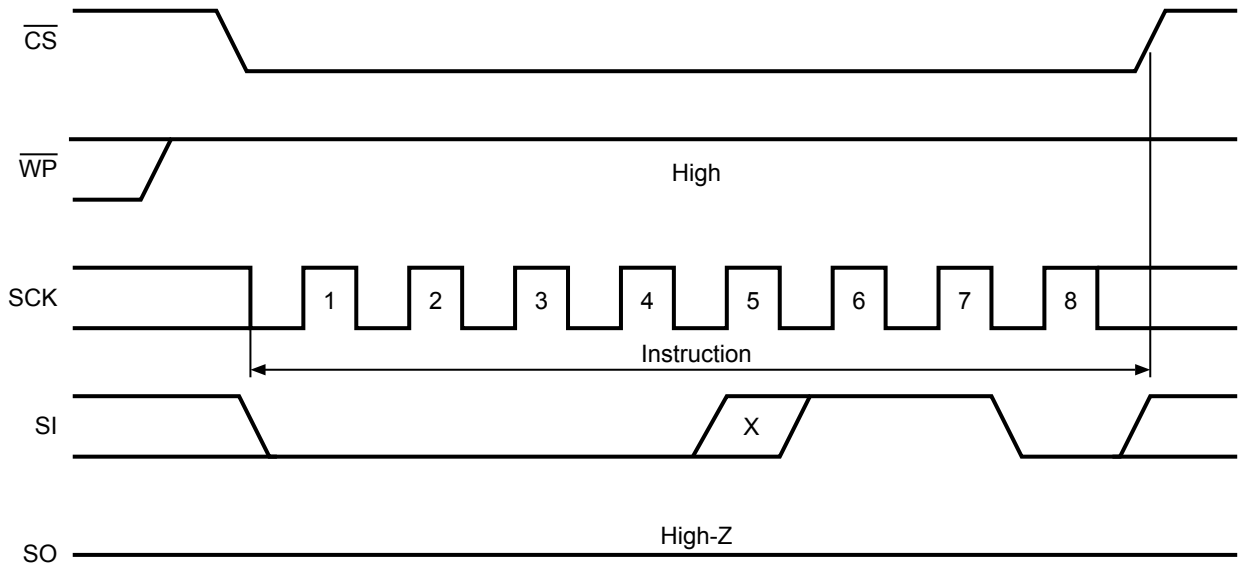

Figure 11 Usage Example of WEL, WIP Bits during Write

2. Write enable (WREN)

Before writing data (WRITE and WRSR), be sure to set bit Write Enable Latch (WEL). This instruction is to set bit WEL. Its operation is below.

After selecting the device by the chip select (\overline{CS}), input the instruction code from serial data input (SI). To set bit WEL, set the device in the non-select status by \overline{CS} at the 8th clock of the serial clock (SCK). To cancel the WREN instruction, input the clock different from a specified value (n = 8 clock) while \overline{CS} is in "L".



Remark X = Don't care.

Figure 12 WREN Operation

3. Write disable (WRDI)

The WRDI instruction is one of ways to reset bit Write Enable Latch (WEL). After selecting the device by the chip select (\overline{CS}), input the instruction code from serial data input (SI).

To reset bit WEL, set the device in the non-select status by \overline{CS} at the 8th clock of the serial clock. To cancel the WRDI instruction, input the clock different from a specified value (n = 8 clock) while \overline{CS} is in "L".

Bit WEL is reset after the operations shown below.

- The power supply voltage is dropping
- Power-on
- After performing WRDI
- After the completion of Write operation by the WRSR instruction
- After the completion of Write operation by the WRITE instruction
- After setting the \overline{WP} pin to "L"

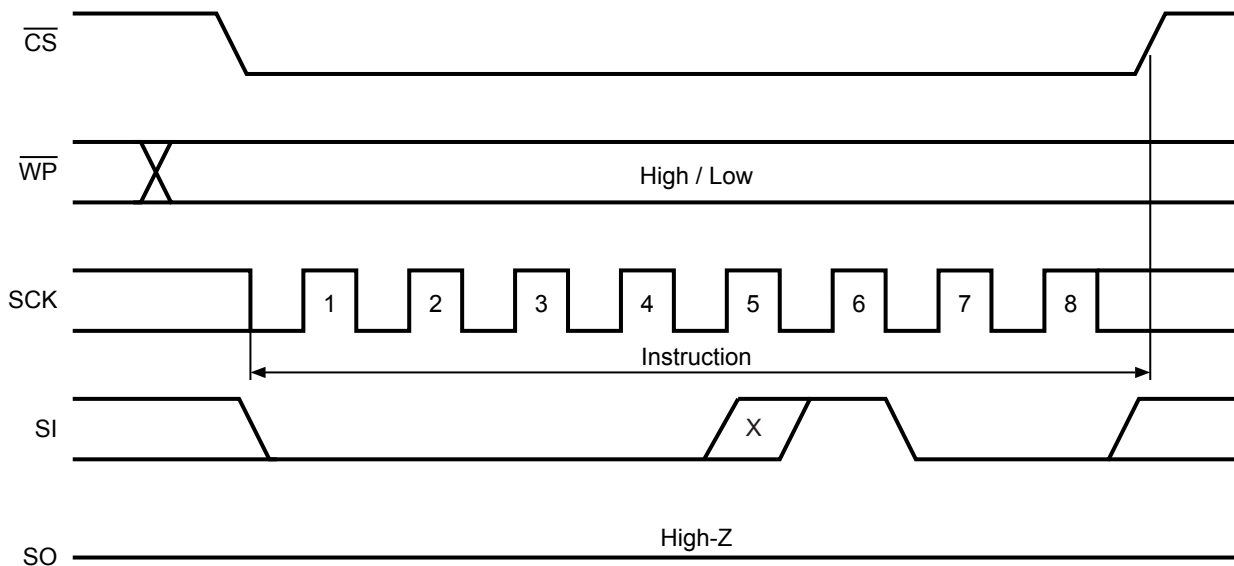

Remark X = Don't care.

Figure 13 WRDI Operation

4. Read the status register (RDSR)

Reading data in the status register is possible by the RDSR instruction. During the Write operation, it is possible to confirm the progress by checking bit WIP.

Set the chip select (\overline{CS}) "L" first. After that, input the instruction code from serial data input (SI). The status of bit in the status register is output from serial data output (SO). Sequential Read is available for the status register. To stop the Read cycle, set \overline{CS} to "H".

It is possible to read the status register always. The bits in it are valid and can be read by RDSR even in the Write cycle. The 2 bits WEL and WIP are updated during the write cycle. The updated nonvolatile bits BP1 and BP0 can be acquired by performing a new RDSR instruction after verifying the completion of the write cycle.

b7, b6, b5, and b4 are "1" when they are read by the RDSR instruction.

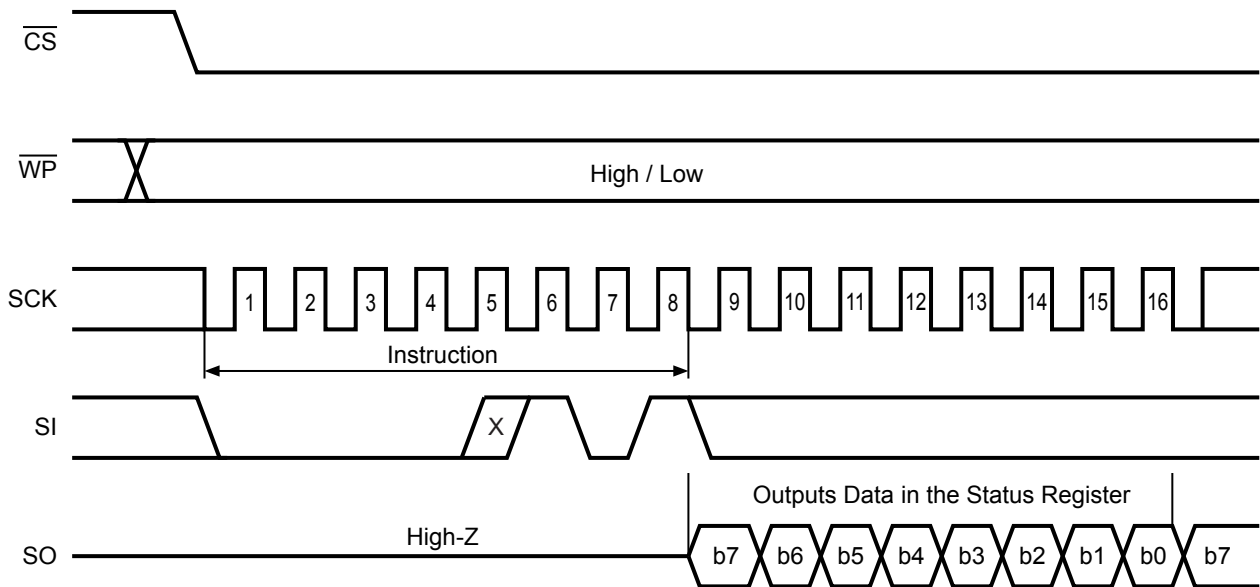

Remark X = Don't care.

Figure 14 RDSR Operation

5. Write in the status register (WRSR)

The values of status register (BP1, BP0) can be rewritten by inputting the WRSR instruction. But b7, b6, b5, b4, b1, b0 of status register cannot be rewritten. b7 to b4 are always "1" when reading the status register.

Before inputting the WRSR instruction, set bit WEL by the WREN instruction. The operation of WRSR is shown below.

Set the chip select (\overline{CS}) "L" first. After that, input the instruction code and data from serial data input (SI). To start WRSR Write (t_{PR}), set the chip select (\overline{CS}) to "H" after inputting data or before inputting a rising of the next serial clock. It is possible to confirm the operation status by reading the value of bit WIP during WRSR Write. Bit WIP is "1" during Write, "0" during any other status. Bit WEL is reset when Write is completed.

With the WRSR instruction, the values of BP1 and BP0; which determine the area size the users can handle as the Read Only memory; can be changed. When signal \overline{WP} is "L", however, the WRSR instruction is not be performed (Refer to "■ Protect Operation").

Bits BP1 and BP0 keep the value which is the one prior to the WRSR instruction during the WRSR instruction. The newly updated value is changed when the WRSR instruction has completed.

To cancel the WRSR instruction, input the clock different from a specified value ($n = 16$ clock) while \overline{CS} is in "L".

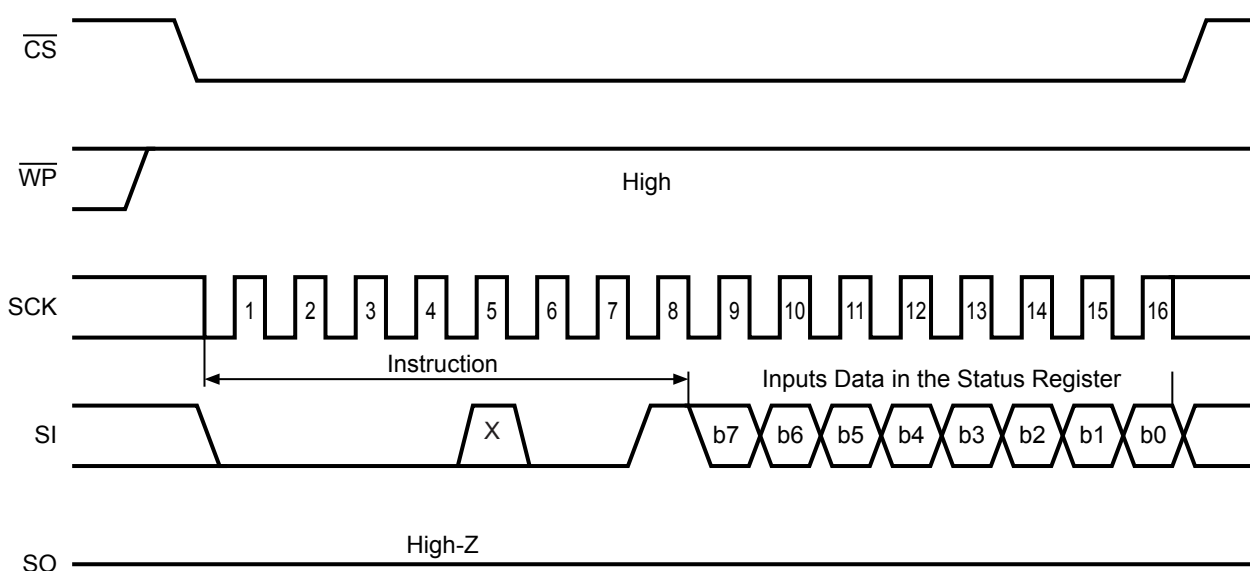

Remark X = Don't care.

Figure 15 WRSR Operation

6. Read memory data (READ)

The READ operation is shown below. Input the instruction code and the address from serial data input (SI) after inputting “L” to the chip select (\overline{CS}). The input address is loaded to the internal address counter, and data in the address is output from the serial data output (SO).

Next, by inputting the serial clock (SCK) keeping the chip select (\overline{CS}) in “L”, the address is automatically incremented so that data in the following address is sequentially output. The address counter rolls over to the first address by increment in the last address.

To finish the Read cycle, set \overline{CS} to “H”. It is possible to raise the chip select always during the cycle. During Write, the READ instruction code is not be accepted or operated.

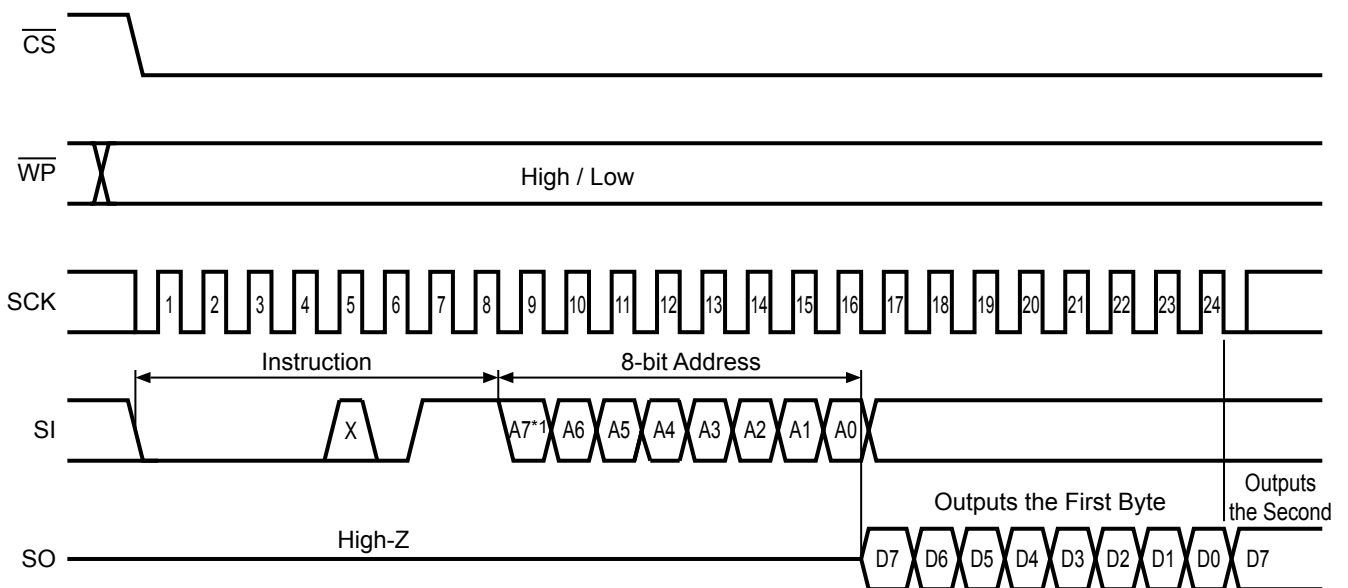

*1 In the S-25C010A, A7 = Don't care because the address range is A6 to A0.

Remark X = Don't care.

Figure 16 READ Operation (S-25C010A/020A)

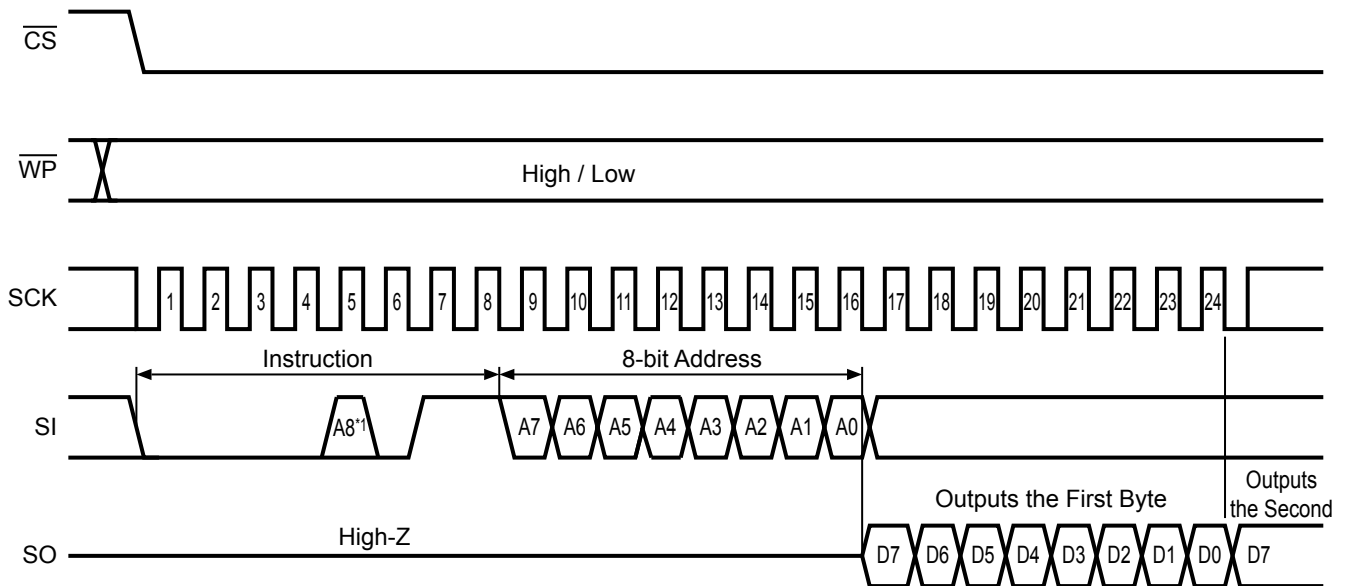

*1 In the S-25C040A, assign bit A8 in the address into the fifth bit in an instruction code.

Figure 17 READ Operation (S-25C040A)

7. Write memory data (WRITE)

Figures 18 and 19 show the timing charts when inputting 1-byte data. Input the instruction code, the address and data from serial data input (SI) after inputting “L” to the chip select (\overline{CS}). To start WRITE (t_{PR}), set the chip select (\overline{CS}) to “H” after inputting data or before inputting a rising of the next serial clock. Bit WIP and WEL are reset to “0” when Write has completed.

The S-25C010A/020A/040A can Page Write of 16 bytes. Its function to transmit data is as same as Byte Write basically, but it operates Page Write by receiving sequential 8-bit Write data as much data as page size has. Input the instruction code, the address and data from serial data input (SI) after inputting “L” in \overline{CS} , as the WRITE operation (page) shown in **Figures 20 and 21**. Input the next data while keeping \overline{CS} in “L”. After that, repeat inputting data of 8-bit sequentially. At the end, by setting \overline{CS} to “H”, the WRITE operation starts (t_{PR}).

4 of the lower bits in the address are automatically incremented every time when receiving Write data of 8-bit. Thus, even if Write data exceeds 16 bytes, the higher bits in the address do not change. And lower 4 bits in the address roll over so that Write data which is previously input is overwritten.

These are cases when the WRITE instruction is not accepted or operated.

- Bit WEL is not set to “1” (not set to “1” beforehand immediately before the WRITE instruction)
- During Write
- The address to be written is in the protect area by BP1 and BP0.
- The \overline{WP} signal is in “L”.

To cancel the WRITE instruction, input the clock different from a specified value ($n = 16 + m \times 8$ clocks) while \overline{CS} is in “L”.

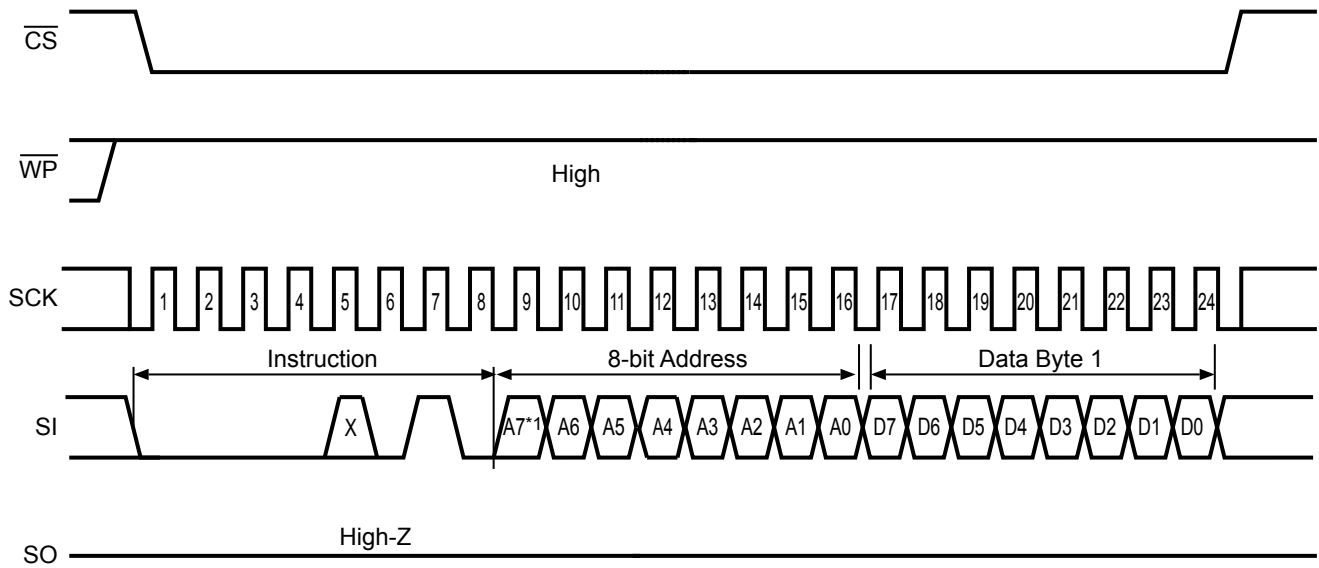

*1 In the S-25C010A, A7 = Don't care because the address range is A6 to A0.

Remark X = Don't care.

Figure 18 WRITE Operation (1 byte) (S-25C010A/020A)

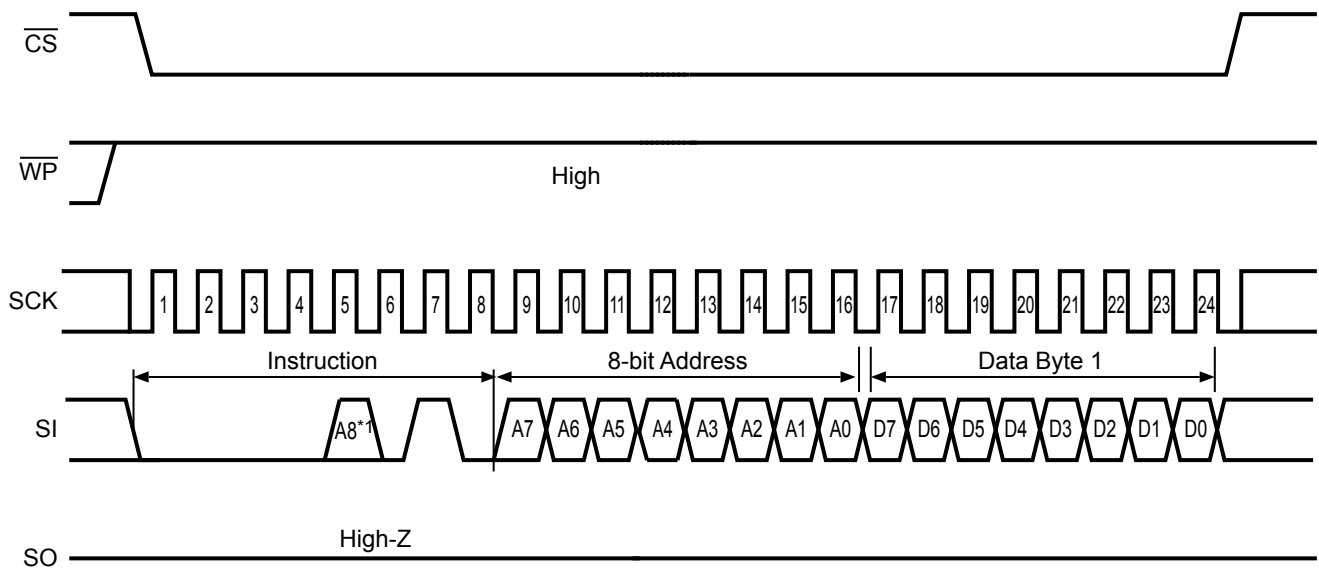

*1 In the S-25C040A, assign bit A8 in the address into the fifth bit in an instruction code.

Figure 19 WRITE Operation (1 byte) (S-25C040A)

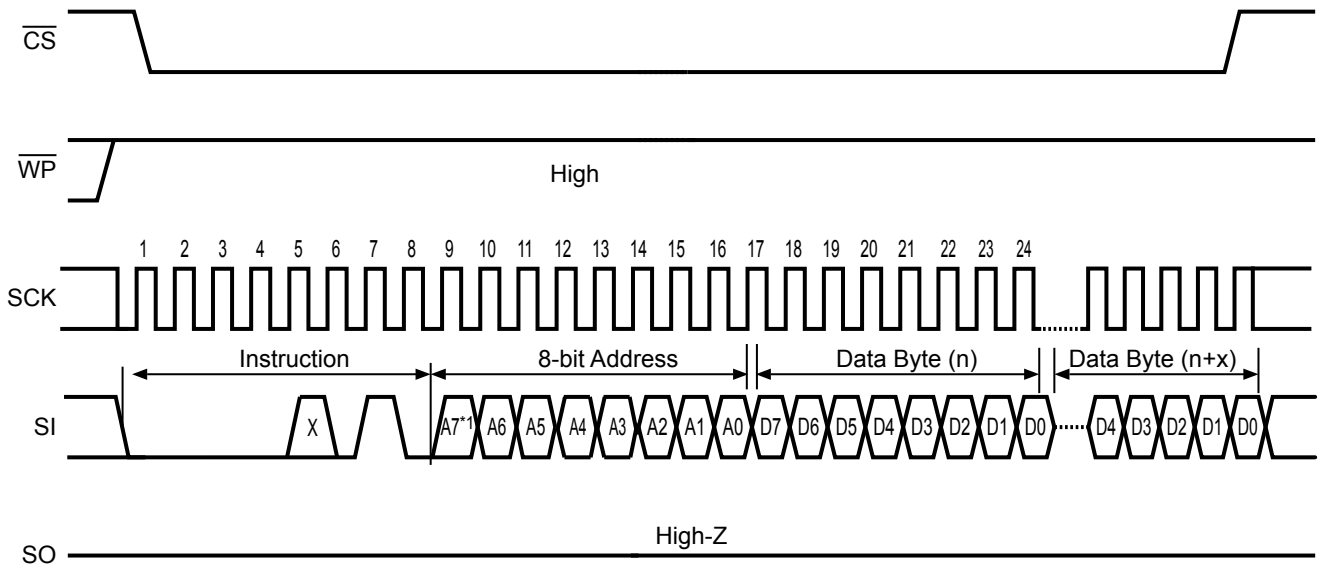

*1 In the S-25C010A, A7 = Don't care because the address range is A6 to A0.

Remark X = Don't care.

Figure 20 WRITE Operation (Page) (S-25C010A/020A)

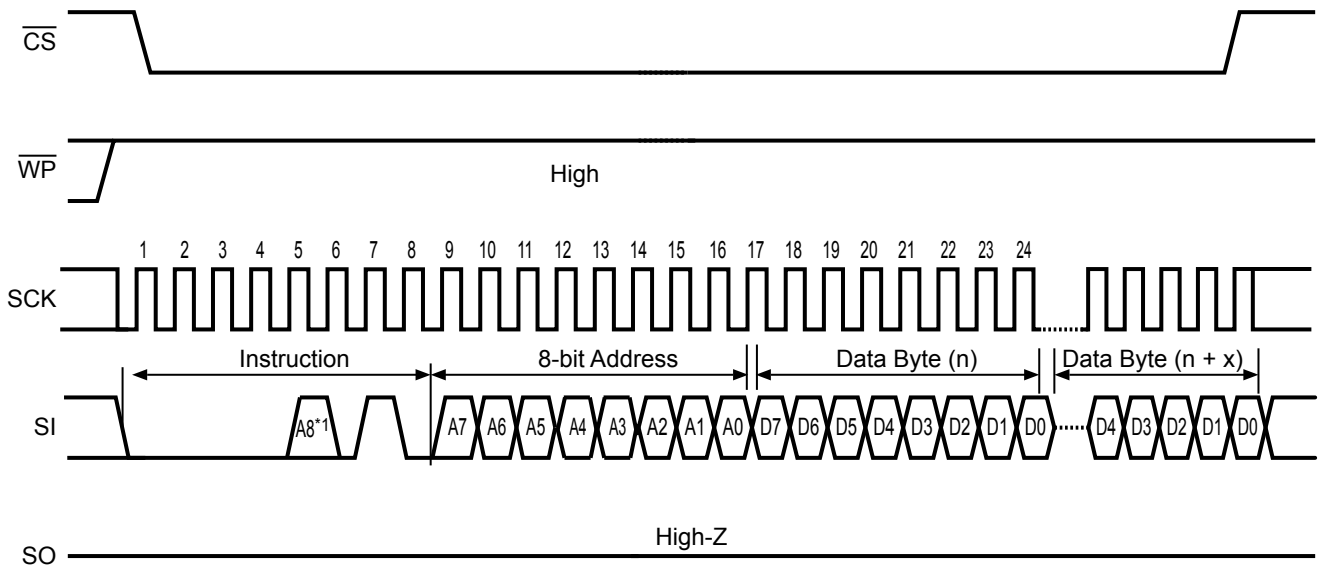

*1 In the S-25C040A, assign bit A8 in the address into the fifth bit in an instruction code.

Figure 21 WRITE Operation (Page) (S-25C040A)

■ Protect Operation

Table 17 shows the block settings of Write protect. Setting value in Protect Bits (BP1, BP0) in the status register protect data in the area of all/50%/25% of the memory address.

Setting signal \overline{WP} to “L” provides the following settings.

- Write protect for the WRITE, WRSR instructions
- Reset bit WEL

Figures 8 and 9 show the Valid timing in Write protect and Invalid timing in Write protect.

Table 17 Block Settings of Write Protect

Status Register		Area of Write Protect	Address of Write protect block		
BP1	BP0		S-25C040A	S-25C020A	S-25C010A
0	0	0%	None	None	None
0	1	25%	180h to 1FFh	C0h to FFh	60h to 7Fh
1	0	50%	100h to 1FFh	80h to FFh	40h to 7Fh
1	1	100%	000h to 1FFh	00h to FFh	00h to 7Fh

■ Hold Operation

The hold operation is used to pause serial communications without setting the device in the non-select status. In the hold status, the serial data output goes in high impedance, and both of the serial data input and the serial clock go in “Don’t care”. Be sure to set the chip select (\overline{CS}) to “L” to set the device in the select status during the hold status.

Generally, during the hold status, the device holds the select status. But if setting the device in the non-select status, the users can finish the operation even in progress.

Figure 22 shows the hold operation. Set Hold (\overline{HOLD}) to “L” when the serial clock (SCK) is in “L”, Hold (\overline{HOLD}) is switched at the same time the hold status starts. If setting Hold (\overline{HOLD}) to “H”, Hold (\overline{HOLD}) is switched at the same time the hold status ends.

Set Hold (\overline{HOLD}) to “L” when the serial clock (SCK) is in “H”; the hold status starts when the serial clock goes in “L” after Hold (\overline{HOLD}) is switched. If setting Hold (\overline{HOLD}) to “H”, the hold status ends when the serial clock goes in “L” after Hold (\overline{HOLD}) is switched.

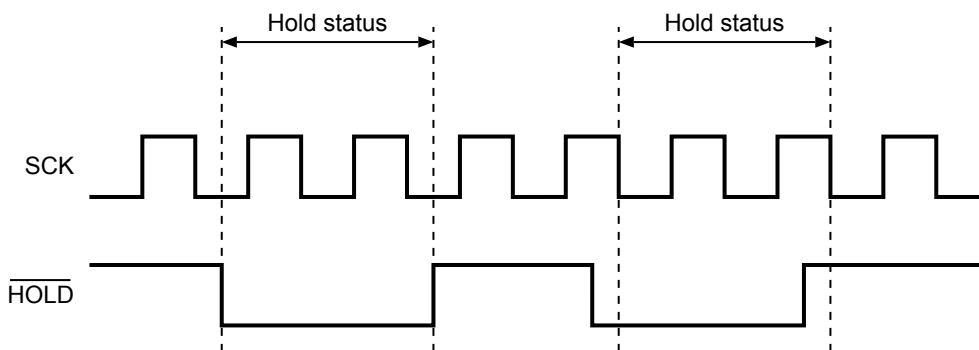

Figure 22 Hold Operation

■ Write Protect Function during the Low Power Supply Voltage

The S-25C010A/020A/040A has a built-in detection circuit which operates with the low power supply voltage. The S-25C010A/020A/040A cancels the Write operation (WRITE, WRSR) when the power supply voltage drops and power-on, at the same time, goes in the Write protect status (WRDI) automatically to reset bit WEL. The detection voltage is 1.20 V typ., the release voltage is 1.35 V typ., and its hysteresis is approx. 0.15 V (Refer to **Figure 23**).

To operate Write, after the power supply voltage dropped once but rose to the voltage level which allows Write again, be sure to set the Write Enable Latch bit (WEL) before operating Write (WRITE, WRSR).

In the Write operation, data in the address written during the low power supply voltage is not assured.

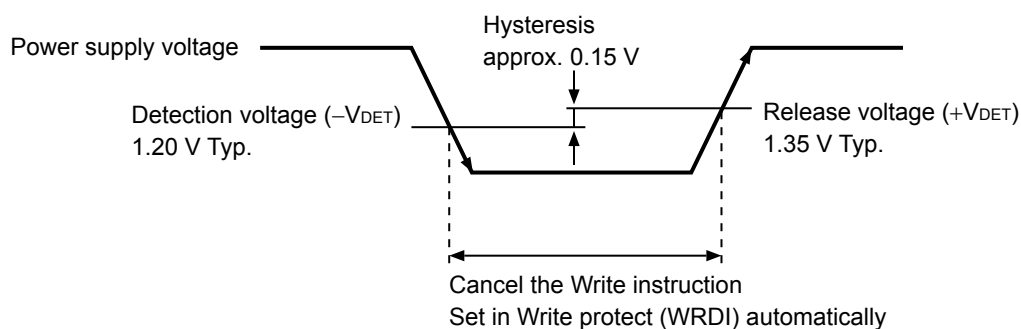

Figure 23 Operation during Low Power Supply Voltage

■ I/O Pin

1. Connection of input pin

All input pins in S-25C010A/020A/040A have the CMOS structure. Do not set these pins in high impedance during operation when you design. Especially, set the \overline{CS} input in the non-select status "H" during power-on/off and standby. The error Write does not occur as long as the \overline{CS} pin is in the non-select status "H". Set the \overline{CS} pin to V_{CC} via a resistor (the pull-up resistor of 10 kΩ to 100 kΩ).

If the \overline{CS} pin and the SCK pin change from "L" to "H" simultaneously, data may be input from the SI pin.

To prevent the error for sure, it is recommended to pull down the SCK pin to GND. In addition, it is recommended to pull up the SI pin, the \overline{WP} pin and the \overline{HOLD} pin to V_{CC}, or pull down these pins to GND, respectively. Connecting the \overline{WP} pin and the \overline{HOLD} pin to V_{CC} directly is also possible when these pins are not in use.

2. Equivalent circuit of input and output pin

Figures 24 and 25 show the equivalent circuits of input pins in S-25C010A/020A/040A. A pull-up and pull-down elements are not included in each input pin, pay attention not to set it in the floating state when you design.

Figure 26 shows the equivalent circuit of the output pin. This pin has the tri-state output of "H" level/"L" level/high impedance.

2.1 Input pin

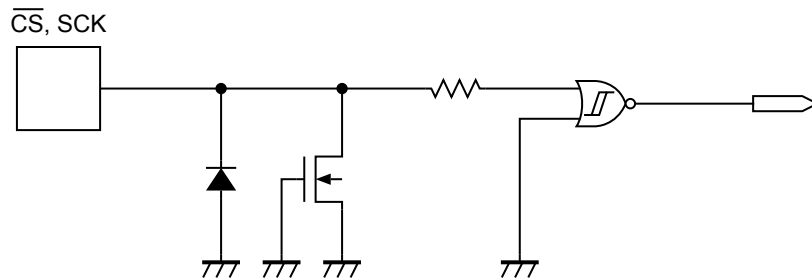

Figure 24 \overline{CS} , SCK Pins

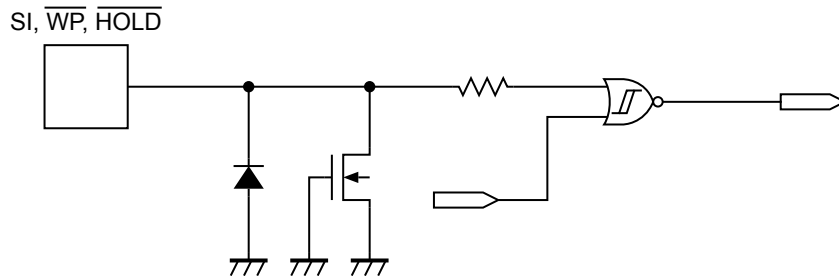

Figure 25 SI, \overline{WP} , \overline{HOLD} Pins

2.2 Output pin

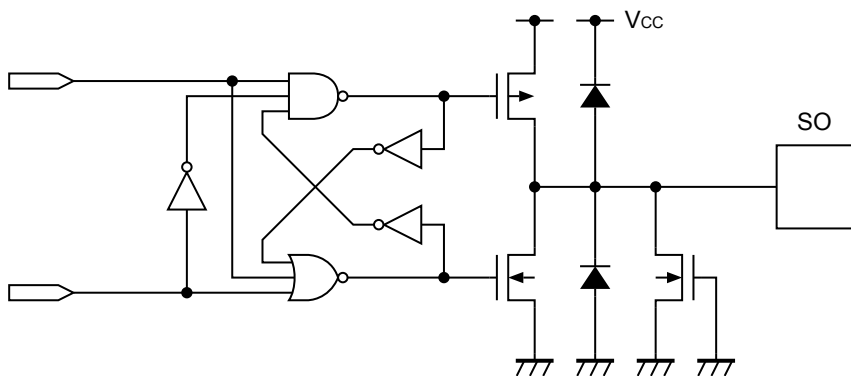

Figure 26 SO Pin

3. Precaution for use

- Absolute maximum ratings: Do not operate these ICs in excess of the absolute maximum ratings (as listed on the data sheet). Exceeding the supply voltage rating can cause latch-up. Perform operations after confirming the detailed operation condition in the data sheet.
- Operations with moisture on the S-25C010A/020A/040A pins may occur malfunction by short-circuit between pins. Especially, in occasions like picking the S-25C010A/020A/040A up from low temperature tank during the evaluation. Be sure that not remain frost on the S-25C010A/020A/040A's pins to prevent malfunction by short-circuit. Also attention should be paid in using on environment, which is easy to dew for the same reason.

■ **Precaution**

- Do not apply an electrostatic discharge to this IC that exceeds the performance ratings of the built-in electrostatic protection circuit.
- ABLIC Inc. claims no responsibility for any and all disputes arising out of or in connection with any infringement of the products including this IC upon patents owned by a third party.

■ **Product Name Structure**

1. **Product name**

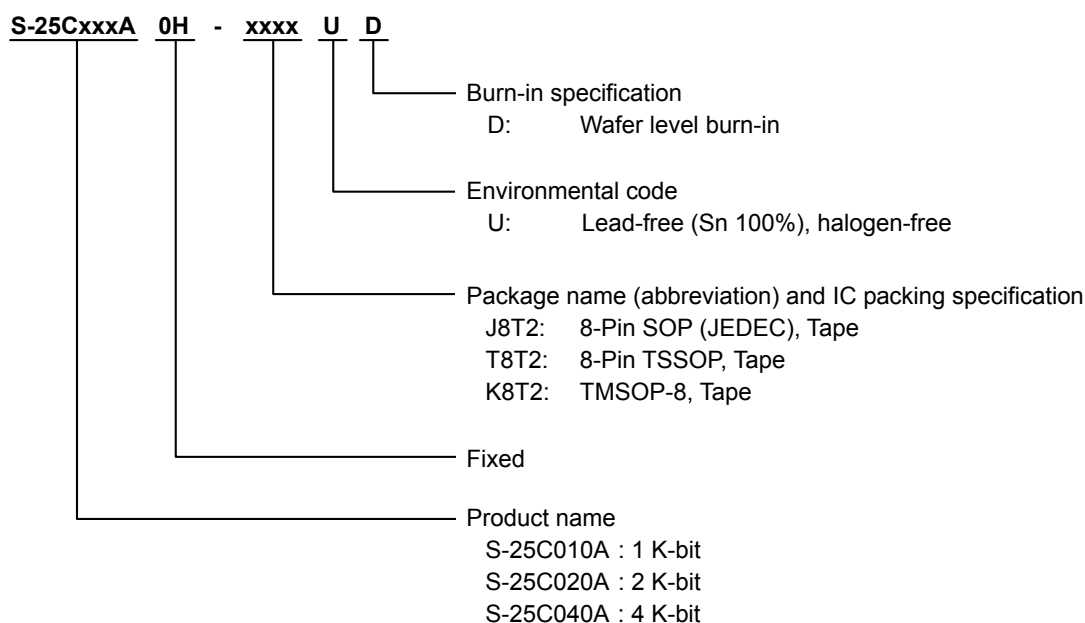

Remark Please contact our sales office for products with product name structure other than those specified above.

2. **Package**

Package Name	Drawing Code		
	Package	Tape	Reel
8-Pin SOP (JEDEC)	FJ008-A-P-SD	FJ008-D-C-SD	FJ008-D-R-S1
8-Pin TSSOP	FT008-A-P-SD	FT008-E-C-SD	FT008-E-R-S1
TMSOP-8	FM008-A-P-SD	FM008-A-C-SD	FM008-A-R-SD

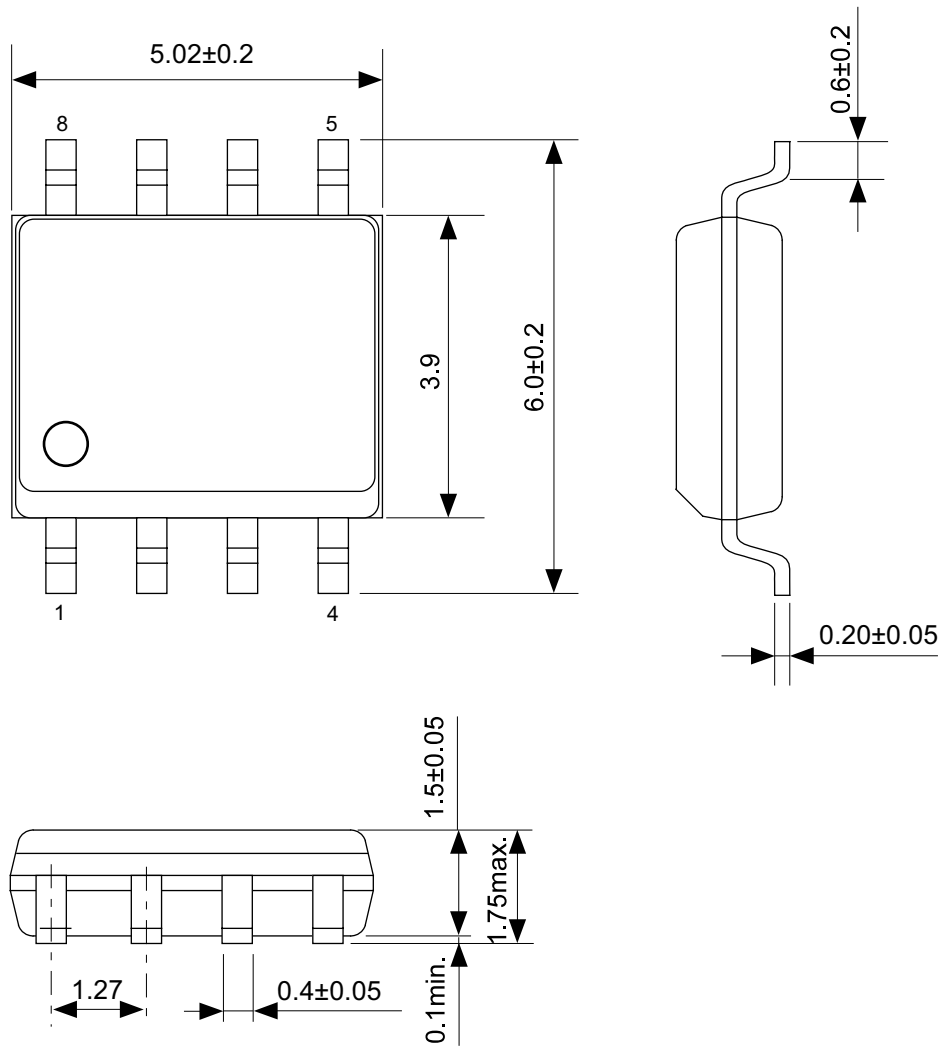

No. FJ008-A-P-SD-2.2

TITLE	SOP8J-D-PKG Dimensions
No.	FJ008-A-P-SD-2.2
ANGLE	
UNIT	mm
ABLIC Inc.	

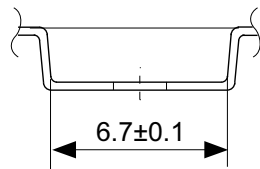
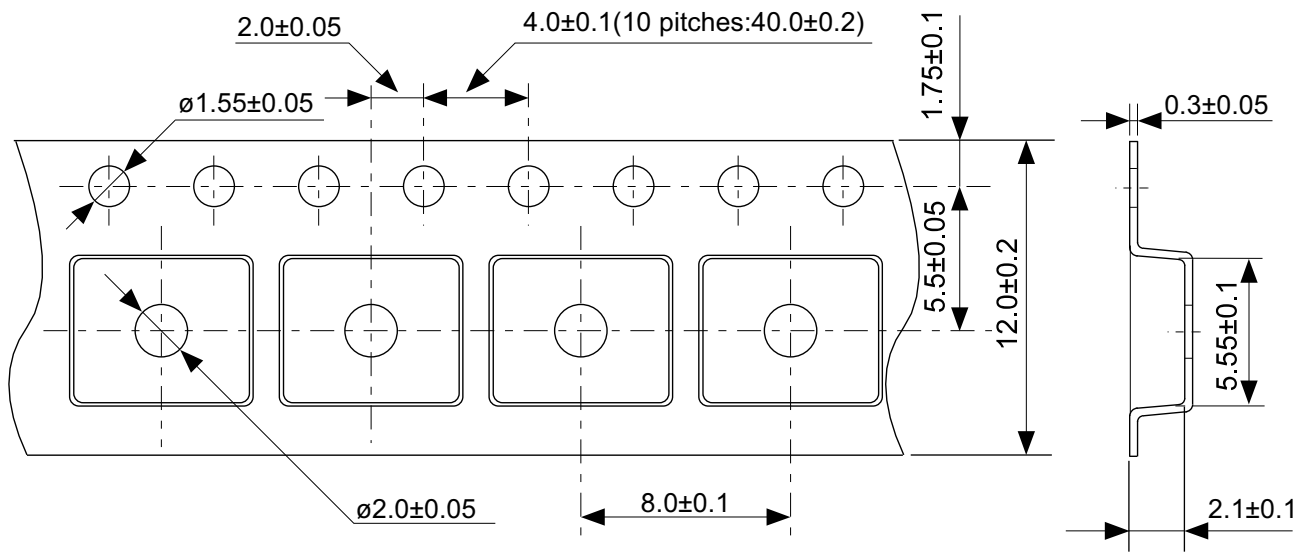

→
Feed direction

No. FJ008-D-C-SD-1.1

TITLE	SOP8J-D-Carrier Tape
No.	FJ008-D-C-SD-1.1
ANGLE	
UNIT	mm
ABLIC Inc.	

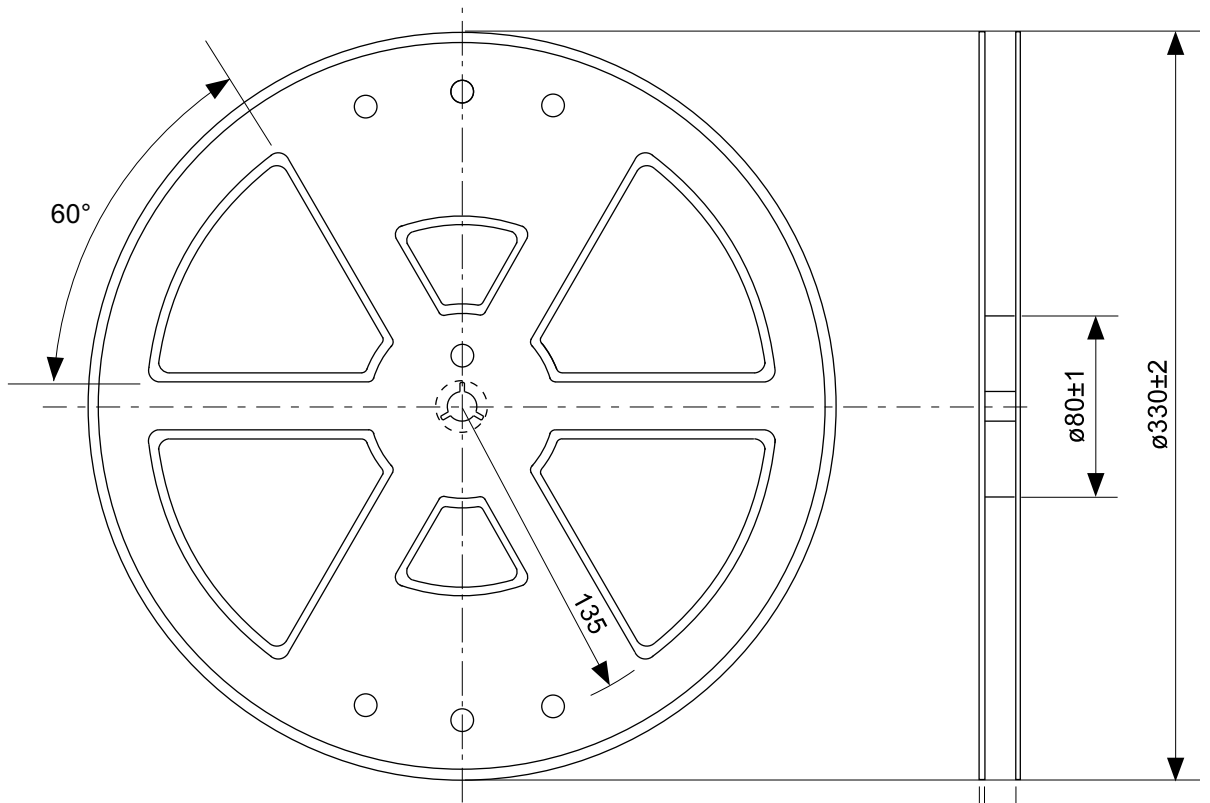

Enlarged drawing in the central part

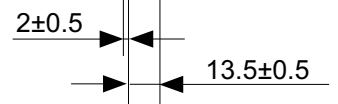
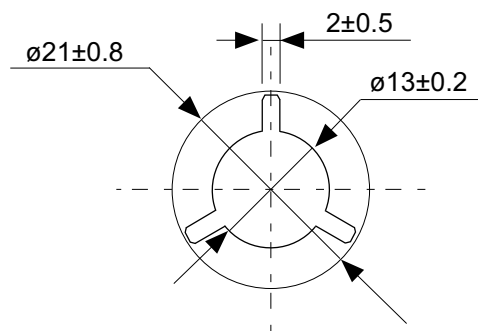

No. FJ008-D-R-S1-1.0

TITLE	SOP8J-D-Reel		
No.	FJ008-D-R-S1-1.0		
ANGLE		QTY.	4,000
UNIT	mm		
ABLIC Inc.			

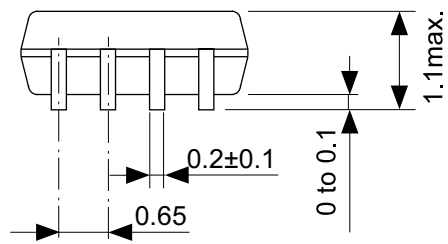
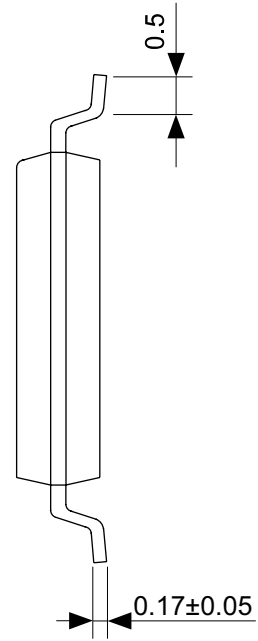

No. FT008-A-P-SD-1.2

TITLE	TSSOP8-E-PKG Dimensions
No.	FT008-A-P-SD-1.2
ANGLE	
UNIT	mm
ABLIC Inc.	

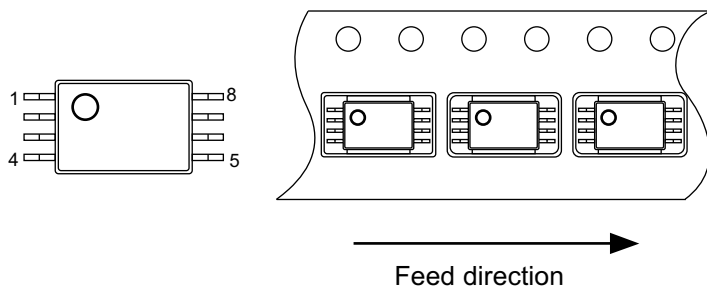
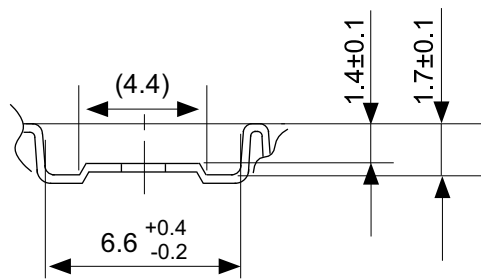

No. FT008-E-C-SD-1.0

TITLE	TSSOP8-E-Carrier Tape
No.	FT008-E-C-SD-1.0
ANGLE	
UNIT	mm
ABLIC Inc.	



Enlarged drawing in the central part



No. FT008-E-R-S1-1.0

TITLE	TSSOP8-E-Reel		
No.	FT008-E-R-S1-1.0		
ANGLE		QTY.	4,000
UNIT	mm		
ABLIC Inc.			



No. FM008-A-P-SD-1.2

TITLE	TMSOP8-A-PKG Dimensions
No.	FM008-A-P-SD-1.2
ANGLE	
UNIT	mm
ABLIC Inc.	



No. FM008-A-C-SD-2.0

TITLE	TMSOP8-A-Carrier Tape
No.	FM008-A-C-SD-2.0
ANGLE	
UNIT	mm
ABLIC Inc.	



Enlarged drawing in the central part

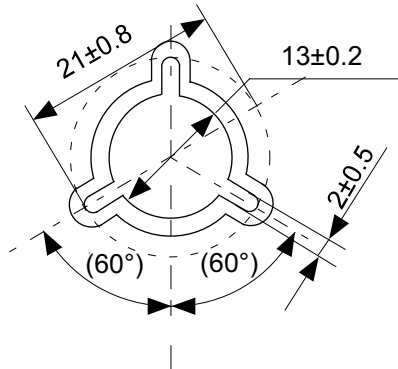

No. FM008-A-R-SD-1.0

TITLE	TMSOP8-A-Reel		
No.	FM008-A-R-SD-1.0		
ANGLE		QTY.	4,000
UNIT	mm		
ABLIC Inc.			

Disclaimers (Handling Precautions)

1. All the information described herein (product data, specifications, figures, tables, programs, algorithms and application circuit examples, etc.) is current as of publishing date of this document and is subject to change without notice.
2. The circuit examples and the usages described herein are for reference only, and do not guarantee the success of any specific mass-production design.
ABLIC Inc. is not liable for any losses, damages, claims or demands caused by the reasons other than the products described herein (hereinafter "the products") or infringement of third-party intellectual property right and any other right due to the use of the information described herein.
3. ABLIC Inc. is not liable for any losses, damages, claims or demands caused by the incorrect information described herein.
4. Be careful to use the products within their ranges described herein. Pay special attention for use to the absolute maximum ratings, operation voltage range and electrical characteristics, etc.
ABLIC Inc. is not liable for any losses, damages, claims or demands caused by failures and / or accidents, etc. due to the use of the products outside their specified ranges.
5. Before using the products, confirm their applications, and the laws and regulations of the region or country where they are used and verify suitability, safety and other factors for the intended use.
6. When exporting the products, comply with the Foreign Exchange and Foreign Trade Act and all other export-related laws, and follow the required procedures.
7. The products are strictly prohibited from using, providing or exporting for the purposes of the development of weapons of mass destruction or military use. ABLIC Inc. is not liable for any losses, damages, claims or demands caused by any provision or export to the person or entity who intends to develop, manufacture, use or store nuclear, biological or chemical weapons or missiles, or use any other military purposes.
8. The products are not designed to be used as part of any device or equipment that may affect the human body, human life, or assets (such as medical equipment, disaster prevention systems, security systems, combustion control systems, infrastructure control systems, vehicle equipment, traffic systems, in-vehicle equipment, aviation equipment, aerospace equipment, and nuclear-related equipment), excluding when specified for in-vehicle use or other uses by ABLIC, Inc. Do not apply the products to the above listed devices and equipments.
ABLIC Inc. is not liable for any losses, damages, claims or demands caused by unauthorized or unspecified use of the products.
9. In general, semiconductor products may fail or malfunction with some probability. The user of the products should therefore take responsibility to give thorough consideration to safety design including redundancy, fire spread prevention measures, and malfunction prevention to prevent accidents causing injury or death, fires and social damage, etc. that may ensue from the products' failure or malfunction.
The entire system in which the products are used must be sufficiently evaluated and judged whether the products are allowed to apply for the system on customer's own responsibility.
10. The products are not designed to be radiation-proof. The necessary radiation measures should be taken in the product design by the customer depending on the intended use.
11. The products do not affect human health under normal use. However, they contain chemical substances and heavy metals and should therefore not be put in the mouth. The fracture surfaces of wafers and chips may be sharp. Be careful when handling these with the bare hands to prevent injuries, etc.
12. When disposing of the products, comply with the laws and ordinances of the country or region where they are used.
13. The information described herein contains copyright information and know-how of ABLIC Inc. The information described herein does not convey any license under any intellectual property rights or any other rights belonging to ABLIC Inc. or a third party. Reproduction or copying of the information from this document or any part of this document described herein for the purpose of disclosing it to a third-party is strictly prohibited without the express permission of ABLIC Inc.
14. For more details on the information described herein or any other questions, please contact ABLIC Inc.'s sales representative.
15. This Disclaimers have been delivered in a text using the Japanese language, which text, despite any translations into the English language and the Chinese language, shall be controlling.

2.4-2019.07