

The S-82G1A Series is a protection IC for lithium-ion / lithium polymer rechargeable batteries, which includes high-accuracy voltage detection circuits and delay circuits. It is suitable for protecting 1-cell lithium-ion / lithium polymer rechargeable battery packs from overcharge, overdischarge, and overcurrent.

Using the S-82G1A Series makes it possible to configure a protection circuit which separates the charge and discharge current paths.

Independent charge current path suppresses heat generation during charging.

The S-82G1A Series also has an input pin for charge-discharge control signal, allowing for charge-discharge control with an external signal.

■ Features

- High-accuracy voltage detection circuit

Overcharge detection voltage	3.500 V to 4.600 V (5 mV step)	Accuracy ±15 mV
Overcharge release voltage	3.100 V to 4.600 V ^{*1}	Accuracy ±50 mV
Overdischarge detection voltage	2.000 V to 3.000 V (10 mV step)	Accuracy ±50 mV
Overdischarge release voltage	2.000 V to 3.400 V ^{*2}	Accuracy ±75 mV
Discharge overcurrent detection voltage 1	0.003 V to 0.100 V (0.5 mV step)	Accuracy ±1.5 mV
Discharge overcurrent detection voltage 2	0.010 V to 0.100 V (1 mV step)	Accuracy ±3 mV
Load short-circuiting detection voltage	0.020 V to 0.100 V (1 mV step)	Accuracy ±5 mV
Charge overcurrent detection voltage	-0.100 V to -0.010 V (1 mV step)	Accuracy ±3 mV
- Detection delay times are generated only by an internal circuit (external capacitors are unnecessary).
- Charge-discharge control function

CTL pin control logic is selectable:	Active "H", active "L"
CTL pin internal resistance connection is selectable:	Pull-up, pull-down
CTL pin internal resistance value is selectable:	1 MΩ to 10 MΩ (1 MΩ step)
Charge-discharge inhibition status release function by VMD pin is selectable:	Available, unavailable
Transition from charge-discharge inhibition status to discharge overcurrent status is selectable:	Available, unavailable
- Discharge overcurrent control function

Load short-circuiting detection 2 function is selectable:	Available, unavailable
Release condition of discharge overcurrent status:	Load disconnection
Release voltage of discharge overcurrent status:	$V_{RIOV} = V_{DD} \times 0.8$
- 0 V battery charge function is selectable: Available, unavailable
- Power-down function is selectable: Available, unavailable
- High-withstand voltage: VMC pin, VMD pin and CO pin: Absolute maximum rating 28 V
- Wide operation temperature range: Ta = -40°C to +85°C
- Low current consumption

During operation:	2.0 μA typ., 4.0 μA max. (Ta = +25°C)
During power-down:	50 nA max. (Ta = +25°C)
During overdischarge:	0.5 μA max. (Ta = +25°C)
- Lead-free (Sn 100%), halogen-free

*1. Overcharge release voltage = Overcharge detection voltage – Overcharge hysteresis voltage
(Overcharge hysteresis voltage can be selected as 0 V or from a range of 0.1 V to 0.4 V in 50 mV step.)

*2. Overdischarge release voltage = Overdischarge detection voltage + Overdischarge hysteresis voltage
(Overdischarge hysteresis voltage can be selected as 0 V or from a range of 0.1 V to 0.7 V in 100 mV step.)

■ Applications

- Lithium-ion rechargeable battery pack
- Lithium polymer rechargeable battery pack

■ Package

- HSNT-8(1616)

■ **Block Diagram**

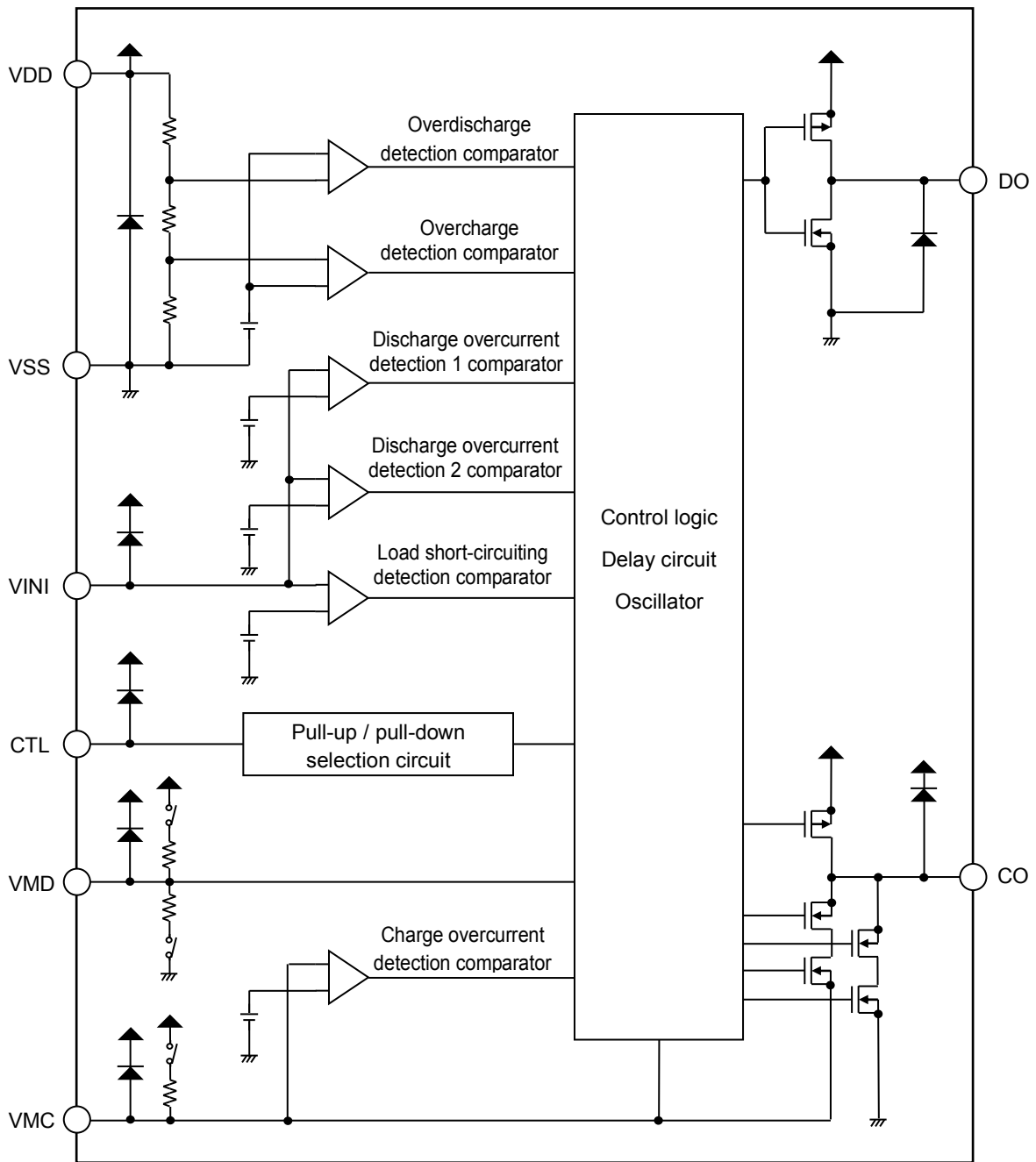
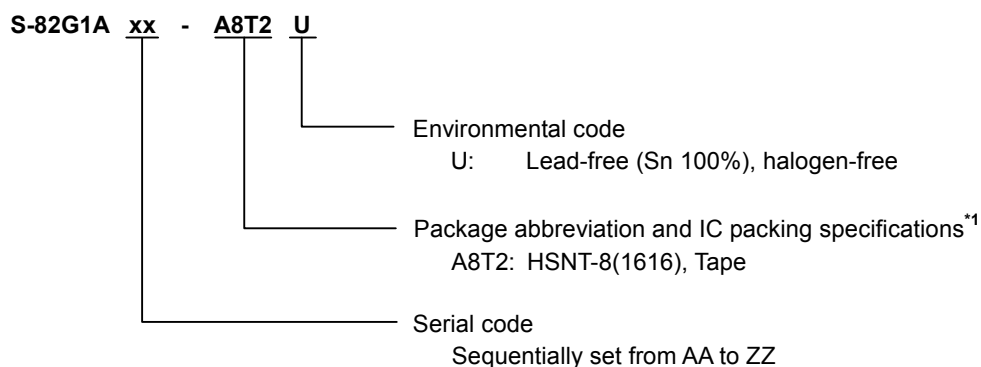

Figure 1

■ Product Name Structure

1. Product name



*1. Refer to the tape drawing.

2. Package

Table 1 Package Drawing Codes

Package Name	Dimension	Tape	Reel	Land
HSNT-8(1616)	PY008-A-P-SD	PY008-A-C-SD	PY008-A-R-SD	PY008-A-L-SD

3. Product name list

Table 2 (1 / 2)

Product Name	Overcharge Detection Voltage [V _{CU}]	Overcharge Release Voltage [V _{CL}]	Overdischarge Detection Voltage [V _{DL}]	Overdischarge Release Voltage [V _{DU}]	Delay Time Combination* ¹	CTL Pin Combination* ²	Function Combination* ³
S-82G1AAA-A8T2U	4.445 V	4.295 V	2.350 V	2.550 V	(1)	(1)	(1)

Table 2 (2 / 2)

Product Name	Discharge Overcurrent Detection Voltage 1 [V _{DIOV1}]	Discharge Overcurrent Detection Voltage 2 [V _{DIOV2}]	Load Short-circuiting Detection Voltage [V _{SHORT}]	Charge Overcurrent Detection Voltage [V _{CI0V}]
S-82G1AAA-A8T2U	0.014 V	0.020 V	0.052 V	-0.057 V

*1. Refer to **Table 3** about the details of the delay time combinations.

*2. Refer to **Table 5** about the details of CTL pin combinations.

*3. Refer to **Table 6** about the details of function combinations.

Remark Please contact our sales office for products other than the above.

Table 3

Delay Time Combination	Overcharge Detection Delay Time [t _{CU}]	Overdischarge Detection Delay Time [t _{DL}]	Discharge Overcurrent Detection Delay Time 1 [t _{DIOV1}]	Discharge Overcurrent Detection Delay Time 2 [t _{DIOV2}]	Load Short-circuiting Detection Delay Time [t _{SHORT}]	Charge Overcurrent Detection Delay Time [t _{CIOV}]	Charge-discharge Inhibition Delay Time [t _{CTL}]
(1)	1.0 s	64 ms	3.75 s	16 ms	280 μs	16 ms	48 ms

Remark The delay times can be changed within the range listed in **Table 4**. For details, please contact our sales office.

Table 4

Delay Time	Symbol	Selection Range						Remark
Overcharge detection delay time	t _{CU}	256 ms	512 ms	1.0 s	–	–	–	Select a value from the left.
Overdischarge detection delay time	t _{DL}	32 ms	64 ms	128 ms	–	–	–	Select a value from the left.
Discharge overcurrent detection delay time 1	t _{DIOV1}	8 ms	16 ms	32 ms	64 ms	128 ms	256 ms	Select a value from the left.
		512 ms	1.0 s	2.0 s	3.0 s	3.75 s	4.0 s	
Discharge overcurrent detection delay time 2	t _{DIOV2}	4 ms	8 ms	16 ms	32 ms	64 ms	128 ms	Select a value from the left.
Load short-circuiting detection delay time	t _{SHORT}	280 μs	530 μs	–	–	–	–	Select a value from the left.
Charge overcurrent detection delay time	t _{CIOV}	4 ms	8 ms	16 ms	32 ms	64 ms	128 ms	Select a value from the left.
Charge-discharge inhibition delay time	t _{CTL}	2 ms	4 ms	48 ms	64 ms	128 ms	256 ms	Select a value from the left.

Table 5

CTL Pin Combination	Control Logic*1	Internal Resistance Connection*2	Internal Resistance Value*3 [R _{CTL}]	Pin Voltage "H"*4 [V _{CTLH}]	Pin Voltage "L"*5 [V _{CTLL}]
(1)	Active "H"	Pull-down	5 MΩ	V _{SS} + 0.65 V	V _{SS} + 0.60 V

- *1. CTL pin control logic active "H" / active "L" is selectable.
- *2. CTL pin internal resistance connection "pull-up" / "pull-down" is selectable.
- *3. CTL pin internal resistance value is selectable from 1 MΩ to 10 MΩ (1 MΩ step).
- *4. CTL pin voltage "H" is selectable from "V_{SS} + 0.65 V" / "V_{DD} - 0.9 V".
- *5. CTL pin voltage "L" is selectable from "V_{SS} + 0.60 V" / "V_{DD} - 0.9 V".

Remark Please contact our sales office for products other than the above.

Table 6

Function Combination	Charge-discharge Inhibition Status Release Function by VMD Pin*1	Transition from Charge-discharge Inhibition Status to Discharge Overcurrent Status*2	Load Short-circuiting Detection 2 Function*3	0 V Battery Charge Function*4	Power-down Function*5
(1)	Available	Unavailable	Available	Available	Unavailable

- *1. Charge-discharge inhibition status release function by VMD pin "available" / "unavailable" is selectable.
- *2. Transition from charge-discharge inhibition status to discharge overcurrent status "available" / "unavailable" is selectable.
- *3. Load short-circuiting detection 2 function "available" / "unavailable" is selectable.
- *4. 0 V battery charge function "available" / "unavailable" is selectable.
- *5. Power-down function "available" / "unavailable" is selectable.

Remark Please contact our sales office for products other than the above.

■ Pin Configuration

1. HSNT-8(1616)

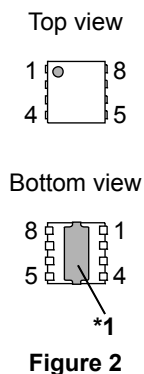

Table 7

Pin No.	Symbol	Description
1	VMD	Load monitoring pin
2	VMC	Negative power supply pin for charge control
3	CO	Connection pin of charge control FET gate (CMOS output)
4	DO	Connection pin of discharge control FET gate (CMOS output)
5	VSS	Input pin for negative power supply
6	VDD	Input pin for positive power supply
7	VINI	Discharge overcurrent detection pin
8	CTL	Input pin for charge-discharge control signal

*1. Connect the heat sink of backside at shadowed area to the board, and set electric potential open or V_{DD} . However, do not use it as the function of electrode.

■ **Absolute Maximum Ratings**

Table 8

(Ta = +25°C unless otherwise specified)

Item	Symbol	Applied Pin	Absolute Maximum Rating	Unit
Input voltage between VDD pin and VSS pin	V _{DS}	VDD	V _{SS} - 0.3 to V _{SS} + 6	V
VINI pin input voltage	V _{VINI}	VINI	V _{DD} - 6 to V _{DD} + 0.3	V
CTL pin input voltage	V _{CTL}	CTL	V _{DD} - 6 to V _{DD} + 0.3	V
VMC pin input voltage	V _{VMC}	VMC	V _{DD} - 28 to V _{DD} + 0.3	V
VMD pin input voltage	V _{VMD}	VMD	V _{DD} - 28 to V _{DD} + 0.3	V
DO pin output voltage	V _{DO}	DO	V _{SS} - 0.3 to V _{DD} + 0.3	V
CO pin output voltage	V _{CO}	CO	V _{DD} - 28 to V _{DD} + 0.3	V
Operation ambient temperature	T _{opr}	-	-40 to +85	°C
Storage temperature	T _{stg}	-	-55 to +125	°C

Caution The absolute maximum ratings are rated values exceeding which the product could suffer physical damage. These values must therefore not be exceeded under any conditions.

■ **Thermal Resistance Value**

Table 9

Item	Symbol	Condition	Min.	Typ.	Max.	Unit	
Junction-to-ambient thermal resistance*1	θ _{JA}	HSNT-8(1616)	Board A	-	214	-	°C/W
			Board B	-	172	-	°C/W
			Board C	-	-	-	°C/W
			Board D	-	-	-	°C/W
			Board E	-	-	-	°C/W

*1. Test environment: compliance with JEDEC STANDARD JESD51-2A

Remark Refer to "■ Power Dissipation" and "Test Board" for details.

■ Electrical Characteristics

1. Ta = +25°C

Table 10

(Ta = +25°C unless otherwise specified)

Item	Symbol	Condition	Min.	Typ.	Max.	Unit	Test Circuit
Detection Voltage							
Overcharge detection voltage	V _{CU}	–	V _{CU} – 0.015	V _{CU}	V _{CU} + 0.015	V	1
		Ta = –20°C to +60°C*1	V _{CU} – 0.020	V _{CU}	V _{CU} + 0.020	V	1
Overcharge release voltage	V _{CL}	V _{CL} ≠ V _{CU}	V _{CL} – 0.050	V _{CL}	V _{CL} + 0.050	V	1
		V _{CL} = V _{CU}	V _{CL} – 0.020	V _{CL}	V _{CL} + 0.015	V	1
Overdischarge detection voltage	V _{DL}	–	V _{DL} – 0.050	V _{DL}	V _{DL} + 0.050	V	2
Overdischarge release voltage	V _{DU}	V _{DL} ≠ V _{DU}	V _{DU} – 0.075	V _{DU}	V _{DU} + 0.075	V	2
		V _{DL} = V _{DU}	V _{DU} – 0.050	V _{DU}	V _{DU} + 0.050	V	2
Discharge overcurrent detection voltage 1	V _{DIOV1}	–	V _{DIOV1} – 0.0015	V _{DIOV1}	V _{DIOV1} + 0.0015	V	5
Discharge overcurrent detection voltage 2	V _{DIOV2}	–	V _{DIOV2} – 0.003	V _{DIOV2}	V _{DIOV2} + 0.003	V	2
Load short-circuiting detection voltage	V _{SHORT}	–	V _{SHORT} – 0.005	V _{SHORT}	V _{SHORT} + 0.005	V	2
Load short-circuiting detection voltage 2	V _{SHORT2}	–	V _{DD} – 1.2	V _{DD} – 0.8	V _{DD} – 0.5	V	2
Charge overcurrent detection voltage	V _{CIOV}	–	V _{CIOV} – 0.003	V _{CIOV}	V _{CIOV} + 0.003	V	2
Discharge overcurrent release voltage	V _{RIOV}	V _{DD} = 3.4 V	V _{DD} × 0.77	V _{DD} × 0.80	V _{DD} × 0.83	V	5
0 V Battery Charge Function							
0 V battery charge starting charger voltage	V _{0CHA}	0 V battery charge function "available"	0.7	1.3	1.7	V	4
0 V battery charge inhibition battery voltage	V _{0INH}	0 V battery charge function "unavailable"	0.9	1.2	1.5	V	2
Internal Resistance							
Resistance between VDD pin and VMC pin	R _{VMCD}	V _{DD} = 1.8 V, V _{VMC} = 0 V	500	1250	2500	kΩ	3
Resistance between VDD pin and VMD pin	R _{VMDD}	V _{DD} = 1.8 V, V _{VMD} = 0 V	500	1250	2500	kΩ	3
Resistance between VMD pin and VSS pin	R _{VMDS}	V _{DD} = 3.4 V, V _{VMD} = 1.0 V	5	10	15	kΩ	3
CTL pin internal resistance	R _{CTL}	–	R _{CTL} × 0.5	R _{CTL}	R _{CTL} × 2.0	MΩ	3
Input Voltage							
Operation voltage between VDD pin and VSS pin	V _{DSOP1}	–	1.5	–	6.0	V	–
Operation voltage between VDD pin and VMC pin, VMD pin	V _{DSOP2}	–	1.5	–	28	V	–
CTL pin voltage "H"	V _{CTLH}	–	V _{CTLH} – 0.3	V _{CTLH}	V _{CTLH} + 0.3	V	2
CTL pin voltage "L"	V _{CTLL}	–	V _{CTLL} – 0.3	V _{CTLL}	V _{CTLL} + 0.3	V	2
Input Current							
Current consumption during operation	I _{OPE}	V _{DD} = 3.4 V, V _{VMC} = V _{VMD} = 0 V	–	2.0	4.0	μA	3
Current consumption during power-down	I _{PDN}	V _{DD} = V _{VMC} = V _{VMD} = 1.5 V	–	–	0.05	μA	3
Current consumption during overdischarge	I _{OPED}	V _{DD} = V _{VMC} = V _{VMD} = 1.5 V	–	–	0.5	μA	3
Output Resistance							
CO pin resistance "H"	R _{COH}	–	5	10	20	kΩ	4
CO pin resistance "L"	R _{COL}	–	5	10	20	kΩ	4
DO pin resistance "H"	R _{DOH}	–	5	10	20	kΩ	4
DO pin resistance "L"	R _{DOL}	–	1	2	4	kΩ	4
Delay Time							
Overcharge detection delay time	t _{CU}	–	t _{CU} × 0.7	t _{CU}	t _{CU} × 1.3	–	5
Overdischarge detection delay time	t _{DL}	–	t _{DL} × 0.7	t _{DL}	t _{DL} × 1.3	–	5
Discharge overcurrent detection delay time 1	t _{DIOV1}	–	t _{DIOV1} × 0.75	t _{DIOV1}	t _{DIOV1} × 1.25	–	5
		Ta = –20°C to +60°C*1	t _{DIOV1} × 0.65	t _{DIOV1}	t _{DIOV1} × 1.35	–	5
Discharge overcurrent detection delay time 2	t _{DIOV2}	–	t _{DIOV2} × 0.7	t _{DIOV2}	t _{DIOV2} × 1.3	–	5
Load short-circuiting detection delay time	t _{SHORT}	–	t _{SHORT} × 0.7	t _{SHORT}	t _{SHORT} × 1.3	–	5
Charge overcurrent detection delay time	t _{CIOV}	–	t _{CIOV} × 0.7	t _{CIOV}	t _{CIOV} × 1.3	–	5
Charge-discharge inhibition delay time	t _{CTL}	–	t _{CTL} × 0.7	t _{CTL}	t _{CTL} × 1.3	–	5

*1. Since products are not screened at high and low temperature, the specification for this temperature range is guaranteed by design, not tested in production.

CHARGE-DISCHARGE CURRENT PATH SEPARATION CIRCUIT COMPATIBLE BATTERY PROTECTION IC FOR 1-CELL PACK
S-82G1A Series Rev.1.0_00

2. $T_a = -40^{\circ}\text{C}$ to $+85^{\circ}\text{C}^{*1}$

Table 11

($T_a = -40^{\circ}\text{C}$ to $+85^{\circ}\text{C}^{*1}$ unless otherwise specified)

Item	Symbol	Condition	Min.	Typ.	Max.	Unit	Test Circuit
Detection Voltage							
Overcharge detection voltage	V_{CU}	–	$V_{CU} - 0.045$	V_{CU}	$V_{CU} + 0.030$	V	1
Overcharge release voltage	V_{CL}	$V_{CL} \neq V_{CU}$	$V_{CL} - 0.080$	V_{CL}	$V_{CL} + 0.060$	V	1
		$V_{CL} = V_{CU}$	$V_{CL} - 0.050$	V_{CL}	$V_{CL} + 0.030$	V	1
Overdischarge detection voltage	V_{DL}	–	$V_{DL} - 0.080$	V_{DL}	$V_{DL} + 0.060$	V	2
Overdischarge release voltage	V_{DU}	$V_{DL} \neq V_{DU}$	$V_{DU} - 0.105$	V_{DU}	$V_{DU} + 0.085$	V	2
		$V_{DL} = V_{DU}$	$V_{DU} - 0.080$	V_{DU}	$V_{DU} + 0.060$	V	2
Discharge overcurrent detection voltage 1	V_{DIOV1}	–	$V_{DIOV1} - 0.002$	V_{DIOV1}	$V_{DIOV1} + 0.002$	V	5
Discharge overcurrent detection voltage 2	V_{DIOV2}	–	$V_{DIOV2} - 0.003$	V_{DIOV2}	$V_{DIOV2} + 0.003$	V	2
Load short-circuiting detection voltage	V_{SHORT}	–	$V_{SHORT} - 0.005$	V_{SHORT}	$V_{SHORT} + 0.005$	V	2
Load short-circuiting detection voltage 2	V_{SHORT2}	–	$V_{DD} - 1.4$	$V_{DD} - 0.8$	$V_{DD} - 0.3$	V	2
Charge overcurrent detection voltage	V_{CIOV}	–	$V_{CIOV} - 0.003$	V_{CIOV}	$V_{CIOV} + 0.003$	V	2
Discharge overcurrent release voltage	V_{RIOV}	$V_{DD} = 3.4\text{ V}$	$V_{DD} \times 0.77$	$V_{DD} \times 0.80$	$V_{DD} \times 0.83$	V	5
0 V Battery Charge Function							
0 V battery charge starting charger voltage	V_{0CHA}	0 V battery charge function "available"	0.5	1.3	1.9	V	4
0 V battery charge inhibition battery voltage	V_{0INH}	0 V battery charge function "unavailable"	0.7	1.2	1.7	V	2
Internal Resistance							
Resistance between VDD pin and VMC pin	R_{VMCD}	$V_{DD} = 1.8\text{ V}, V_{VMC} = 0\text{ V}$	250	1250	3500	k Ω	3
Resistance between VDD pin and VMD pin	R_{VMDD}	$V_{DD} = 1.8\text{ V}, V_{VMD} = 0\text{ V}$	250	1250	3500	k Ω	3
Resistance between VMD pin and VSS pin	R_{VMDS}	$V_{DD} = 3.4\text{ V}, V_{VMD} = 1.0\text{ V}$	3.5	10	20	k Ω	3
CTL pin internal resistance	R_{CTL}	–	$R_{CTL} \times 0.25$	R_{CTL}	$R_{CTL} \times 3.0$	M Ω	3
Input Voltage							
Operation voltage between VDD pin and VSS pin	V_{DSOP1}	–	1.5	–	6.0	V	–
Operation voltage between VDD pin and VMC pin, VMD pin	V_{DSOP2}	–	1.5	–	28	V	–
CTL pin voltage "H"	V_{CTLH}	–	$V_{CTLH} - 0.4$	V_{CTLH}	$V_{CTLH} + 0.4$	V	2
CTL pin voltage "L"	V_{CTLL}	–	$V_{CTLL} - 0.4$	V_{CTLL}	$V_{CTLL} + 0.4$	V	2
Input Current							
Current consumption during operation	I_{OPE}	$V_{DD} = 3.4\text{ V}, V_{VMC} = V_{VMD} = 0\text{ V}$	–	2.0	5.0	μA	3
Current consumption during power-down	I_{PDN}	$V_{DD} = V_{VMC} = V_{VMD} = 1.5\text{ V}$	–	–	0.1	μA	3
Current consumption during overdischarge	I_{OPED}	$V_{DD} = V_{VMC} = V_{VMD} = 1.5\text{ V}$	–	–	1.0	μA	3
Output Resistance							
CO pin resistance "H"	R_{COH}	–	2.5	10	30	k Ω	4
CO pin resistance "L"	R_{COL}	–	2.5	10	30	k Ω	4
DO pin resistance "H"	R_{DOH}	–	2.5	10	30	k Ω	4
DO pin resistance "L"	R_{DOL}	–	0.5	2	6	k Ω	4
Delay Time							
Overcharge detection delay time	t_{CU}	–	$t_{CU} \times 0.4$	t_{CU}	$t_{CU} \times 1.6$	–	5
Overdischarge detection delay time	t_{DL}	–	$t_{DL} \times 0.4$	t_{DL}	$t_{DL} \times 1.6$	–	5
Discharge overcurrent detection delay time 1	t_{DIOV1}	–	$t_{DIOV1} \times 0.4$	t_{DIOV1}	$t_{DIOV1} \times 1.6$	–	5
Discharge overcurrent detection delay time 2	t_{DIOV2}	–	$t_{DIOV2} \times 0.4$	t_{DIOV2}	$t_{DIOV2} \times 1.6$	–	5
Load short-circuiting detection delay time	t_{SHORT}	–	$t_{SHORT} \times 0.4$	t_{SHORT}	$t_{SHORT} \times 1.6$	–	5
Charge overcurrent detection delay time	t_{CIOV}	–	$t_{CIOV} \times 0.4$	t_{CIOV}	$t_{CIOV} \times 1.6$	–	5
Charge-discharge inhibition delay time	t_{CTL}	–	$t_{CTL} \times 0.4$	t_{CTL}	$t_{CTL} \times 1.6$	–	5

*1. Since products are not screened at high and low temperature, the specification for this temperature range is guaranteed by design, not tested in production.

■ Test Circuits

When CTL pin control logic is active "H", SW1 and SW3 are turned off, SW2 and SW4 are turned on. When CTL pin control logic is active "L", SW1 and SW3 are turned on, SW2 and SW4 are turned off.

Caution Unless otherwise specified, the output voltage levels "H" and "L" at CO pin (V_{CO}) and DO pin (V_{DO}) are judged by the threshold voltage (1.0 V) of the N-channel FET. Judge the CO pin level with respect to V_{VMC} and the DO pin level with respect to V_{SS} .

1. Overcharge detection voltage, overcharge release voltage (Test circuit 1)

Overcharge detection voltage (V_{CU}) is defined as the voltage V1 at which V_{CO} goes from "H" to "L" when the voltage V1 is gradually increased after setting V1 = 3.4 V. Overcharge release voltage (V_{CL}) is defined as the voltage V1 at which V_{CO} goes from "L" to "H" when the voltage V1 is then gradually decreased. Overcharge hysteresis voltage (V_{HC}) is defined as the difference between V_{CU} and V_{CL} .

2. Overdischarge detection voltage, overdischarge release voltage (Test circuit 2)

Overdischarge detection voltage (V_{DL}) is defined as the voltage V1 at which V_{DO} goes from "H" to "L" when the voltage V1 is gradually decreased after setting V1 = 3.4 V, V2 = V5 = V6 = V7 = 0 V. Overdischarge release voltage (V_{DU}) is defined as the voltage V1 at which V_{DO} goes from "L" to "H" when setting V2 = 0.01 V, V5 = V6 = V7 = 0 V and when the voltage V1 is then gradually increased. Overdischarge hysteresis voltage (V_{HD}) is defined as the difference between V_{DU} and V_{DL} .

3. Discharge overcurrent detection voltage 1, discharge overcurrent release voltage (Test circuit 5)

Discharge overcurrent detection voltage 1 (V_{DIOV1}) is defined as the voltage V5 whose delay time for changing V_{DO} from "H" to "L" is discharge overcurrent detection delay time 1 (t_{DIOV1}) when the voltage V5 is increased after setting V1 = 3.4 V, V2 = V5 = V7 = 0 V, V6 = 1.4 V. Discharge overcurrent release voltage (V_{RIOV}) is defined as the voltage V6 at which V_{DO} goes from "L" to "H" when setting V5 = 0 V, V6 = 3.4 V and when the voltage V6 is then gradually decreased.

When the voltage V6 falls below V_{RIOV} , V_{DO} will go to "H" after 1.0 ms typ. and maintain "H" during load short-circuiting detection delay time (t_{SHORT}).

4. Discharge overcurrent detection voltage 2 (Test circuit 2)

Discharge overcurrent detection voltage 2 (V_{DIOV2}) is defined as the voltage V5 whose delay time for changing V_{DO} from "H" to "L" is discharge overcurrent detection delay time 2 (t_{DIOV2}) when the voltage V5 is increased after setting V1 = 3.4 V, V2 = V5 = V7 = 0 V, V6 = 1.4 V.

5. Load short-circuiting detection voltage (Test circuit 2)

Load short-circuiting detection voltage (V_{SHORT}) is defined as the voltage V5 whose delay time for changing V_{DO} from "H" to "L" is t_{SHORT} when the voltage V5 is increased after setting V1 = 3.4 V, V2 = V5 = V7 = 0 V, V6 = 1.4 V.

6. Load short-circuiting detection voltage 2 (Test circuit 2)

Load short-circuiting detection voltage 2 (V_{SHORT2}) is defined as the voltage V6 whose delay time for changing V_{DO} from "H" to "L" is t_{SHORT} when the voltage V6 is increased after setting V1 = 3.4 V, V2 = V5 = V6 = V7 = 0 V.

7. Charge overcurrent detection voltage
(Test circuit 2)

Charge overcurrent detection voltage (V_{CIOV}) is defined as the voltage V_2 whose delay time for changing V_{CO} from "H" to "L" is charge overcurrent detection delay time (t_{CIOV}) when the voltage V_2 is decreased after setting $V_1 = 3.4\text{ V}$, $V_2 = V_5 = V_6 = V_7 = 0\text{ V}$.

8. CTL pin voltage "H", CTL pin voltage "L"
(Test circuit 2)

8.1 CTL pin control logic active "H"

The CTL pin voltage "H" (V_{CTLH}) is defined as the voltage V_7 at which V_{CO} and V_{DO} go from "H" to "L" when the voltage V_7 is gradually increased after setting $V_1 = 3.4\text{ V}$, $V_2 = V_5 = V_7 = 0\text{ V}$, $V_6 = -0.5\text{ V}$. After that, the CTL pin voltage "L" (V_{CTLL}) is defined as the voltage V_7 at which V_{CO} and V_{DO} go from "L" to "H" after V_7 is gradually decreased.

8.2 CTL pin control logic active "L"

V_{CTLL} is defined as the voltage difference between the voltage V_7 and the voltage V_1 ($V_1 - V_7$) at which V_{CO} and V_{DO} go from "H" to "L" when the voltage V_7 is gradually increased after setting $V_1 = 3.4\text{ V}$, $V_2 = V_5 = V_6 = V_7 = 0\text{ V}$. After that, V_{CTLH} is defined as $V_1 - V_7$ at which V_{CO} and V_{DO} go from "L" to "H" after V_7 is gradually decreased.

9. Current consumption during operation
(Test circuit 3)

The current consumption during operation (I_{OPE}) is the current that flows through the VDD pin (I_{DD}) under the set conditions of $V_1 = 3.4\text{ V}$, $V_2 = V_5 = V_6 = V_7 = 0\text{ V}$. However, the current flowing through the CTL pin internal resistance is excluded.

10. Current consumption during power-down, current consumption during overdischarge
(Test circuit 3)

10.1 With power-down function

The current consumption during power-down (I_{PDN}) is I_{DD} under the set conditions of $V_1 = V_2 = V_6 = 1.5\text{ V}$, $V_5 = V_7 = 0\text{ V}$.

10.2 Without power-down function

The current consumption during overdischarge (I_{OPED}) is I_{DD} under the set conditions of $V_1 = V_2 = V_6 = 1.5\text{ V}$, $V_5 = V_7 = 0\text{ V}$.

11. Resistance between VDD pin and VMC pin
(Test circuit 3)

R_{VMCD} is the resistance between VDD pin and VMC pin under the set conditions of $V_1 = 1.8\text{ V}$, $V_2 = V_5 = V_6 = V_7 = 0\text{ V}$.

12. Resistance between VDD pin and VMD pin
(Test circuit 3)

R_{VMDD} is the resistance between VDD pin and VMD pin under the set conditions of $V_1 = 1.8\text{ V}$, $V_2 = V_5 = V_6 = V_7 = 0\text{ V}$.

13. Resistance between VMD pin and VSS pin
(Test circuit 3)

R_{VMDS} is the resistance between VMD pin and VSS pin when the voltage V_5 is decreased to 0 V after setting $V_1 = 3.4\text{ V}$, $V_2 = V_7 = 0\text{ V}$, $V_5 = V_6 = 1.0\text{ V}$.

**14. CTL pin internal resistance
(Test circuit 3)**

14.1 CTL pin control logic active "H" and CTL pin internal resistance connection "pull-up"

CTL pin internal resistance (R_{CTL}) is the resistance between CTL pin and VDD pin under the set conditions of $V1 = 3.4\text{ V}$, $V2 = V5 = V6 = V7 = 0\text{ V}$.

14.2 CTL pin control logic active "H" and CTL pin internal resistance connection "pull-down"

R_{CTL} is the resistance between CTL pin and VSS pin under the set conditions of $V1 = V7 = 3.4\text{ V}$, $V2 = V5 = V6 = 0\text{ V}$.

14.3 CTL pin control logic active "L" and CTL pin internal resistance connection "pull-up"

R_{CTL} is the resistance between CTL pin and VDD pin under the set conditions of $V1 = V7 = 3.4\text{ V}$, $V2 = V5 = V6 = 0\text{ V}$.

14.4 CTL pin control logic active "L" and CTL pin internal resistance connection "pull-down"

R_{CTL} is the resistance between CTL pin and VSS pin under the set conditions of $V1 = 3.4\text{ V}$, $V2 = V5 = V6 = V7 = 0\text{ V}$.

**15. CO pin resistance "H"
(Test circuit 4)**

The CO pin resistance "H" (R_{COH}) is the resistance between VDD pin and CO pin under the set conditions of $V1 = 3.4\text{ V}$, $V2 = V5 = 0\text{ V}$, $V3 = 3.0\text{ V}$.

**16. CO pin resistance "L"
(Test circuit 4)**

The CO pin resistance "L" (R_{COL}) is the resistance between VMC pin and CO pin under the set conditions of $V1 = 4.7\text{ V}$, $V2 = V5 = 0\text{ V}$, $V3 = 0.4\text{ V}$.

**17. DO pin resistance "H"
(Test circuit 4)**

The DO pin resistance "H" (R_{DOH}) is the resistance between VDD pin and DO pin under the set conditions of $V1 = 3.4\text{ V}$, $V2 = V5 = 0\text{ V}$, $V4 = 3.0\text{ V}$.

**18. DO pin resistance "L"
(Test circuit 4)**

The DO pin resistance "L" (R_{DOL}) is the resistance between VSS pin and DO pin under the set conditions of $V1 = 1.8\text{ V}$, $V2 = V5 = 0\text{ V}$, $V4 = 0.4\text{ V}$.

**19. Overcharge detection delay time
(Test circuit 5)**

After setting $V1 = 3.4\text{ V}$, $V2 = V5 = V6 = V7 = 0\text{ V}$, the voltage $V1$ is increased. The time interval from when the voltage $V1$ exceeds V_{CU} until V_{CO} goes to "L" is the overcharge detection delay time (t_{CU}).

**20. Overdischarge detection delay time
(Test circuit 5)**

After setting $V1 = 3.4\text{ V}$, $V2 = V5 = V6 = V7 = 0\text{ V}$, the voltage $V1$ is decreased. The time interval from when the voltage $V1$ falls below V_{DL} until V_{DO} goes to "L" is the overdischarge detection delay time (t_{DL}).

21. Discharge overcurrent detection delay time 1
(Test circuit 5)

After setting $V1 = 3.4\text{ V}$, $V2 = V5 = V7 = 0\text{ V}$, $V6 = 1.4\text{ V}$, the voltage $V5$ is increased. The time interval from when the voltage $V5$ exceeds V_{DIOV1} until V_{DO} goes to "L" is the discharge overcurrent detection delay time 1 (t_{DIOV1}).

22. Discharge overcurrent detection delay time 2
(Test circuit 5)

After setting $V1 = 3.4\text{ V}$, $V2 = V5 = V7 = 0\text{ V}$, $V6 = 1.4\text{ V}$, the voltage $V5$ is increased. The time interval from when the voltage $V5$ exceeds V_{DIOV2} until V_{DO} goes to "L" is the discharge overcurrent detection delay time 2 (t_{DIOV2}).

23. Load short-circuiting detection delay time
(Test circuit 5)

After setting $V1 = 3.4\text{ V}$, $V2 = V5 = V7 = 0\text{ V}$, $V6 = 1.4\text{ V}$, the voltage $V5$ is increased. The time interval from when the voltage $V5$ exceeds V_{SHORT} until V_{DO} goes to "L" is the load short-circuiting detection delay time (t_{SHORT}).

24. Charge overcurrent detection delay time
(Test circuit 5)

After setting $V1 = 3.4\text{ V}$, $V2 = V5 = V6 = V7 = 0\text{ V}$, the voltage $V2$ is decreased. The time interval from when the voltage $V2$ falls below V_{CIOV} until V_{CO} goes to "L" is the charge overcurrent detection delay time (t_{CIOV}).

25. Charge-discharge inhibition delay time
(Test circuit 5)

25. 1 CTL pin control logic active "H"

After setting $V1 = 3.4\text{ V}$, $V2 = V5 = V7 = 0\text{ V}$, $V6 = -0.5\text{ V}$, the voltage $V7$ is increased. The time interval from when the voltage $V7$ exceeds V_{CTLH} until V_{CO} and V_{DO} go to "L" is the charge-discharge inhibition delay time (t_{CTL}).

25. 2 CTL pin control logic active "L"

After setting $V1 = 3.4\text{ V}$, $V2 = V5 = V6 = V7 = 0\text{ V}$, the voltage $V7$ is increased. The time interval from when the voltage $V1 - V7$ falls below V_{CTLL} until V_{CO} and V_{DO} go to "L" is t_{CTL} .

26. 0 V battery charge starting charger voltage (0 V battery charge function "available")
(Test circuit 4)

The 0 V battery charge starting charger voltage (V_{0CHA}) is defined as the absolute value of voltage $V2$ at which the current flowing through the CO pin (I_{CO}) exceeds $1.0\text{ }\mu\text{A}$ when the voltage $V2$ is gradually decreased after setting $V1 = V5 = 0\text{ V}$, $V2 = V3 = -0.5\text{ V}$.

27. 0 V battery charge inhibition battery voltage (0 V battery charge function "unavailable")
(Test circuit 2)

The 0 V battery charge inhibition battery voltage (V_{0INH}) is defined as the voltage $V1$ at which V_{CO} goes to "L" ($V_{CO} = V_{VM}$) when the voltage $V1$ is gradually decreased after setting $V1 = 1.8\text{ V}$, $V2 = -2.0\text{ V}$, $V5 = V6 = V7 = 0\text{ V}$.

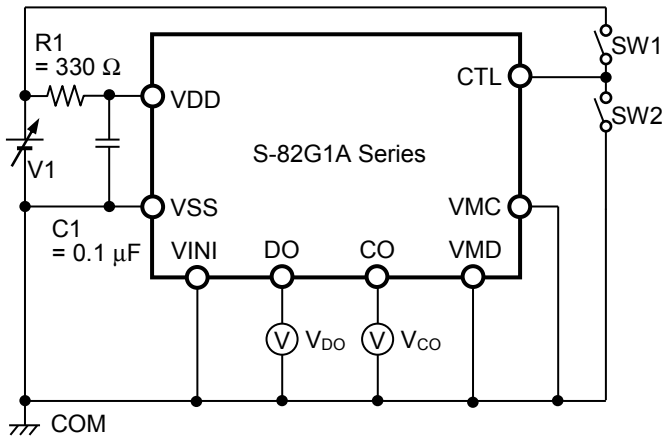

Figure 3 Test Circuit 1

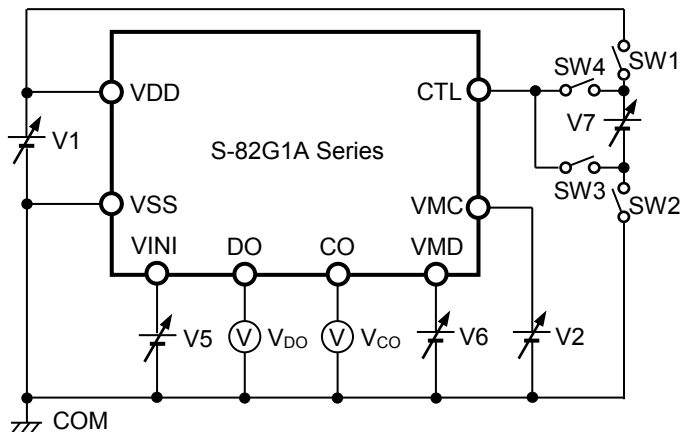

Figure 4 Test Circuit 2

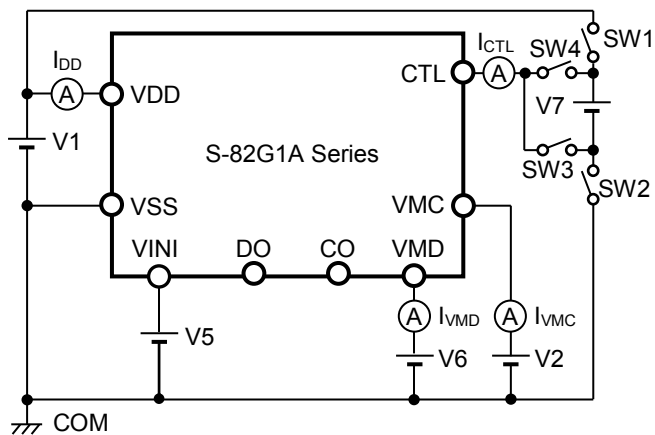

Figure 5 Test Circuit 3

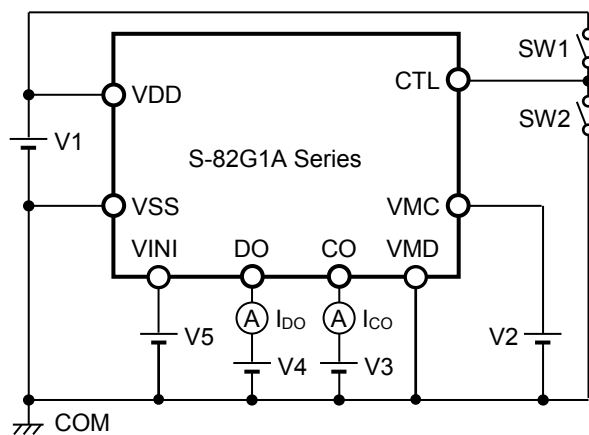

Figure 6 Test Circuit 4

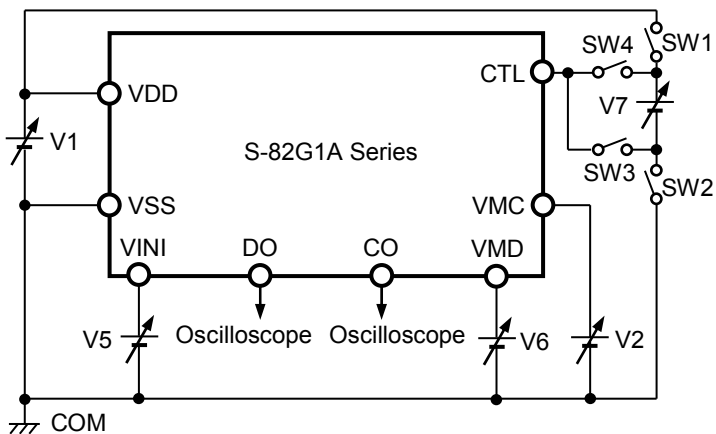

Figure 7 Test Circuit 5

■ Operation

Remark Refer to "■ Battery Protection IC Connection Example".

1. Normal status

The S-82G1A Series monitors the voltage of the battery connected between VDD pin and VSS pin, the voltage between VINI pin and VSS pin, the voltage between VMC pin and VSS pin and the voltage between CTL pin and VSS pin to control charging and discharging.

1.1 CTL pin control logic active "H"

When the battery voltage is in the range from overdischarge detection voltage (V_{DL}) to overcharge detection voltage (V_{CU}), the VINI pin voltage is equal to or lower than the discharge overcurrent detection voltage 1 (V_{DIOV1}), the VMC pin voltage is equal to or higher than the charge overcurrent detection voltage (V_{CIOV}), and the CTL pin voltage is equal to or lower than the CTL pin voltage "L" (V_{CTLL}), the S-82G1A Series turns both the charge and discharge control FETs on. This condition is called the normal status, and in this condition charging and discharging can be carried out freely.

The resistance between VDD pin and VMC pin (R_{VMCD}), the resistance between VDD pin and VMD pin (R_{VMDD}), and the resistance between VMD pin and VSS pin (R_{VMDS}) are not connected in the normal status.

1.2 CTL pin control logic active "L"

When the battery voltage is in the range from V_{DL} to V_{CU} , the VINI pin voltage is equal to or lower than V_{DIOV1} , the VMC pin voltage is equal to or higher than the charge overcurrent detection voltage (V_{CIOV}), and the CTL pin voltage is equal to or higher than CTL pin voltage "H" (V_{CTLH}), the S-82G1A Series turns both the charge and discharge control FETs on. This condition is called the normal status, and in this condition charging and discharging can be carried out freely.

R_{VMCD} , R_{VMDD} and R_{VMDS} are not connected in the normal status.

2. Overcharge status

2.1 $V_{CL} \neq V_{CU}$ (Product in which overcharge release voltage differs from overcharge detection voltage)

When the battery voltage becomes higher than V_{CU} during charging in the normal status and the condition continues for the overcharge detection delay time (t_{CU}) or longer, the S-82G1A Series turns the charge control FET off to stop charging. This condition is called the overcharge status.

The overcharge status is released in the following two cases.

- (1) In the case that the VMC pin voltage is lower than 0.35 V typ., the S-82G1A Series releases the overcharge status when the battery voltage falls below overcharge release voltage (V_{CL}).
- (2) In the case that the VMC pin voltage is equal to or higher than 0.35 V typ., the S-82G1A Series releases the overcharge status when the battery voltage falls below V_{CU} .

Even if the battery voltage exceeds V_{CU} , discharge overcurrent detection and load short-circuiting detection will function.

Caution If the battery is charged to a voltage higher than V_{CU} and the battery voltage does not fall below V_{CU} even when a load is erroneously connected to the CHA- pin, the discharge current will continue to flow until the battery voltage falls below V_{CU} .

2.2 $V_{CL} = V_{CU}$ (Product in which overcharge release voltage is the same as overcharge detection voltage)

When the battery voltage becomes higher than V_{CU} during charging in the normal status and the condition continues for t_{CU} or longer, the S-82G1A Series turns the charge control FET off to stop charging. This condition is called the overcharge status.

In the case that the VMC pin voltage is equal to or higher than 0 V typ. and the battery voltage falls below V_{CU} , the S-82G1A Series releases the overcharge status.

Even if the battery voltage exceeds the V_{CU} , discharge overcurrent detection and load short-circuiting detection will function.

Caution 1. If the battery is charged to a voltage higher than V_{CU} and the battery voltage does not fall below V_{CU} even when a load is erroneously connected to the CHA- pin, the discharge current will continue to flow until the battery voltage falls below V_{CU} .

2. When a charger is connected after overcharge detection, the overcharge status is not released even if the battery voltage is below V_{CL} . The overcharge status is released when the VMC pin voltage goes over 0 V typ. by removing the charger.

3. Overdischarge status

When the battery voltage falls below V_{DL} during discharging in the normal status and the condition continues for the overdischarge detection delay time (t_{DL}) or longer, the S-82G1A Series turns the discharge control FET off to stop discharging. This condition is called the overdischarge status.

Under the overdischarge status, the VDD pin and VMC pin are shorted by R_{VMCD} , and the VDD pin and VMD pin are shorted by R_{VMDD} in the S-82G1A Series. The VMC pin and VMD pin voltages are pulled up by R_{VMCD} and R_{VMDD} respectively.

When connecting a charger in the overdischarge status, the battery voltage reaches V_{DL} or higher and the S-82G1A Series releases the overdischarge status if the VMC pin voltage falls below 0 V typ.

The battery voltage reaches the overdischarge release voltage (V_{DU}) or higher and the S-82G1A Series releases the overdischarge status if the VMC pin voltage does not fall below 0 V typ.

R_{VMDS} is not connected in the overdischarge status.

3.1 With power-down function

Under the overdischarge status, when voltage difference between VDD pin and VMC pin is 0.8 V typ. or lower, the power-down function works and the current consumption is reduced to the current consumption during power-down (I_{PDN}). By connecting a battery charger, the power-down function is released when the VMC pin voltage is 0.7 V typ. or lower.

- When a battery is not connected to a charger and the VMC pin voltage ≥ 0.7 V typ., the S-82G1A Series maintains the overdischarge status even when the battery voltage reaches V_{DU} or higher.
- When a battery is connected to a charger and 0.7 V typ. > the VMC pin voltage > 0 V typ., the battery voltage reaches V_{DU} or higher and the S-82G1A Series releases the overdischarge status.
- When a battery is connected to a charger and 0 V typ. \geq the VMC pin voltage, the battery voltage reaches V_{DL} or higher and the S-82G1A Series releases the overdischarge status.

3.2 Without power-down function

Under the overdischarge status, the power-down function does not work even when voltage difference between VDD pin and VMC pin is 0.8 V typ. or lower.

- When a battery is not connected to a charger and the VMC pin voltage ≥ 0.7 V typ., the battery voltage reaches V_{DU} or higher and the S-82G1A Series releases the overdischarge status.
- When a battery is connected to a charger and 0.7 V typ. > the VMC pin voltage > 0 V typ., the battery voltage reaches V_{DU} or higher and the S-82G1A Series releases the overdischarge status.
- When a battery is connected to a charger and 0 V typ. \geq the VMC pin voltage, the battery voltage reaches V_{DL} or higher and the S-82G1A Series releases the overdischarge status.

4. Discharge overcurrent status (Discharge overcurrent 1, discharge overcurrent 2, load short-circuiting, load short-circuiting 2)

4.1 Discharge overcurrent 1, discharge overcurrent 2, load short-circuiting

When a battery in the normal status or the overcharge status is in the status where the VINI pin voltage is equal to or higher than V_{DIOV1} because the discharge current is equal to or higher than the specified value and the status lasts for the discharge overcurrent detection delay time 1 (t_{DIOV1}) or longer, the discharge control FET is turned off and discharging is stopped. This status is called the discharge overcurrent status.

Under the discharge overcurrent status, VMD pin and VSS pin are shorted by R_{VMDS} in the S-82G1A Series. However, the VMD pin voltage is the VDD pin voltage due to the load as long as the load is connected. When the load is disconnected, VMD pin voltage returns to the VSS pin voltage.

When the VMD pin voltage returns to V_{RIOV} or lower, the S-82G1A Series releases the discharge overcurrent status.

R_{VMDD} is not connected in the discharge overcurrent status.

4.2 Load short-circuiting 2

When a battery in the normal status or the overcharge status is in the status where a load causing discharge overcurrent is connected, and the VMD pin voltage is equal to or higher than V_{SHORT2} and the status lasts for the load short-circuiting detection delay time (t_{SHORT}) or longer, the discharge control FET is turned off and discharging is stopped. The S-82G1A Series then becomes discharge overcurrent status.

The S-82G1A Series releases the discharge overcurrent status in the same way as in "4.1 Discharge overcurrent 1, discharge overcurrent 2, load short-circuiting".

5. Charge overcurrent status

When a battery in the normal status is in the status where the VMC pin voltage is equal to or lower than V_{CIOV} because the charge current is equal to or higher than the specified value and the status lasts for the charge overcurrent detection delay time (t_{CIOV}) or longer, the charge control FET is turned off and charging is stopped. This status is called the charge overcurrent status.

The charge overcurrent status is released when the VMC pin voltage goes over 0 V typ. by removing the charger.

The charge overcurrent detection does not function in the overdischarge status.

6. Charge-discharge inhibition status

6. 1 CTL pin control logic active "H"

When the CTL pin voltage is equal to or higher than CTL pin voltage "H" (V_{CTLH}) and the status lasts for the charge-discharge inhibition delay time (t_{CTL}) or longer, the charge control FET and the discharge control FET are turned off, and charging and discharging are stopped. This status is called the charge-discharge inhibition status.

The S-82G1A Series releases charge-discharge inhibition status when the CTL pin voltage is equal to or lower than CTL pin voltage "L" ($V_{CTL L}$).

6. 2 CTL pin control logic active "L"

When the CTL pin voltage is equal to or lower than $V_{CTL L}$ and the status lasts for t_{CTL} or longer, the charge control FET and the discharge control FET are turned off, and charging and discharging are stopped. This status is called the charge-discharge inhibition status.

The S-82G1A Series releases charge-discharge inhibition status when the CTL pin voltage is equal to or higher than V_{CTLH} .

6. 3 CTL pin internal resistance connection

6. 3. 1 CTL pin internal resistance connection "pull-up"

The CTL pin is shorted to the VDD pin by the CTL pin internal resistance (R_{CTL}).

6. 3. 2 CTL pin internal resistance connection "pull-down"

The CTL pin is shorted to the VSS pin by R_{CTL} .

When the S-82G1A Series becomes overdischarge status, R_{CTL} is disconnected, and the input current and the output current to the CTL pin are cut off.

The charge-discharge control by the CTL pin does not function in the overdischarge status.

6. 4 Charge-discharge inhibition status release function by VMD pin

6. 4. 1 Charge-discharge inhibition status release function by VMD pin "available"

The S-82G1A Series releases the charge-discharge inhibition status when the VMD pin voltage rises.

6. 4. 2 Charge-discharge inhibition status release function by VMD pin "unavailable"

The S-82G1A Series does not release the charge-discharge inhibition status even when the VMD pin voltage rises.

6. 5 Transition from charge-discharge inhibition status to discharge overcurrent status

6. 5. 1 Transition from charge-discharge inhibition status to discharge overcurrent status "available"

The S-82G1A Series becomes the discharge overcurrent status when the VMD pin voltage is equal to or higher than V_{SHORT2} and the condition continues for the load short-circuiting detection delay time (t_{SHORT}) or longer.

6. 5. 2 Transition from charge-discharge inhibition status to discharge overcurrent status "unavailable"

The S-82G1A Series does not become the discharge overcurrent status and maintains the charge-discharge inhibition status even when the VMD pin voltage is equal to or higher than V_{SHORT2} and the condition continues for t_{SHORT} or longer.

7. Discharge current stop function in charge current path

When the discharge current flows to charge current path because a load is erroneously connected to a charge pin in a battery in the normal status, and the time at which the VMC pin voltage is equal to or higher than 7 mV typ. lasts for the load short-circuiting detection delay time (t_{SHORT}) or longer, the discharge current is stopped by changing the gate potential of charge control FET to the V_{SS} potential.

In this status, the VDD pin and VMC pin are shorted by R_{VMCD} in the S-82G1A Series. The VMC pin voltage is pulled up by R_{VMCD} .

The S-82G1A Series returns to the normal status once the VMC pin voltage falls below 7 mV typ. by disconnecting a load and connecting a charger.

8. 0 V battery charge function "available"

This function is used to recharge a connected battery whose voltage is 0 V due to self-discharge. When the 0 V battery charge starting charger voltage ($V_{0\text{CHA}}$) or a higher voltage is applied between the EB+ and CHA– pins by connecting a charger, the charge control FET gate is fixed to the VDD pin voltage.

When the voltage between the gate and source of the charge control FET becomes equal to or higher than the threshold voltage due to the charger voltage, the charge control FET is turned on to start charging. At this time, the discharge control FET is off and the charging current flows through the internal parasitic diode in the discharge control FET. When the battery voltage becomes equal to or higher than V_{DL} , the S-82G1A Series returns to the normal status.

Caution 1. Some battery providers do not recommend charging for a completely self-discharged lithium-ion rechargeable battery. Please ask the battery provider to determine whether to enable or inhibit the 0 V battery charge function.

2. The 0 V battery charge function has higher priority than the charge overcurrent detection function. Consequently, a product in which use of the 0 V battery charge function is enabled charges a battery forcibly and the charge overcurrent cannot be detected when the battery voltage is lower than V_{DL} .

9. 0 V battery charge function "unavailable"

This function inhibits charging when a battery that is internally short-circuited (0 V battery) is connected. When the battery voltage is the 0 V battery charge inhibition battery voltage ($V_{0\text{INH}}$) or lower, the charge control FET gate is fixed to the CHA– pin voltage to inhibit charging. When the battery voltage is $V_{0\text{INH}}$ or higher, charging can be performed.

Caution Some battery providers do not recommend charging for a completely self-discharged lithium-ion rechargeable battery. Please ask the battery provider to determine whether to enable or inhibit the 0 V battery charge function.

10. Delay circuit

The detection delay times are determined by dividing a clock of approximately 4 kHz by the counter.

Remark t_{DIOV1} , t_{DIOV2} and t_{SHORT} start when V_{DIOV1} is detected. When V_{DIOV2} or V_{SHORT} is detected over t_{DIOV2} or t_{SHORT} after the detection of V_{DIOV1} , the S-82G1A Series turns the discharge control FET off within t_{DIOV2} or t_{SHORT} of each detection.

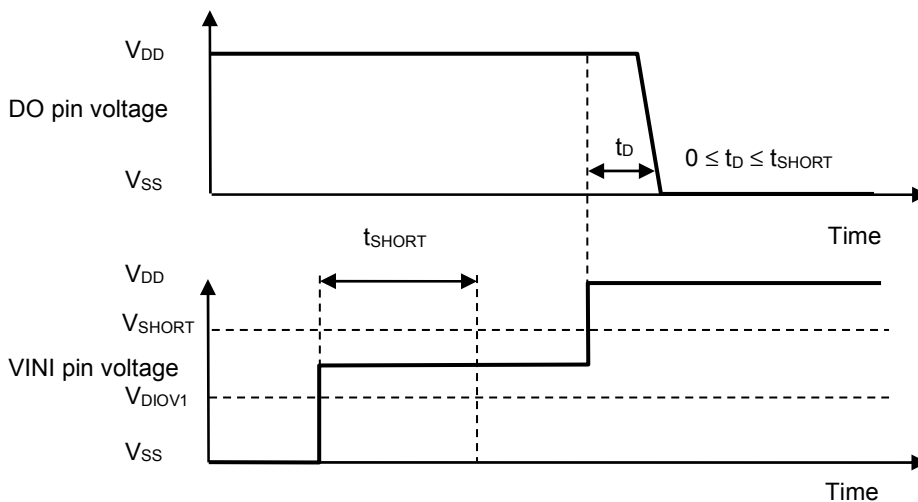
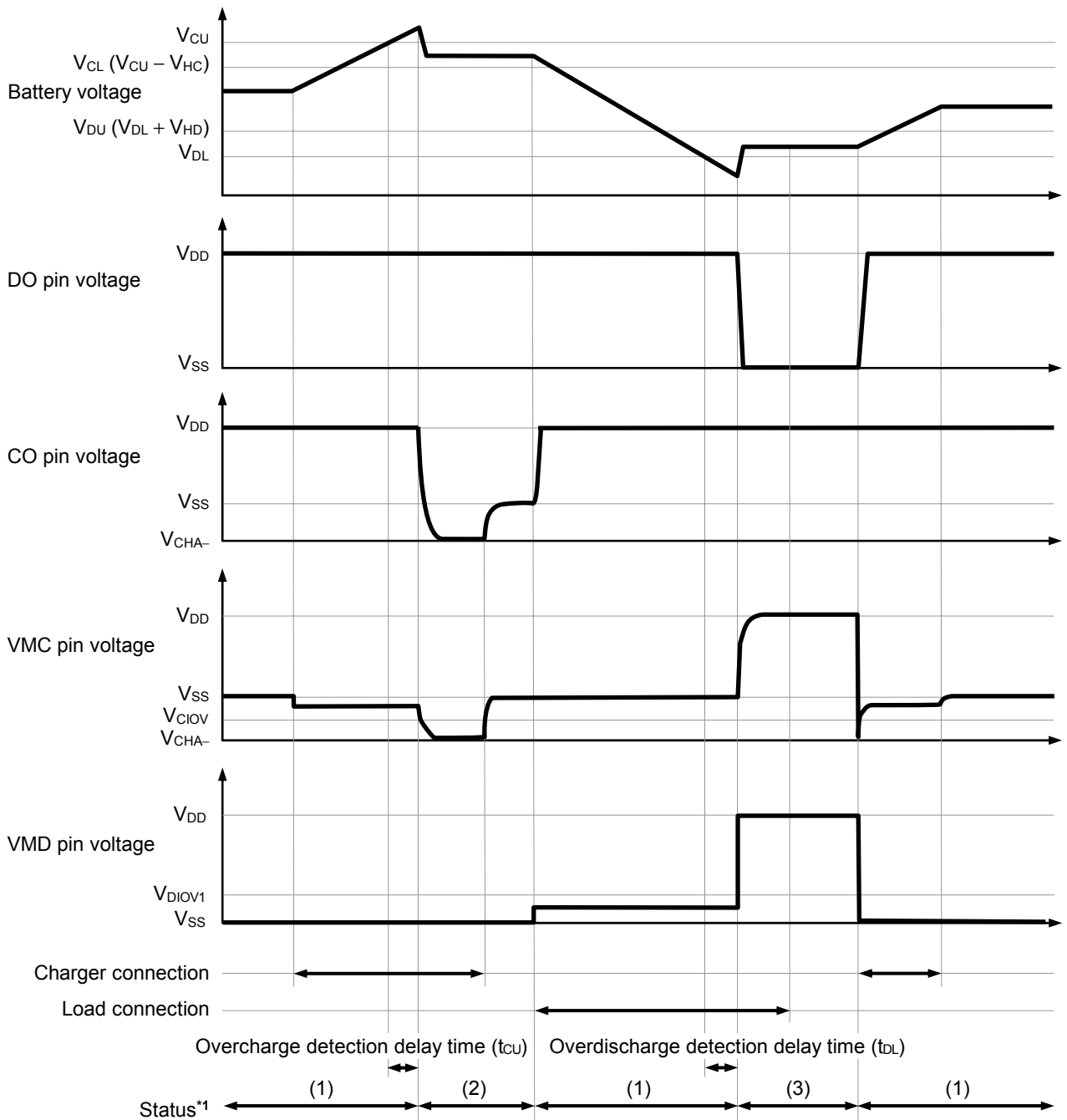

Figure 8

■ **Timing Charts**

1. Overcharge detection, overdischarge detection



- *1. (1) : Normal status
 (2) : Overcharge status
 (3) : Overdischarge status

Remark The charger is assumed to charge with a constant current.

Figure 9

2. Discharge overcurrent detection

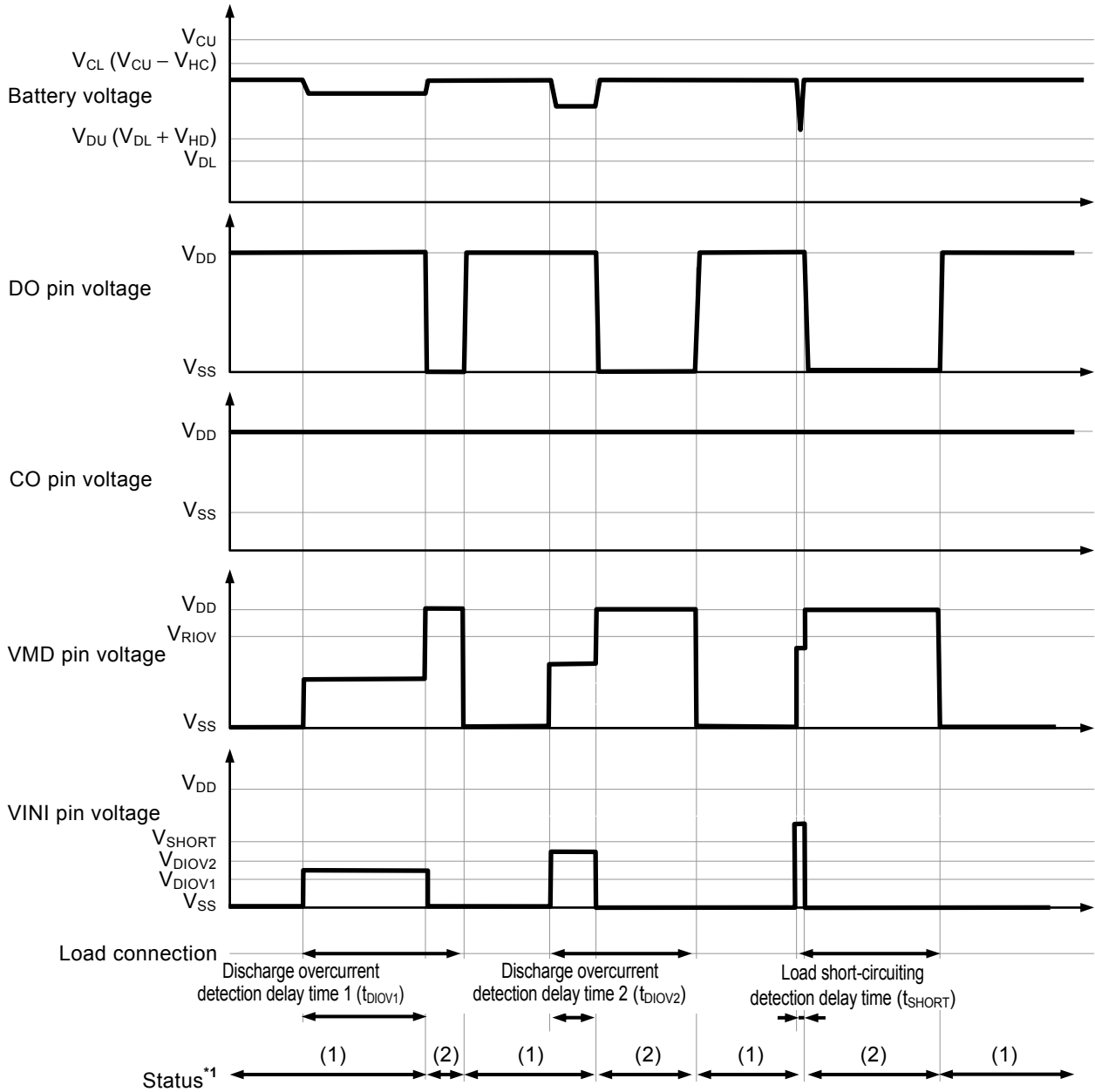

*1. (1) : Normal status
 (2) : Discharge overcurrent status

Remark The charger is assumed to charge with a constant current.

Figure 10

3. Charge overcurrent detection

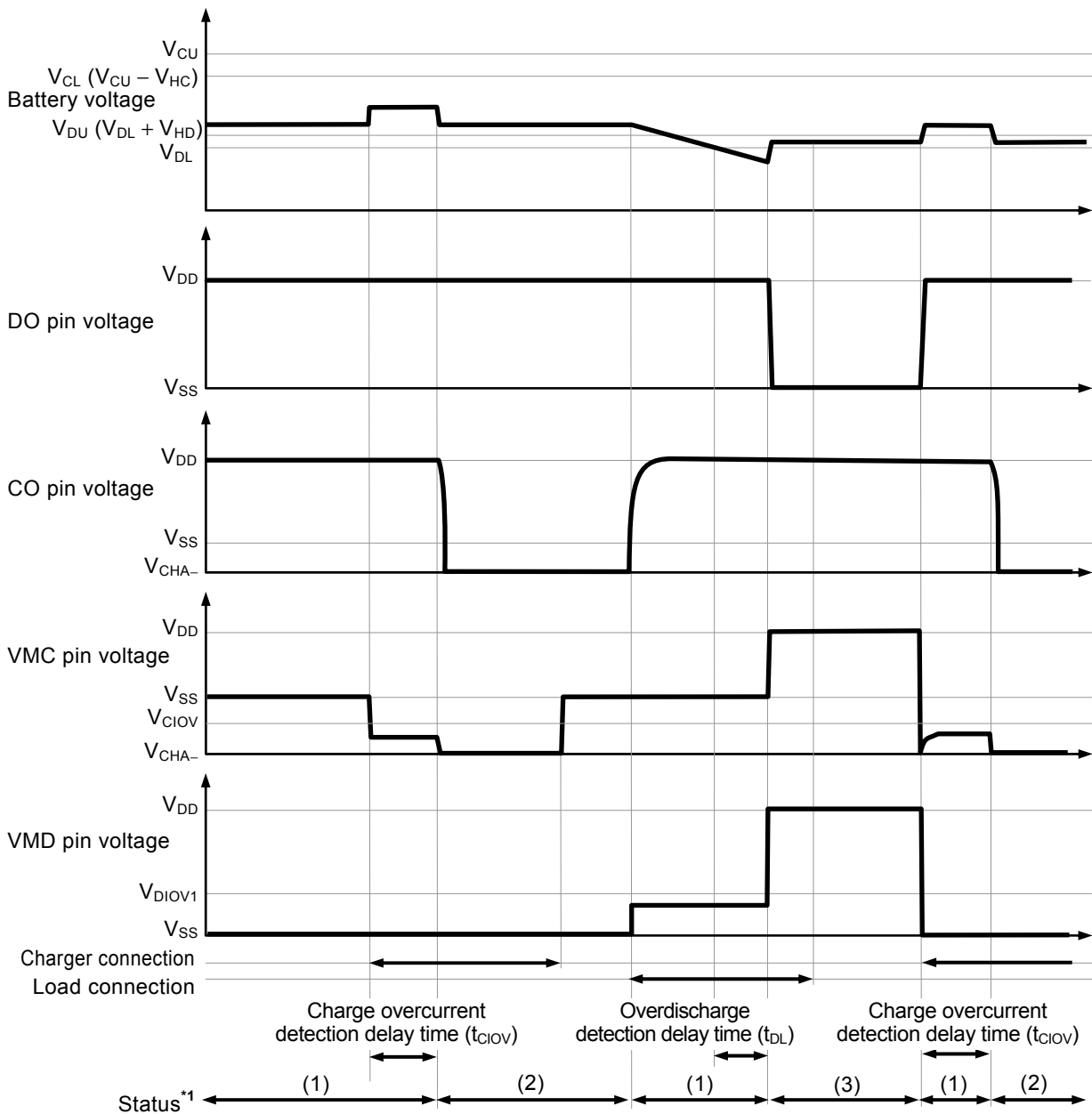

- *1. (1) : Normal status
 (2) : Charge overcurrent status
 (3) : Overdischarge status

Remark The charger is assumed to charge with a constant current.

Figure 11

4. Charge-discharge inhibition operation

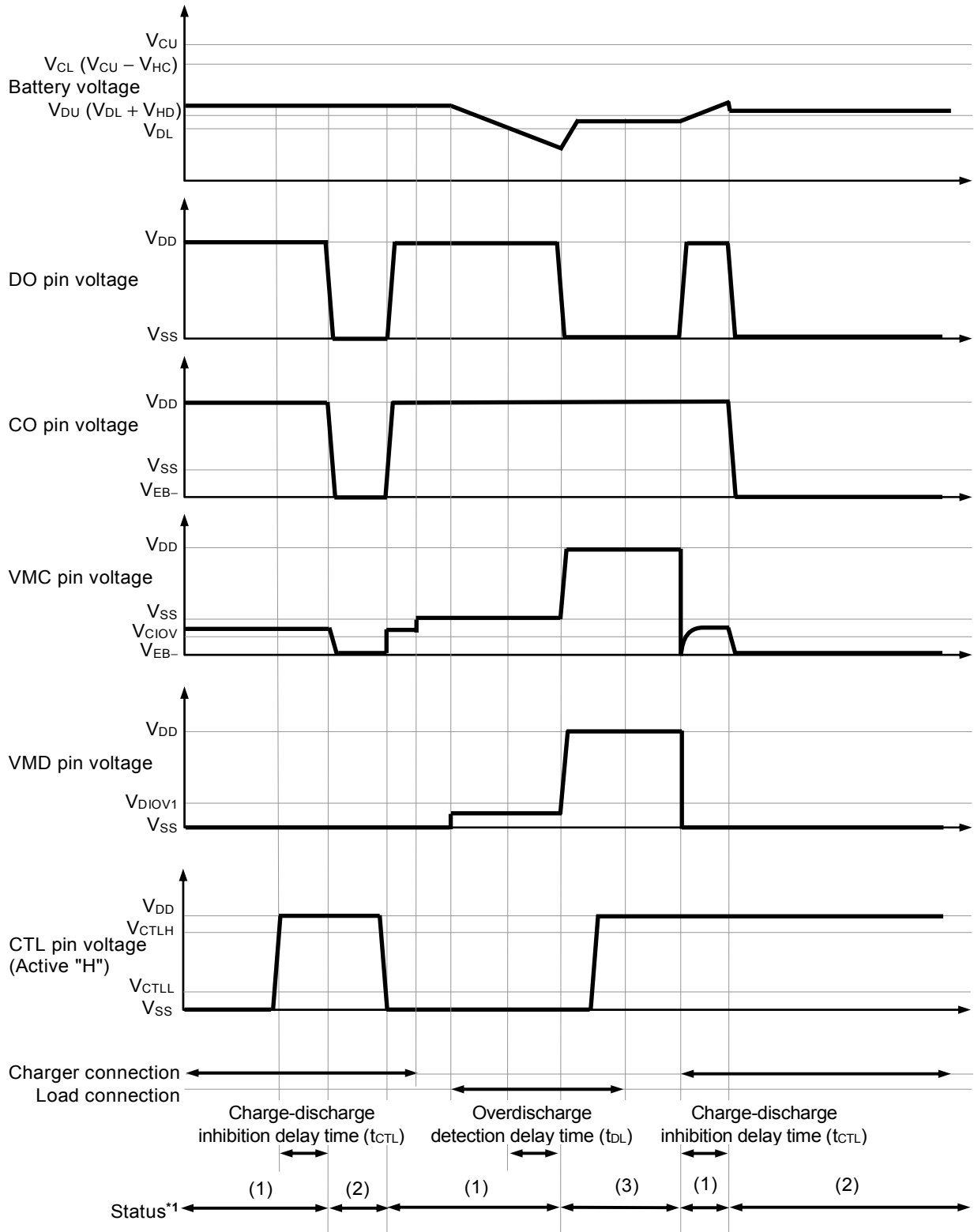

- *1. (1) : Normal status
 (2) : Charge-discharge inhibition status
 (3) : Overdischarge status

Remark The charger is assumed to charge with a constant current.

Figure 12

■ **Battery Protection IC Connection Example**

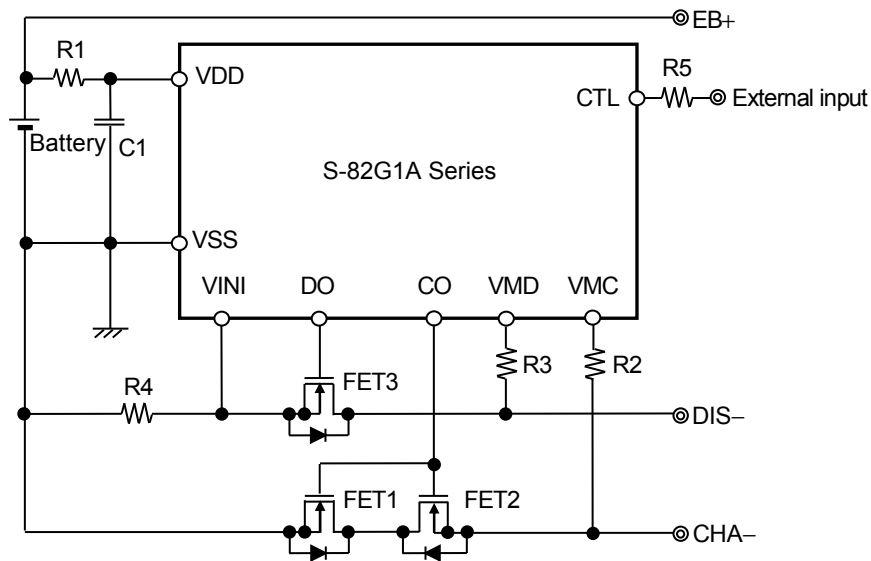

Figure 13

Table 12 Constants for External Components

Symbol	Part	Purpose	Min.	Typ.	Max.	Remark
FET1	N-channel MOS FET	Charge control	–	–	–	Threshold voltage ≤ Overdischarge detection voltage ^{*1}
FET2	N-channel MOS FET	Charge control	–	–	–	Threshold voltage ≤ Overdischarge detection voltage ^{*1}
FET3	N-channel MOS FET	Discharge control	–	–	–	Threshold voltage ≤ Overdischarge detection voltage ^{*1}
R1	Resistor	ESD protection, protection for power fluctuation	270 Ω	330 Ω	1.2 kΩ ^{*2}	–
C1	Capacitor	Protection for power fluctuation	0.068 μF	0.1 μF	2.2 μF	–
R2	Resistor	ESD protection, Protection for reverse connection of a charger	300 Ω	470 Ω	1.5 kΩ	–
R3	Resistor	ESD protection, Protection for reverse connection of a charger	300 Ω	470 Ω	1.5 kΩ	–
R4	Resistor	Discharge overcurrent detection	–	3 mΩ	–	–
R5	Resistor	CTL pin input protection	–	1 kΩ	–	–

*1. If a FET with a threshold voltage equal to or higher than the overdischarge detection voltage is used, discharging may be stopped before overdischarge is detected.

*2. Accuracy of overcharge detection voltage is guaranteed by R1 = 330 Ω. Connecting resistors with other values will worsen the accuracy.

Caution 1. The above constants may be changed without notice.

2. It has not been confirmed whether the operation is normal or not in circuits other than the above example of connection. In addition, the example of connection shown above and the constants do not guarantee proper operation. Perform thorough evaluation using the actual application to set the constants.

■ Precautions

- The application conditions for the input voltage, output voltage, and load current should not exceed the power dissipation.
- Do not apply an electrostatic discharge to this IC that exceeds the performance ratings of the built-in electrostatic protection circuit.
- ABLIC Inc., claims no responsibility for any and all disputes arising out of or in connection with any infringement by products including this IC of patents owned by a third party.

■ **Characteristics (Typical Data)**

1. Current consumption

1. 1 I_{OPE} vs. T_a

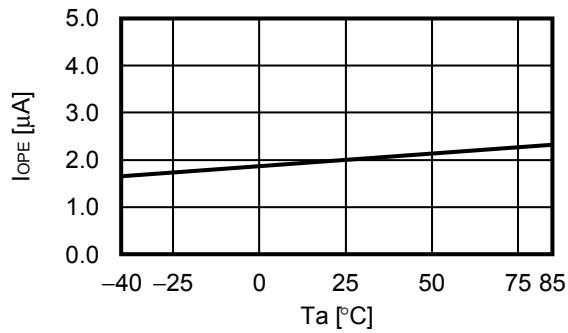

1. 2 I_{PDN} vs. T_a

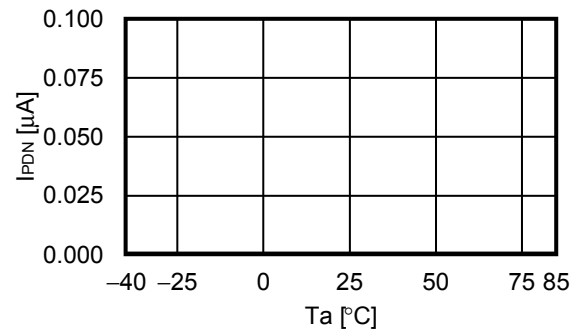

1. 3 I_{OPED} vs. T_a

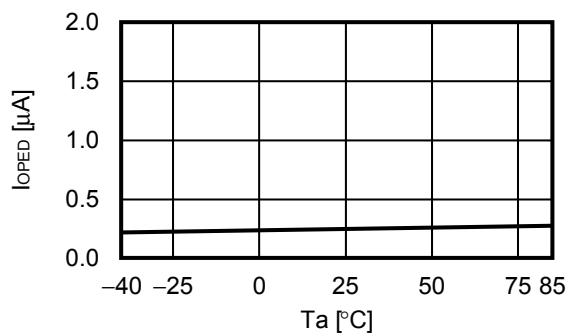

1. 4 I_{OPE} vs. V_{DD}

1. 4. 1 With power-down function

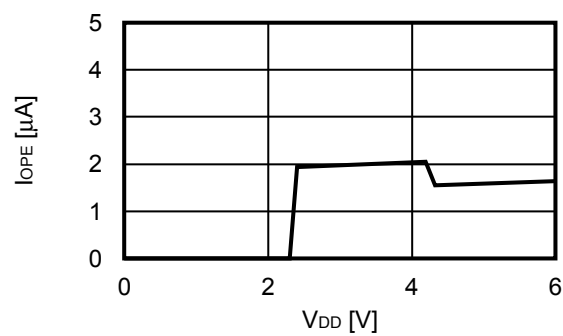

1. 4. 2 Without power-down function

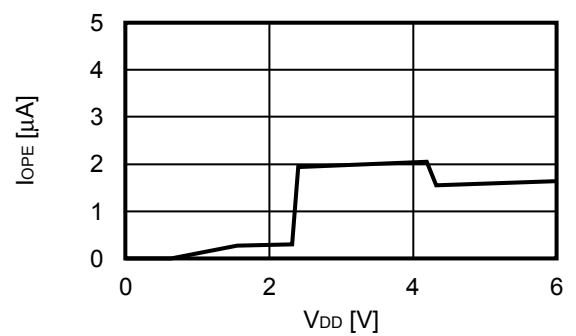

2. Detection voltage

2. 1 V_{CU} vs. T_a

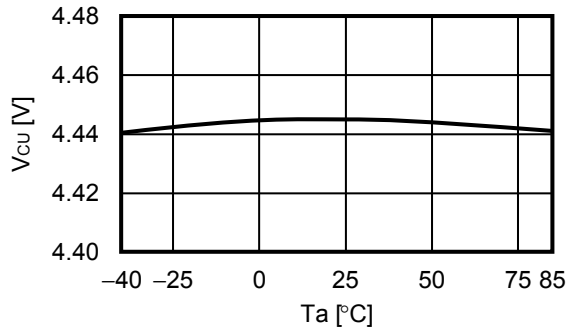

2. 2 V_{CL} vs. T_a

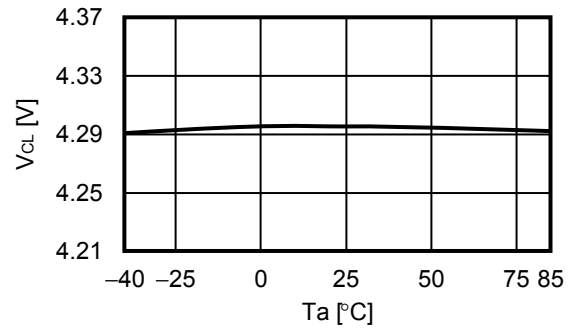

2. 3 V_{DL} vs. T_a

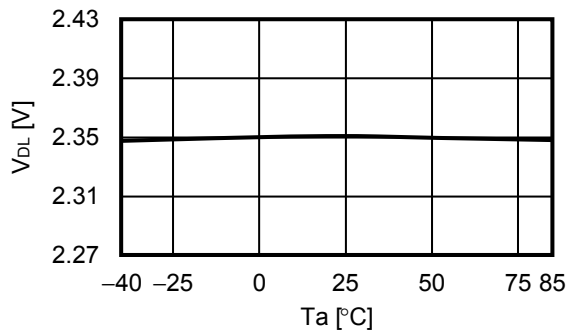

2. 4 V_{DU} vs. T_a

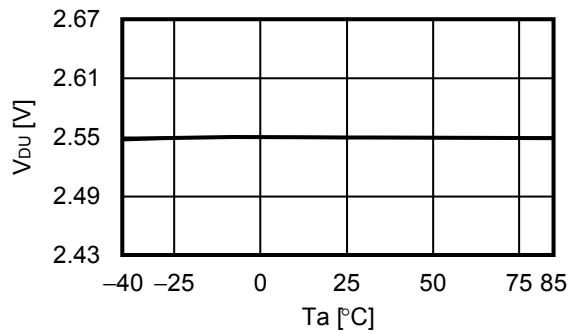

2. 5 V_{DIOV1} vs. V_{DD}

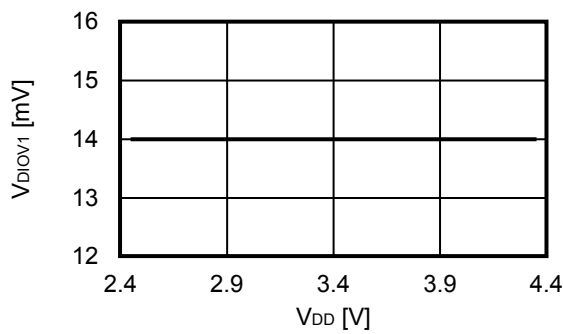

2. 6 V_{DIOV1} vs. T_a

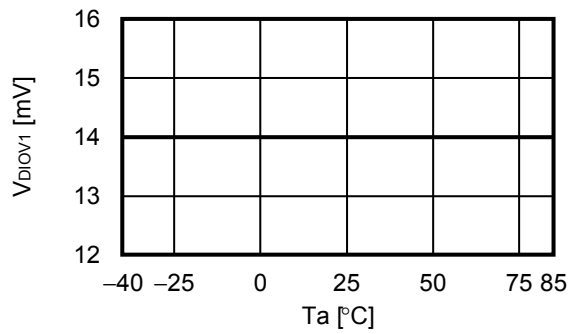

2. 7 V_{DIOV2} vs. V_{DD}

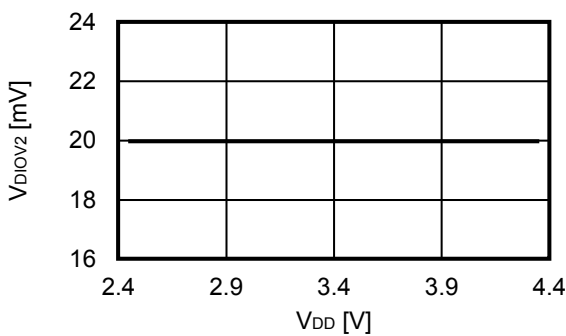

2. 8 V_{DIOV2} vs. T_a

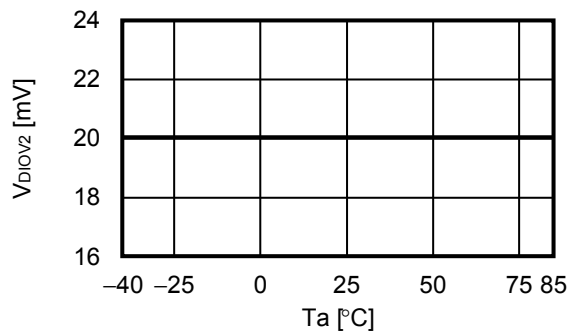

2. 9 V_{SHORT} vs. V_{DD}

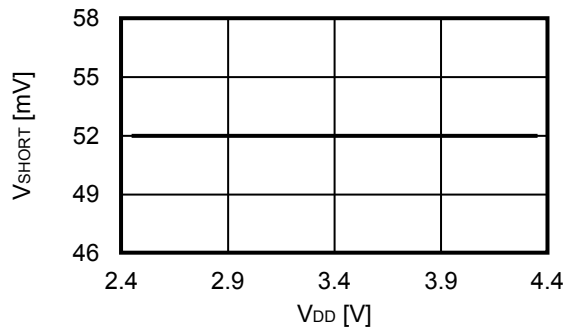

2. 10 V_{SHORT} vs. T_a

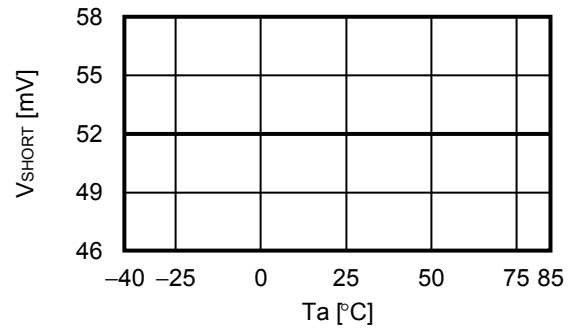

2. 11 V_{CLOV} vs. V_{DD}

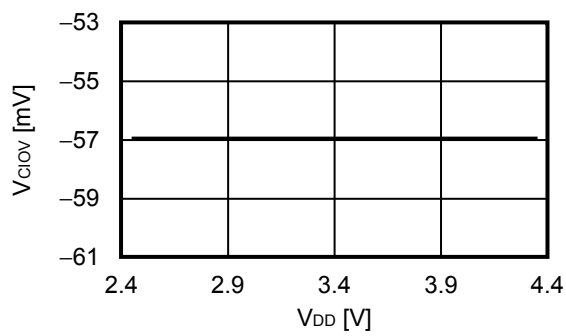

2. 12 V_{CLOV} vs. T_a

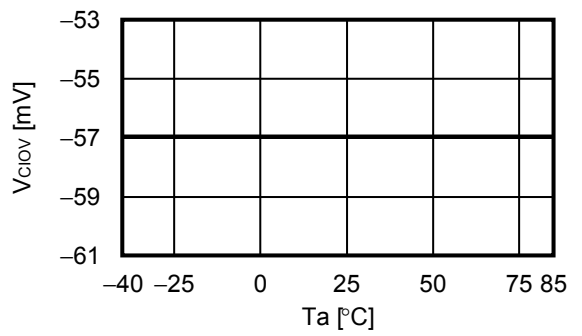

3. Delay time

3.1 t_{CU} vs. T_a

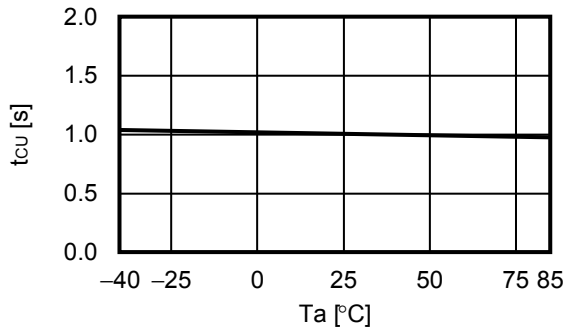

3.2 t_{DL} vs. T_a

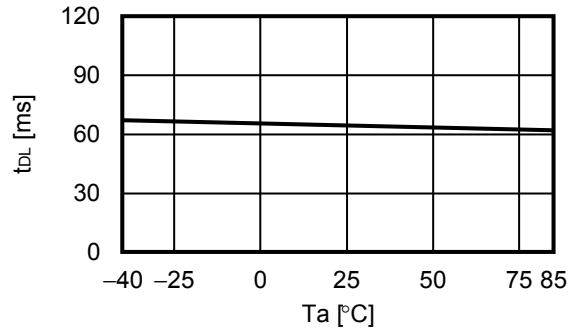

3.3 t_{DIOV1} vs. V_{DD}

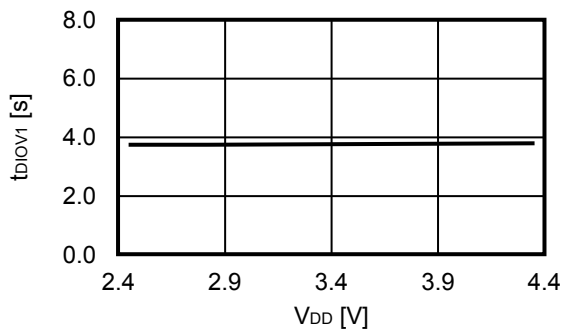

3.4 t_{DIOV1} vs. T_a

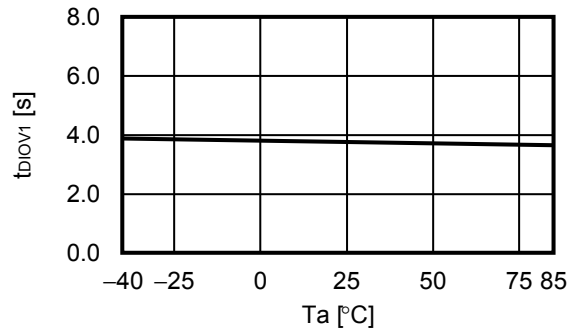

3.5 t_{DIOV2} vs. V_{DD}

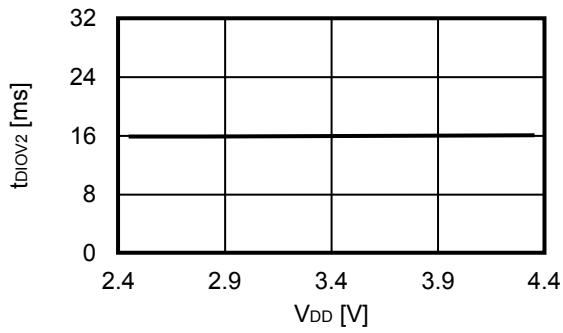

3.6 t_{DIOV2} vs. T_a

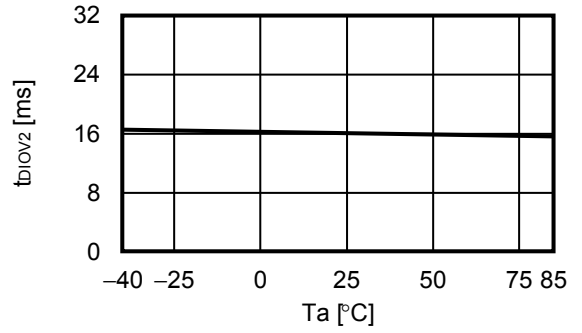

3.7 t_{SHORT} vs. V_{DD}

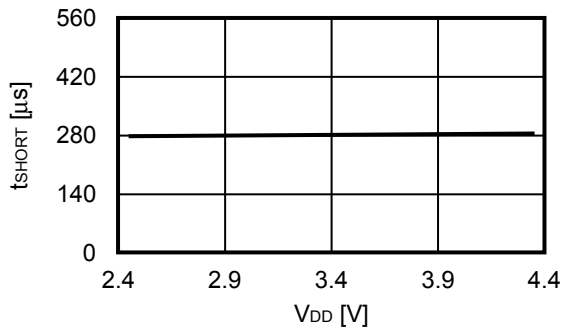

3.8 t_{SHORT} vs. T_a

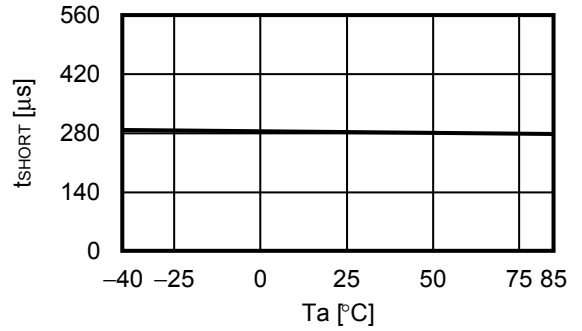

3. 9 t_{CIOV} vs. V_{DD}

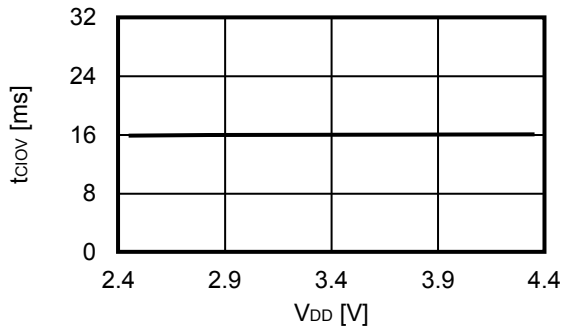

3. 10 t_{CIOV} vs. T_a

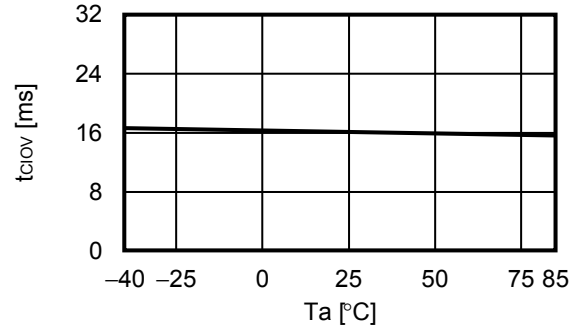

3. 11 t_{CTL} vs. V_{DD}

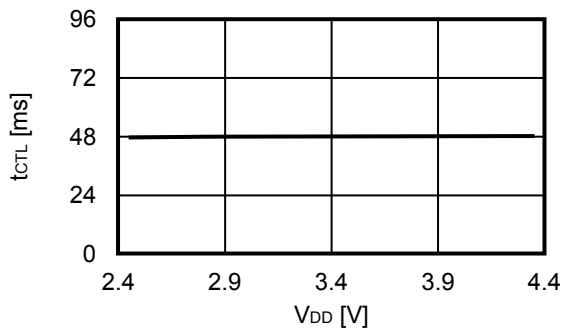

3. 12 t_{CTL} vs. T_a

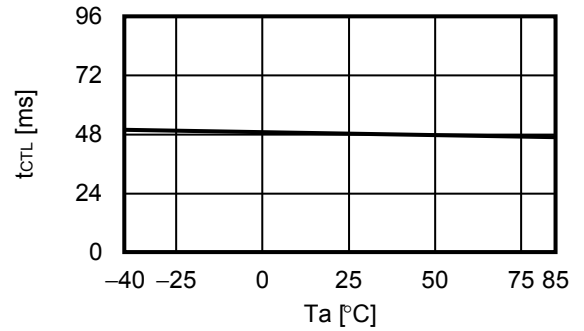

4. Output resistance

4. 1 R_{COH} vs. V_{CO}

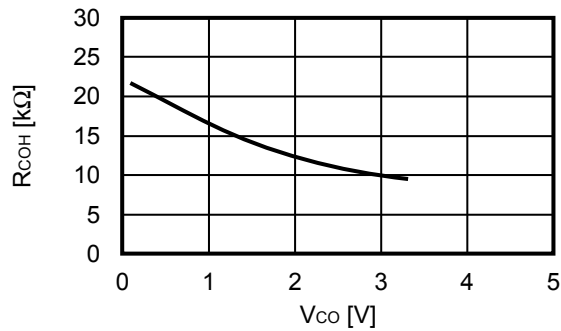

4. 2 R_{COL} vs. V_{CO}

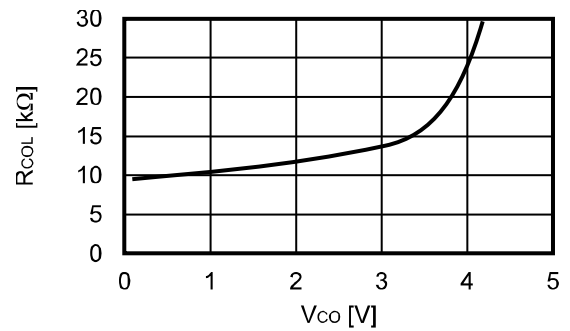

4. 3 R_{DOH} vs. V_{DO}

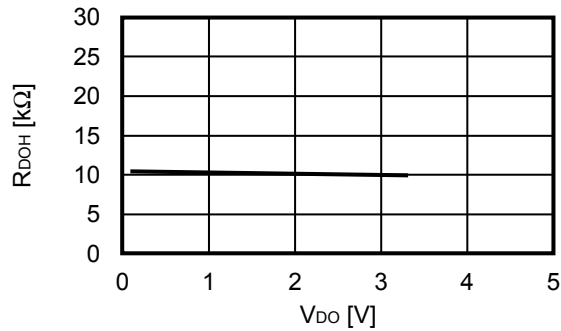

4. 4 R_{DOL} vs. V_{DO}

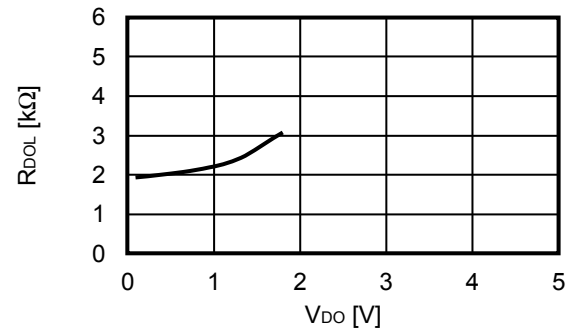

■ **Marking Specifications**

1. HSNT-8(1616)

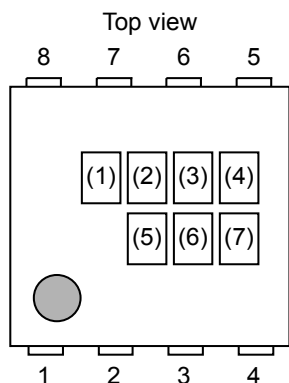

- (1): Blank
- (2) to (4): Product code (refer to **Product name vs. Product code**)
- (5) to (7): Lot number

Product name vs. Product code

Product Name	Product Code		
	(2)	(3)	(4)
S-82G1AAA-A8T2U	7	J	A

■ **Power Dissipation**

HSNT-8(1616)

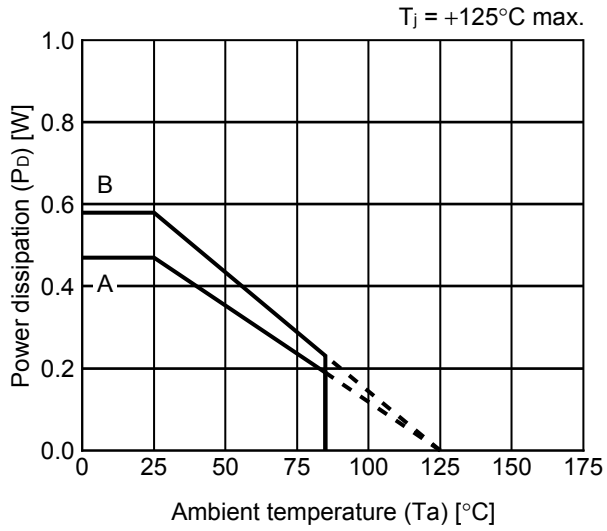

Board	Power Dissipation (P_D)
A	0.47 W
B	0.58 W
C	—
D	—
E	—

HSNT-8(1616) Test Board

 IC Mount Area

(1) Board A

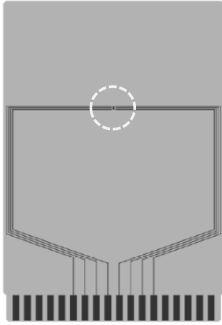

Item		Specification
Size [mm]		114.3 x 76.2 x t1.6
Material		FR-4
Number of copper foil layer		2
Copper foil layer [mm]	1	Land pattern and wiring for testing: t0.070
	2	-
	3	-
	4	74.2 x 74.2 x t0.070
Thermal via		-

(2) Board B

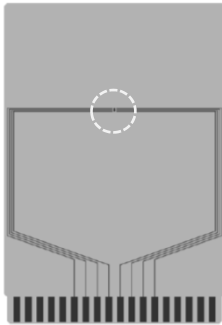

Item		Specification
Size [mm]		114.3 x 76.2 x t1.6
Material		FR-4
Number of copper foil layer		4
Copper foil layer [mm]	1	Land pattern and wiring for testing: t0.070
	2	74.2 x 74.2 x t0.035
	3	74.2 x 74.2 x t0.035
	4	74.2 x 74.2 x t0.070
Thermal via		-

No. HSNT8-B-Board-SD-1.0

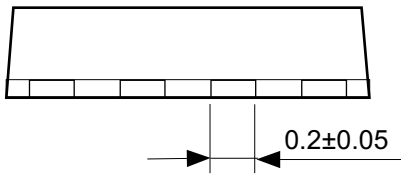
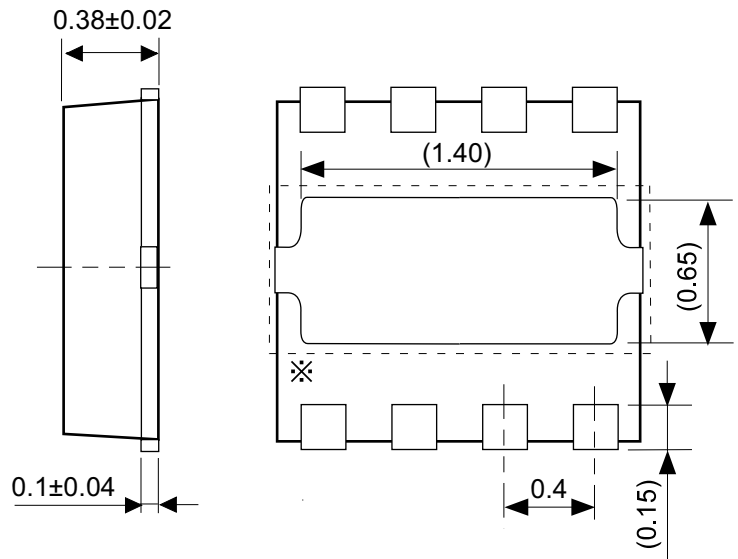
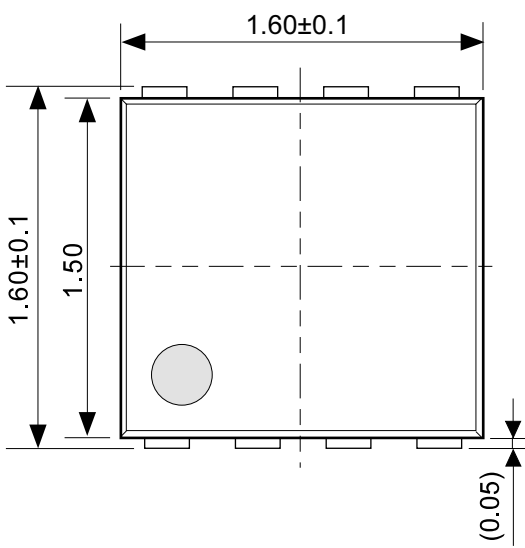

※ The heat sink of back side has different electric potential depending on the product.
 Confirm specifications of each product.
 Do not use it as the function of electrode.

No. PY008-A-P-SD-1.0

TITLE	HSNT-8-B-PKG Dimensions
No.	PY008-A-P-SD-1.0
ANGLE	
UNIT	mm
ABLIC Inc.	

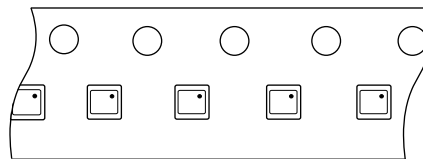
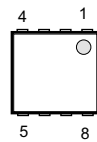
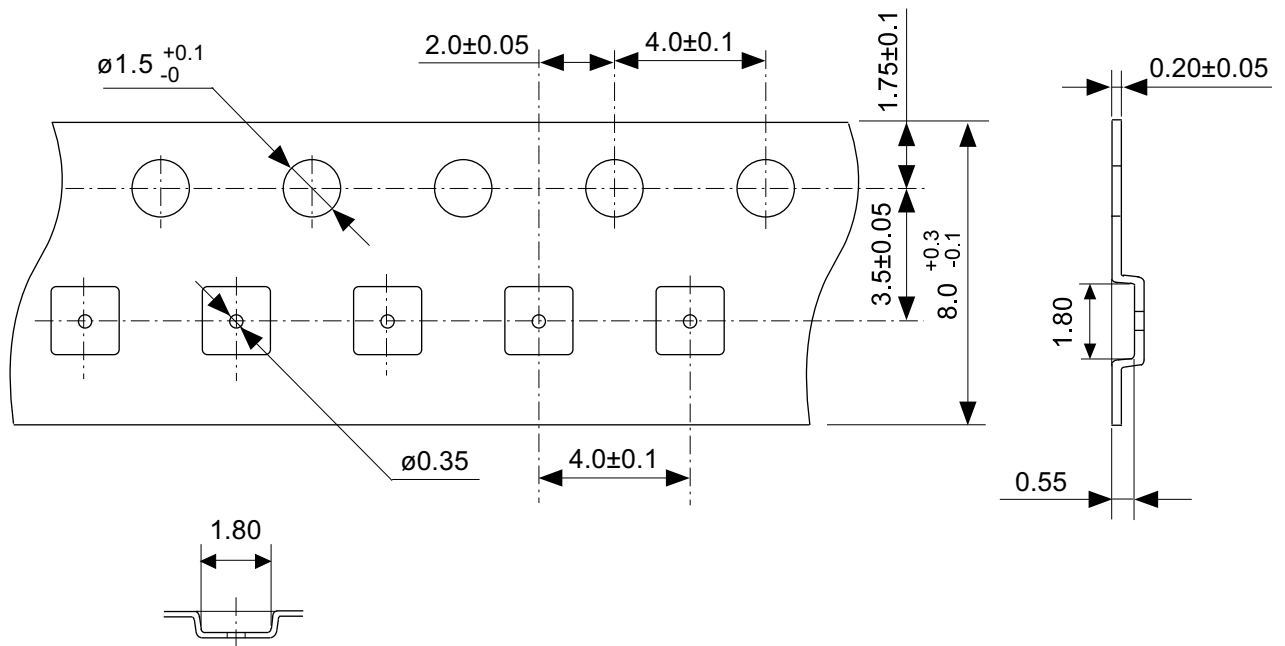

No. PY008-A-C-SD-1.0

TITLE	HSNT-8-B-Carrier Tape
No.	PY008-A-C-SD-1.0
ANGLE	
UNIT	mm
ABLIC Inc.	

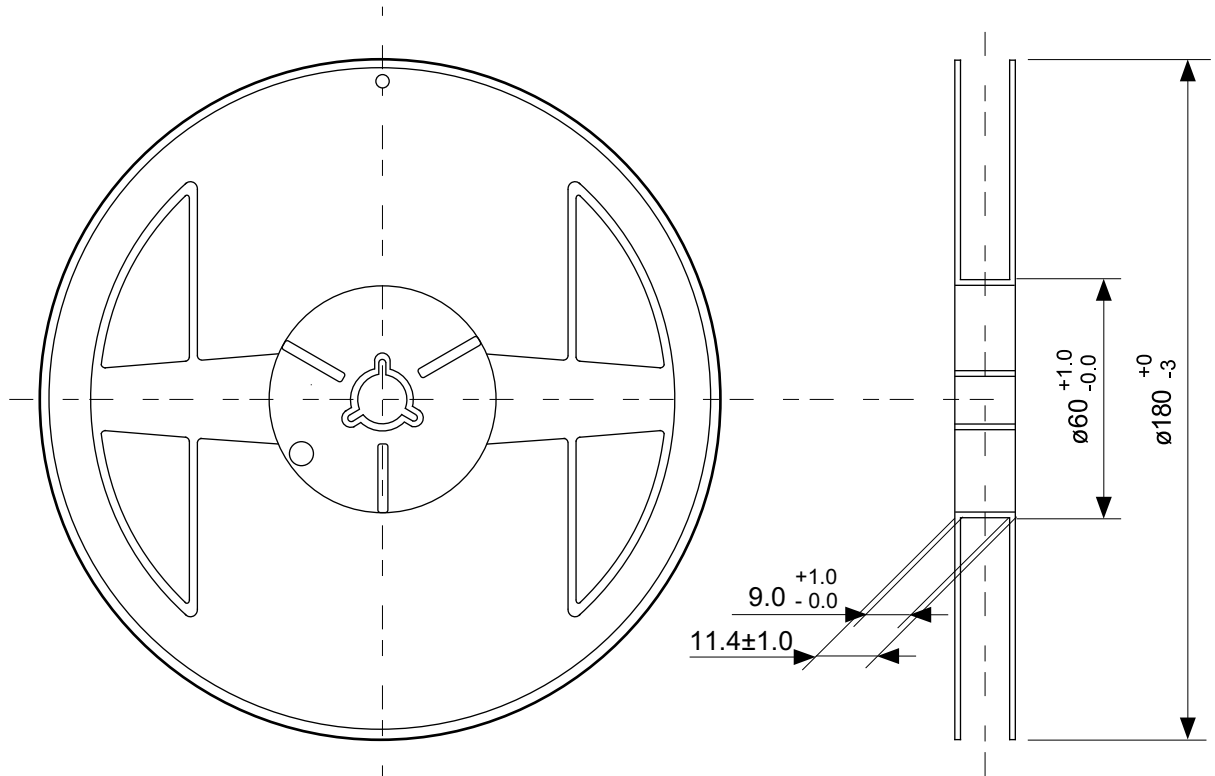

Enlarged drawing in the central part

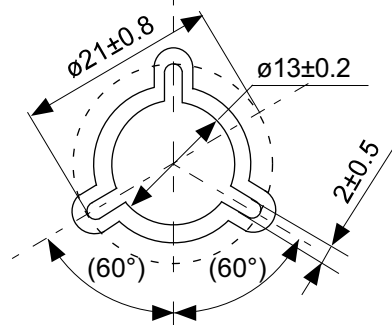

No. PY008-A-R-SD-1.0

TITLE	HSNT-8-B-Reel		
No.	PY008-A-R-SD-1.0		
ANGLE		QTY.	5,000
UNIT	mm		
ABLIC Inc.			

Land Pattern

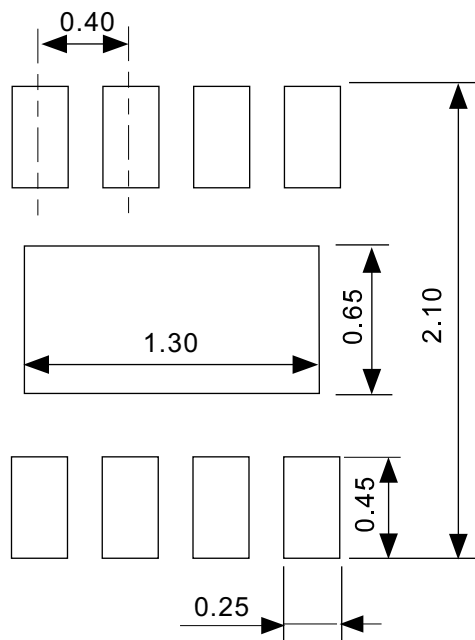

Caution It is recommended to solder the heat sink to a board in order to ensure the heat radiation.

注意 放熱性を確保する為に、PKGの裏面放熱板(ヒートシンク)を基板に半田付けする事を推奨いたします。

Metal Mask Pattern

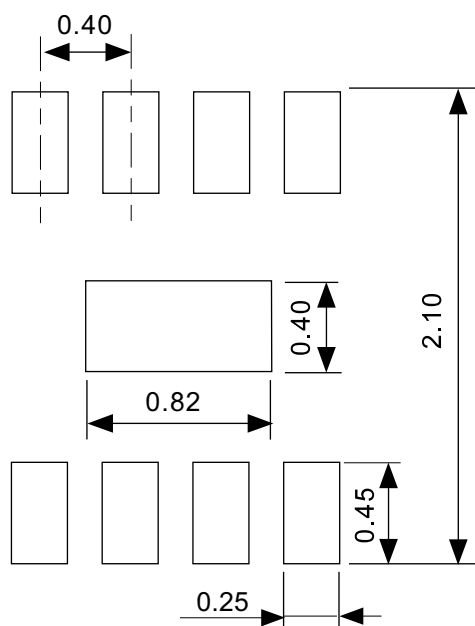

Caution ① Mask aperture ratio of the lead mounting part is 100%.
 ② Mask aperture ratio of the heat sink mounting part is 40%.
 ③ Mask thickness: t0.12 mm

注意 ①リード実装部のマスク開口率は100%です。
 ②放熱板実装のマスク開口率は40%です。
 ③マスク厚み : t0.12 mm

No. PY008-A-L-SD-1.0

TITLE	HSNT-8-B -Land Recommendation
No.	PY008-A-L-SD-1.0
ANGLE	
UNIT	mm
ABLIC Inc.	

Disclaimers (Handling Precautions)

1. All the information described herein (product data, specifications, figures, tables, programs, algorithms and application circuit examples, etc.) is current as of publishing date of this document and is subject to change without notice.
2. The circuit examples and the usages described herein are for reference only, and do not guarantee the success of any specific mass-production design.
ABLIC Inc. is not liable for any losses, damages, claims or demands caused by the reasons other than the products described herein (hereinafter "the products") or infringement of third-party intellectual property right and any other right due to the use of the information described herein.
3. ABLIC Inc. is not liable for any losses, damages, claims or demands caused by the incorrect information described herein.
4. Be careful to use the products within their ranges described herein. Pay special attention for use to the absolute maximum ratings, operation voltage range and electrical characteristics, etc.
ABLIC Inc. is not liable for any losses, damages, claims or demands caused by failures and / or accidents, etc. due to the use of the products outside their specified ranges.
5. Before using the products, confirm their applications, and the laws and regulations of the region or country where they are used and verify suitability, safety and other factors for the intended use.
6. When exporting the products, comply with the Foreign Exchange and Foreign Trade Act and all other export-related laws, and follow the required procedures.
7. The products are strictly prohibited from using, providing or exporting for the purposes of the development of weapons of mass destruction or military use. ABLIC Inc. is not liable for any losses, damages, claims or demands caused by any provision or export to the person or entity who intends to develop, manufacture, use or store nuclear, biological or chemical weapons or missiles, or use any other military purposes.
8. The products are not designed to be used as part of any device or equipment that may affect the human body, human life, or assets (such as medical equipment, disaster prevention systems, security systems, combustion control systems, infrastructure control systems, vehicle equipment, traffic systems, in-vehicle equipment, aviation equipment, aerospace equipment, and nuclear-related equipment), excluding when specified for in-vehicle use or other uses by ABLIC, Inc. Do not apply the products to the above listed devices and equipments.
ABLIC Inc. is not liable for any losses, damages, claims or demands caused by unauthorized or unspecified use of the products.
9. In general, semiconductor products may fail or malfunction with some probability. The user of the products should therefore take responsibility to give thorough consideration to safety design including redundancy, fire spread prevention measures, and malfunction prevention to prevent accidents causing injury or death, fires and social damage, etc. that may ensue from the products' failure or malfunction.
The entire system in which the products are used must be sufficiently evaluated and judged whether the products are allowed to apply for the system on customer's own responsibility.
10. The products are not designed to be radiation-proof. The necessary radiation measures should be taken in the product design by the customer depending on the intended use.
11. The products do not affect human health under normal use. However, they contain chemical substances and heavy metals and should therefore not be put in the mouth. The fracture surfaces of wafers and chips may be sharp. Be careful when handling these with the bare hands to prevent injuries, etc.
12. When disposing of the products, comply with the laws and ordinances of the country or region where they are used.
13. The information described herein contains copyright information and know-how of ABLIC Inc. The information described herein does not convey any license under any intellectual property rights or any other rights belonging to ABLIC Inc. or a third party. Reproduction or copying of the information from this document or any part of this document described herein for the purpose of disclosing it to a third-party is strictly prohibited without the express permission of ABLIC Inc.
14. For more details on the information described herein or any other questions, please contact ABLIC Inc.'s sales representative.
15. This Disclaimers have been delivered in a text using the Japanese language, which text, despite any translations into the English language and the Chinese language, shall be controlling.

2.4-2019.07